

# VL 280

## Prestazioni motori 4 poli – Servizio S1 – Protezione IP23S

*Performances motors 4 poles - Duty S1 – Protection IP23S*

	Velocità nominale <i>Nominal speed</i>	Potenza nominale <i>Nominal power</i>	Coppia nominale <i>Nominal torque</i>	Tensione nominale <i>Nominal voltage</i>	Corrente nominale <i>Nominal current</i>	Coppia massima <i>Maximum torque</i>	Velocità massima a potenza costante <i>Maximum speed at constant power</i>	Velocità meccanica massima <i>Maximum mechanical speed</i>	Inerzia rotore <i>Rotor inertia</i>	Peso <i>Weight</i>
Type	nn rpm	Pn kW	Tn Nm	Vn V	In A	Tmax Nm	np rpm	nmax rpm	J kgm <sup>2</sup>	Kg
VL 280 S	700	210	2900	400	370	4650	900	3000	3,93	1290
	840	250	2860		439	4570	1100			
	1000	310	2800		535	4480	1400			
	<b>1500</b>	<b>405</b>	<b>2680</b>		<b>685</b>	<b>4250</b>	<b>1500</b>			
VL 280 M	600	200	3500	400	366	5600	700	3000	4,70	1520
	700	245	3468		434	5540	900			
	870	309	3391		530	2424	1100			
	<b>1170</b>	<b>400</b>	<b>3270</b>		<b>688</b>	<b>5200</b>	<b>1600</b>			
VL 280 L	570	225	3780	400	410	6045	700	3000	4,70	1520
	720	280	3720		503	5950	900			
	1000	370	3600		650	5760	1300			
	<b>1500</b>	<b>525</b>	<b>3315</b>		<b>907</b>	<b>5300</b>	<b>1600</b>			

# Dimensioni di ingombro VL 280 - IP23S

## Overall dimensions VL 280 - IP 23S

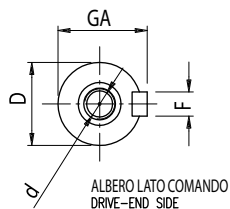
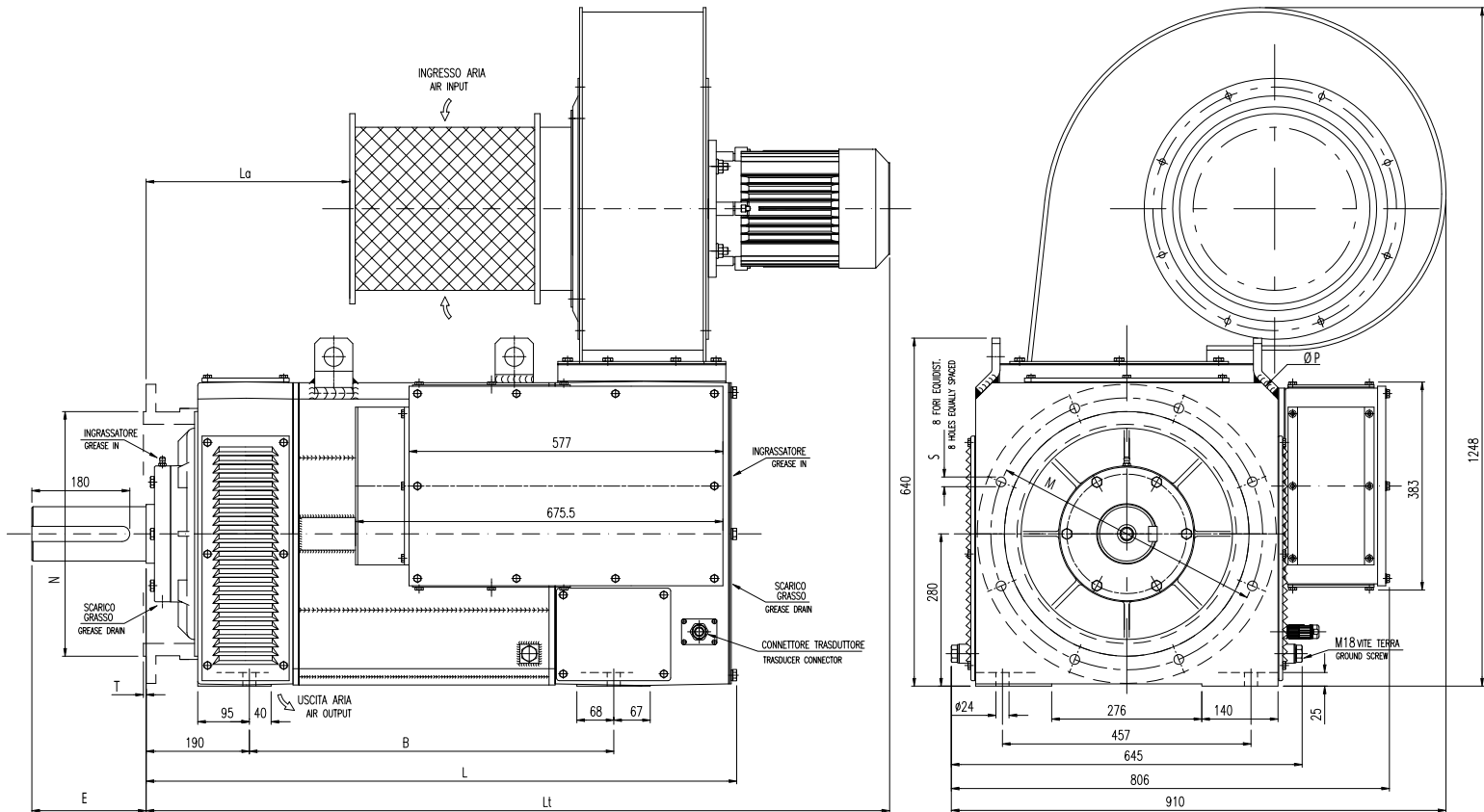

Tipo Type	Lunghezza Length				Albero Shaft					Flangia Front flange					
	B	La	L	Lt	D	E	GA	F	d	P	N	T	M	S	
VL 280	S	670	375	1086	100m6	210	106	28	M24	550	450	5	500	18	
	M	770	475	1186											1467
	L	930	635	1346											1627

Motori con freno: vedere lunghezza aggiuntiva tabella freni

Motors with brake: see additional length on the brake table