



Totally Focused. Totally Independent.

Technical Guide

---

ECP34 4 A



The world's largest  
independent producer of  
alternators 1 – 5,000kVA

## Standards

Alternators are designed and produced within an ISO 9001 environment. The entire series is manufactured according to, and complies with, the most common specifications such as CEI 2-3, IEC 34-1, EN 60034-1, VDE 0530, BS 4999-5000, NF 51.111, CAN/CSA-C22.2 No14-95-No100-95, NEMA MG 1-2011, ISO 8528-3. Other standards such as UL1446, UL 1004/4 and /B are available on request.

## Windings and Performances

All windings are 2/3rds pitch to eliminate triplen harmonics within the voltage waveform and to avoid excessive neutral currents in certain parallel operating conditions. A fully interconnected aluminium or copper damper cage is supplied on the rotor of all models (excluding the ECP3 series).

- ▶ 12 wire reconnectable:
  - 50Hz – 380V to 440V and 220/110V to 240/120V (de-rates may apply at certain voltages)
  - 60Hz – 380V to 480V and 220/110V to 240/120V (de-rates may apply at certain voltages)
- ▶ 6 wire reconnectable:
  - 50Hz – 380V to 440V and 220V to 240V (de-rates may apply at certain voltages)
  - 60Hz – 380V to 480V and 220V to 240V (de-rates may apply at certain voltages)

Winding Configurations	Standard		Special (dedicated)			
	12 wire Reconnectable	6 wire Reconnectable	380V and 600V 60Hz	690V 50/60Hz	220-240V 1ph 50Hz	220-240V 1ph 60Hz
ECP3 to ECO38	Std	Option	Option	Option	Option	Option
ECO40 to ECO46	Std	Option	Option	Option	Option (to ECO40)	Option (to ECO40)
Insulation materials	Class H	Class H	Class H	Class H	Class H	Class H
High efficiency	Std	Std	Std	Std	Std	Std
High motor starting	>300%	>300%	>300%	>300%	>300%	>300%
THD (Total Harmonic Distortion)	Typically <3.5% full load L-L	Typically <3.0% full load L-L	Typically <3.5% full load L-L	Typically <3.5% full load L-L	Typically <4.5% full load L-N	Typically <4.5% full load L-N
Interference suppression	VDE 0875 G/N/K, EN61000-6-3, EN61000-6-2, others available on request					

## Winding Protection

There are various degrees of protection for the windings following the standard impregnation process, as can be seen here. The TOTAL+ butadienic black flexible coating is recommended for arduous applications.

Winding Protection:	STANDARD	STANDARD+	GREY	GREY+	TOTAL+ (3% de-rate may apply on certain models)
ECP3	Std	Option	Option	Option	Option
ECP28 and ECP32	-	Std	Option	Option	Option
NPE32, ECP34 to ECO46	-	-	Std	Option	Option

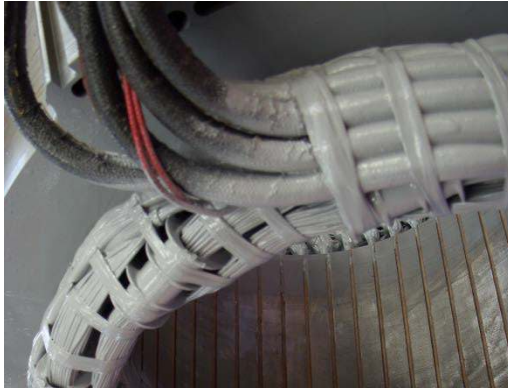

Grey treatment (marinization) on the left, TOTAL+ treatment shown on the right. The EG43 grey varnish, is an high temperature insulating enamel that forms a tough and flexible film, with excellent moisture and chemical protection. It is water and oil proof, and also protects windings from abrasion. It is applied spraying an over coating layer over the impregnated winding, or dipping the stator in a varnish barrel for superior treatments

The TOTAL+ is a protection system that makes Mecc Alte special. It is the ultimate winding treatment that offers truly superior performances when the environment is really harsh, or the application very demanding. It is a rubbery protection treatment, used to replace epoxies and silicones winding encapsulation. The TOTAL+ flexible black compound cures to a tough, resilient, glossy black thick coating that seals the copper against moisture and chemical attacks. Due to its encapsulation capability and flexibility, is also extremely resistant to the particle abrasion as it adsorbs the impacts. Moreover, the high flexibility leads to a long-trouble less life protection, as the compound follows elastically the thermal expansion cycles of the windings from the cold to the hot condition and vice versa without forming any cracks.

## Protection for Environment

In addition to protection on the windings themselves, the alternators can have increased ingress protection. Standard levels are IP23 with further upgrades available to include inlet filters, IP43 and IP45: 7% de-rates apply on inlet filters and IP43 protection. 20-30% de-rates apply for IP45 depending on alternator model.

Additional air exit louvres (called IP23+) are optionably retrofittable in the overall ECP32 to ECO 46 range, in order to comply to the most strict marine regulations.



## Construction

The robust mechanical structure withstands up to 5G in any direction and 9G vertically and its design permits easy access to the connections and components during routine maintenance check-ups. The mechanical design has used the most advanced FEM techniques. The materials used are: FEPI2 steel for the frame, C45 steel for the shaft and cast iron or aluminum pressure die cast for the end-brackets: fans are aluminum die casted either nylon fiber glass loaded, UL compliant materials. Rotors are dynamically balanced according grade 2.5 of ISO 1940-1.

## Terminals and Terminal Box

Easy access to regulators is assured through a pull out drawer or a drop down panel to allow safer adjustment. Large terminal boxes allow easy access of power cables, in the ECO43 and ECO46 higher power ranges the terminal allow the convenient choice of power cable or busbar connection with versatility of entry and connection. Current transformers are available as an option on series ECO 40, 43 and 46 with single or dual output.

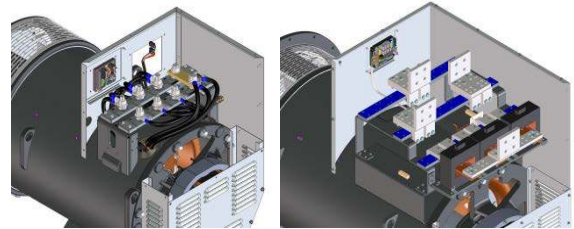

## Excitation and Regulation Systems

All ECP/ECO series have MAUX auxiliary winding to power the digital regulator. Both DSR and the DER1 are available to connect to PC through the DxR2 USB interface and DxR TERMINAL software to interrogate/download alarms & settings for analysis or for cloning other regulators. DER2 has got an integrated USB connection and can be connected to the PC without any optional connection boards. More settings such as LAMS, digital RAM based synchronous external control and soft start are obtainable through the DxR connection. Simple analogue potentiometers are available for the more usual adjustments.

Excitation Systems	DSR	DER1	DER2
ECP3 to ECO38	Std	Option	Option
ECO40 to ECO46	-	Std	Option
Parallel Operation	√	√	√
Mains Parallel	√	√	√
3 Phase Sensing (rms)	-	√	√
Accuracy	+/-1%	+/-0.5%	+/-0.5%
Remote Voltage Control	√	√	√
Alarm Log	√	√	√
Analogue and Digital Configurable	√	√	√
LAMS (Load Acceptance V/f)	√	√	√
APO (Active Protection Output)	√	√	√
Soft Start	√	√	√
High dynamic response	-	-	√
USB connection without external boards	-	-	√

For a given motor start duty a smaller machine may be selected – also enhanced by low sub-transient reactance values for non-linear loads. The whole range from 6.5 to 3400kVA is capable of >300% sustained short circuit current for up to 20 seconds.

## Optional PMG3

PMG3 can be retro fit or factory fit on ECO 40, 43 and 46 series. This smart MeccAlte design allows an easy fix kit, through a tapered cone coupling and a simple replacement of the rear air louvre. PMG3 is also available on ECO 38, when ordered from the factory.

The complete AVR range is fully compatible with both MAUX and PMG3 systems, this minimises spare part management and flexibility of stock as one AVR suits all applications. The PMG3 is delivering the same amount of kVA available with the MAUX.

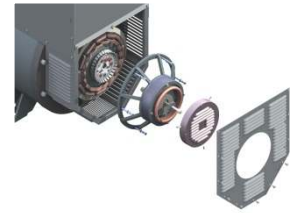

## Accessories

Additional optionals can be fit on our alternator series, such as PTC thermistors or PT100 both on windings and bearings, space heaters, high and low profile of terminal boxes (on most series), air filter clogging sensors, rotating diode bridge failure sensor (RBD), power factor controller for parallel operation (PFR/2), parallel devices (standard from ECO 40), air filters, IP43 and IP45 protections, marine IP23 + protection for SOLAS requirements and many others.

## Deration coefficients

Altitude (meters)	Ambient temperature (Celsius)					
	25	40	45	50	55	60
$\leq 1000$	1.07	1	0.96	0.93	0.91	0.89
$> 1000 \leq 1500$	1.01	0.96	0.92	0.89	0.87	0.84
$> 1500 \leq 2000$	0.96	0.91	0.87	0.84	0.83	0.79
$> 2000 \leq 3000$	0.9	0.85	0.81	0.78	0.76	0.73

## Notes on short circuit curves

The indicated coefficients have to be used to correct the three phase short circuit curves values as a function of the rated voltage.

The indicated coefficient have to be used to correct the three phase short circuit curves values as a function of the type of short circuit voltage.

50 Hz		60 Hz	
Voltage	Factor	Voltage	Factor
380	0.93X	415	0.85X
400	1X	440	0.90X
415	1.04X	460	0.95X
440	1.10X	480	1X

	3 phase	2 phase L-L	1 phase L-N
<i>Istantaneous</i>	1X	0.87X	1.30X
<i>Minimum</i>	1X	1.80X	3.20X
<i>Sustained</i>	1X	1.50X	2.50X
<i>Max Duration</i>	20 sec.	10 sec.	4 sec.

All the curves are shown for series or parallel star connection at 400V 50 Hz or 480V 60 Hz. If the unit is reconnected from series to parallel star, the additional coefficient is 2X. From series star to series delta, it is 1.72X. From series star to parallel delta, it is 3.44X.

## General characteristics

Pole number	4	Insulation class	H
Phase number	3	Protection class	IP23
Number of wires	12	NDE Bearing type	6311.2RS
Execution	Brushless	DE Bearing type	6314.2Z
Regulator type	DSR	Maximum Overspeed	2250
Winding pitch	2/3	Altitude	0-1000
Code voltage reference	T0405S3	Balancing	ISO1940-1

## Ratings 50Hz

kVA / kW @ Temp. Rise / Ambient °C - 0.8 PF		STANDBY-163/27				STANDBY-150/40				H-125/40				F-105/40				B-80/40			
Series	Star Y	380V	400V	415V	440V	380V	400V	415V	440V	380V	400V	415V	440V	380V	400V	415V	440V	380V	400V	415V	440V
	Parallel Star YY	190V	200V	208V	220V	190V	200V	208V	220V	190V	200V	208V	220V	190V	200V	208V	220V	190V	200V	208V	220V
	Series Delta Δ	220V	230V	240V	254V	220V	230V	240V	254V	220V	230V	240V	254V	220V	230V	240V	254V	220V	230V	240V	254V
	Parallel Delta ΔΔ	110V	115V	120V	127V	110V	115V	120V	127V	110V	115V	120V	127V	110V	115V	120V	127V	110V	115V	120V	127V
<b>ECP34 1S4 A</b>	<b>kVA</b>	95	<b>95</b>	95	78	90	<b>90</b>	90	75	85	<b>85</b>	85	70	77	<b>77</b>	77	63	68	<b>68</b>	68	56
	<b>kW</b>	76	<b>76</b>	76	62	72	<b>72</b>	72	60	68	<b>68</b>	68	56	61,6	<b>61,6</b>	61,6	50,4	54,4	<b>54,4</b>	54,4	44,8
<b>ECP34 2S4 A</b>	<b>kVA</b>	116	<b>116</b>	116	94	110	<b>110</b>	110	90	105	<b>105</b>	105	85	95	<b>95</b>	95	77	84	<b>84</b>	84	68
	<b>kW</b>	93	<b>93</b>	93	75	88	<b>88</b>	88	72	84	<b>84</b>	84	68	76	<b>76</b>	76	61,6	67	<b>67</b>	67	54
<b>ECP34 1L4 A</b>	<b>kVA</b>	148	<b>148</b>	148	124	143	<b>143</b>	143	120	135	<b>135</b>	135	114	121	<b>121</b>	121	103	108	<b>108</b>	108	91
	<b>kW</b>	118	<b>118</b>	118	99	114	<b>114</b>	114	96	108	<b>108</b>	108	91	97	<b>97</b>	97	82	86	<b>86</b>	86	73
<b>ECP34 2L4 A</b>	<b>kVA</b>	164	<b>164</b>	164	136	158	<b>158</b>	158	131	150	<b>150</b>	150	125	136	<b>136</b>	136	113	120	<b>120</b>	120	100
	<b>kW</b>	131	<b>131</b>	131	109	126	<b>126</b>	126	105	120	<b>120</b>	120	100	109	<b>109</b>	109	90,4	96	<b>96</b>	96	80
<b>ECP34 3L4 A</b>	<b>kVA</b>	170	<b>175</b>	175	164	164	<b>169</b>	169	158	155	<b>160</b>	160	150	140	<b>145</b>	145	135	124	<b>128</b>	128	120
	<b>kW</b>	136	<b>140</b>	140	131	131	<b>135</b>	135	126	124	<b>128</b>	128	120	112	<b>116</b>	116	108	99	<b>102</b>	102	96

## Ratings 60Hz

kVA / kW @ Temp. Rise / Ambient °C - 0.8 PF		STANDBY-163/27				STANDBY-150/40				H-125/40				F-105/40				B-80/40			
Series	Star Y	415V	440V	460V	480V	415V	440V	460V	480V	415V	440V	460V	480V	415V	440V	460V	480V	415V	440V	460V	480V
	Parallel Star YY	208V	220V	230V	240V	208V	220V	230V	240V	208V	220V	230V	240V	208V	220V	230V	240V	208V	220V	230V	240V
	Series Delta Δ	240V	254V	265V	277V	240V	254V	265V	277V	240V	254V	265V	277V	240V	254V	265V	277V	240V	254V	265V	277V
	Parallel Delta ΔΔ	120V	127V	133V	138V	120V	127V	133V	138V	120V	127V	133V	138V	120V	127V	133V	138V	120V	127V	133V	138V
<b>ECP34 1S4 A</b>	<b>kVA</b>	106	114	114	<b>114</b>	101	108	108	<b>108</b>	95	102	102	<b>102</b>	85,5	92	92	<b>92</b>	76	81	81	<b>81</b>
	<b>kW</b>	85	91	91	<b>91</b>	81	86	86	<b>86</b>	76	82	82	<b>81,6</b>	68,4	73,6	73,6	<b>73,6</b>	60,8	64,8	64,8	<b>64,8</b>
<b>ECP34 2S4 A</b>	<b>kVA</b>	127	139	139	<b>139</b>	120	132	132	<b>132</b>	115	126	126	<b>126</b>	104	114	114	<b>114</b>	92	101	101	<b>101</b>
	<b>kW</b>	102	111	111	<b>111</b>	96	106	106	<b>106</b>	92	101	101	<b>101</b>	83,2	91,2	91,2	<b>91,2</b>	74	81	81	<b>81</b>
<b>ECP34 1L4 A</b>	<b>kVA</b>	153	165	178	<b>178</b>	148	159	172	<b>172</b>	140	150	162	<b>162</b>	125	135	146	<b>146</b>	112	120	130	<b>130</b>
	<b>kW</b>	122	132	142	<b>142</b>	118	127	138	<b>138</b>	112	120	130	<b>130</b>	100	108	117	<b>117</b>	90	96	104	<b>104</b>
<b>ECP34 2L4 A</b>	<b>kVA</b>	163	185	196	<b>196</b>	158	178	189	<b>189</b>	150	170	180	<b>180</b>	132	150	163	<b>163</b>	120	136	144	<b>144</b>
	<b>kW</b>	130	148	157	<b>157</b>	126	142	151	<b>151</b>	120	136	144	<b>144</b>	106	120	130	<b>130</b>	96	109	115	<b>115</b>
<b>ECP34 3L4 A</b>	<b>kVA</b>	180	202	210	<b>210</b>	174	195	202	<b>202</b>	165	185	192	<b>192</b>	150	160	173	<b>173</b>	132	148	154	<b>154</b>
	<b>kW</b>	144	162	168	<b>168</b>	139	156	162	<b>162</b>	132	148	154	<b>154</b>	120	128	138	<b>138</b>	106	118	123	<b>123</b>

## Reactance &amp; Time constants- Class H / 400V

Unsaturated (ref. EN60034-4)			ECP34 1S4 A	ECP34 2S4 A	ECP34 1L4 A	ECP34 2L4 A	ECP34 3L4 A
<b>X<sub>d</sub></b>	Direct-axis synchronous reactance	%	334,7	236,9	228,7	247,2	216,3
<b>X'<sub>d</sub></b>	Direct-axis transient reactance	%	23	18,1	15,9	15,2	17,9
<b>X''<sub>d</sub></b>	Direct-axis subtransient reactance	%	7,62	5,87	7,83	6,39	7,52
<b>X<sub>q</sub></b>	Quadrature-axis synchronous reactance	%	175,6	154,1	140,1	125,8	147,3
<b>X'<sub>q</sub></b>	Quadrature-axis transient reactance	%	175,6	154,1	140,1	125,8	147,3
<b>X''<sub>q</sub></b>	Quadrature-axis subtransient reactance	%	30,4	32,1	29,2	27,3	32
<b>X<sub>2</sub></b>	Negative-sequence reactance	%	19,8	19,1	17,7	17	19,9
<b>X<sub>0</sub></b>	Zero sequence reactance	%	3,71	3,61	2,78	2,58	3,06
Saturated							
<b>X<sub>d</sub></b>	Direct-axis synchronous reactance	%	284,5	201,4	194,4	210,1	183,9
<b>X'<sub>d</sub></b>	Direct-axis transient reactance	%	19,5	15,4	13,5	13	15,2
<b>X''<sub>d</sub></b>	Direct-axis subtransient reactance	%	6,48	4,99	6,65	5,43	6,39
<b>X<sub>q</sub></b>	Quadrature-axis synchronous reactance	%	149,3	131	119,1	106,9	125,2
<b>X'<sub>q</sub></b>	Quadrature-axis transient reactance	%	149,3	131	119,1	106,9	125,2
<b>X''<sub>q</sub></b>	Quadrature-axis subtransient reactance	%	25,8	27,3	24,9	23,2	27,2
<b>X<sub>2</sub></b>	Negative-sequence reactance	%	14,8	16,2	15,1	14,4	16,9
<b>X<sub>0</sub></b>	Zero sequence reactance	%	3,71	3,61	2,78	2,58	3,06
<b>K<sub>cc</sub></b>	Short circuit ratio		0,5	0,47	0,45	0,48	0,48
<b>T'<sub>d</sub></b>	Transient time constant	sec	0,042	0,039	0,039	0,04	0,04
<b>T''<sub>d</sub></b>	Subtransient time constant	sec	0,006	0,006	0,008	0,01	0,01
<b>T'<sub>do</sub></b>	Open circuit time constant	sec	1,5	1,7	1,85	1,9	1,91
<b>T<sub>a</sub></b>	Armature time constant	sec	0,015	0,015	0,017	0,017	0,017

## Additional information - Class H / 400V

<b>I<sub>o</sub></b>	Excitation current at no load	A	0,5	0,6	0,6	0,4	0,45
<b>I<sub>c</sub></b>	Excitation current at full load	A	2,3	2,2	2,1	2,4	2,5
Overload			1 hour in a 6 hours period 110% rated load				
Overload per 20 sec.		%	300				
Heat dissipation		W	6317	7106	8254	8755	8898
Telephone Harmonic Factor - THF		%	<2				
Waveform Distors.(THD) full load LL/LN		%	2,9 / 3	2,8 / 2,9	2,3 / 2,5	2,3 / 2,4	2,4 / 2,5
Waveform Distors.(THD) no load LL/LN		%	1,6 / 1,8	1,8 / 1,9	1,7 / 1,9	1,7 / 1,8	1,7 / 1,8

## Reactance & Time constants- Class H / 480V

Unsaturated (ref. EN60034-4)			ECP34 1S4 A	ECP34 2S4 A	ECP34 1L4 A	ECP34 2L4 A	ECP34 3L4 A
<b>X<sub>d</sub></b>	Direct-axis synchronous reactance	%	334,7	236,9	228,7	247,2	223,3
<b>X'<sub>d</sub></b>	Direct-axis transient reactance	%	23	18,1	15,9	15,2	18,5
<b>X''<sub>d</sub></b>	Direct-axis subtransient reactance	%	7,62	5,87	7,83	6,39	7,76
<b>X<sub>q</sub></b>	Quadrature-axis synchronous reactance	%	175,6	154,1	140,1	125,8	152
<b>X'<sub>q</sub></b>	Quadrature-axis transient reactance	%	175,6	154,1	140,1	125,8	152
<b>X''<sub>q</sub></b>	Quadrature-axis subtransient reactance	%	30,4	32,1	29,2	27,3	33,1
<b>X<sub>2</sub></b>	Negative-sequence reactance	%	19,8	19,1	17,7	17	20,5
<b>X<sub>0</sub></b>	Zero sequence reactance	%	3,71	3,61	2,78	2,58	3,16
<b>Saturated</b>							
<b>X<sub>d</sub></b>	Direct-axis synchronous reactance	%	284,5	201,4	194,4	210,1	189,8
<b>X'<sub>d</sub></b>	Direct-axis transient reactance	%	19,5	15,4	13,5	13	15,7
<b>X''<sub>d</sub></b>	Direct-axis subtransient reactance	%	6,48	4,99	6,65	5,43	6,6
<b>X<sub>q</sub></b>	Quadrature-axis synchronous reactance	%	149,3	131	119,1	106,9	129,2
<b>X'<sub>q</sub></b>	Quadrature-axis transient reactance	%	149,3	131	119,1	106,9	129,2
<b>X''<sub>q</sub></b>	Quadrature-axis subtransient reactance	%	25,8	27,3	24,9	23,2	28,1
<b>X<sub>2</sub></b>	Negative-sequence reactance	%	16,8	16,2	15,1	14,4	17,4
<b>X<sub>0</sub></b>	Zero sequence reactance	%	3,71	3,61	2,78	2,58	3,16
<b>K<sub>cc</sub></b>	Short circuit ratio		0,5	0,47	0,45	0,48	0,48
<b>T'<sub>d</sub></b>	Transient time constant	sec	0,042	0,039	0,039	0,04	0,04
<b>T''<sub>d</sub></b>	Subtransient time constant	sec	0,006	0,006	0,008	0,01	0,01
<b>T'<sub>do</sub></b>	Open circuit time constant	sec	1,5	1,7	1,85	1,9	1,91
<b>T<sub>a</sub></b>	Armature time constant	sec	0,015	0,015	0,017	0,017	0,017

## Additional information - Class H / 480V

<b>I<sub>o</sub></b>	Excitation current at no load	A	0,7	0,5	0,5	0,5	0,4
<b>I<sub>c</sub></b>	Excitation current at full load	A	2,2	2,2	2,0	2,6	2,5
<b>Overload</b>			1 hour in a 6 hours period 110% rated load				
Overload per 20 sec.		%	300				
Heat dissipation		W	5766	6663	7109	7579	7575
Telephone Interference Factor - TIF			<40	<40	<40	<40	<40
Waveform Distors.(THD) full load LL/LN		%	2,9 / 3	2,8 / 2,9	2,3 / 2,5	2,3 / 2,4	2,4 / 2,5
Waveform Distors.(THD) no load LL/LN		%	1,6 / 1,8	1,8 / 1,9	1,7 / 1,9	1,7 / 1,8	1,7 / 1,8

## Efficiencies @ 50Hz

Models		380V 50Hz					400V 50Hz					415V 50Hz					440V 50Hz				
		0.25	0.5	0.75	1	1.1	0.25	0.5	0.75	1	1.1	0.25	0.5	0.75	1	1.1	0.25	0.5	0.75	1	1.1
ECP34 1S4 A	%	86,2	89,9	91,6	91,4	91,1	86,0	90,0	91,9	91,5	91,1	85,8	90,0	91,8	91,2	90,8	85,8	89,8	91,5	91,0	90,6
ECP34 2S4 A	%	87,2	90,6	92,2	92,1	92,0	87,0	90,7	92,5	92,2	92,0	86,8	90,7	92,4	91,9	91,6	86,8	90,5	92,1	91,7	91,5
ECP34 1L4 A	%	88,2	91,6	93,1	92,8	92,5	88,2	91,7	93,4	92,9	92,5	88,1	91,7	93,2	92,6	92,2	88,0	91,6	93,0	92,4	92,0
ECP34 2L4 A	%	89,2	91,9	93,2	93,1	92,9	89,0	92,0	93,5	93,2	93,0	88,8	92,0	93,4	92,9	92,7	88,8	91,8	93,1	92,7	92,5
ECP34 3L4 A	%	89,8	92,2	93,4	93,4	93,2	89,6	92,3	93,7	93,5	93,3	89,4	92,3	93,6	93,2	93,0	89,4	92,1	93,3	93,0	92,8

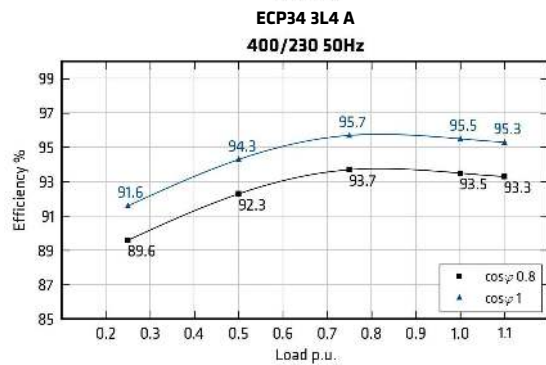
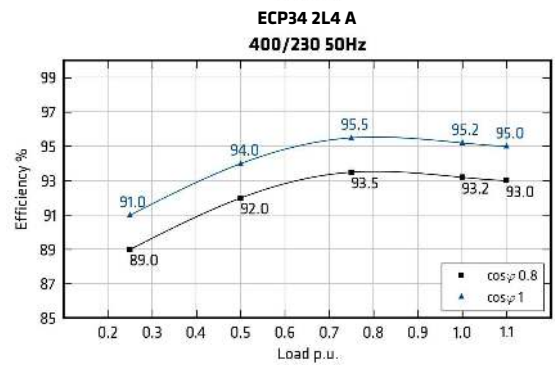
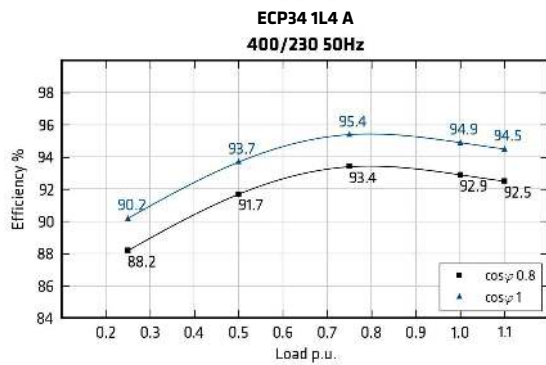
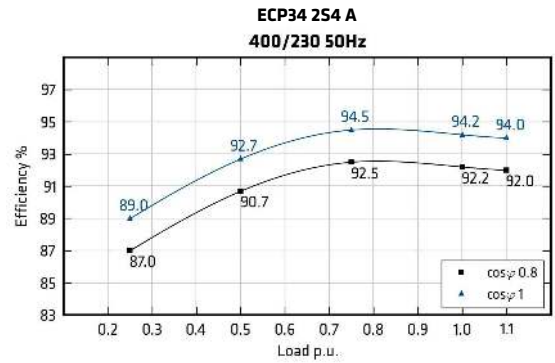
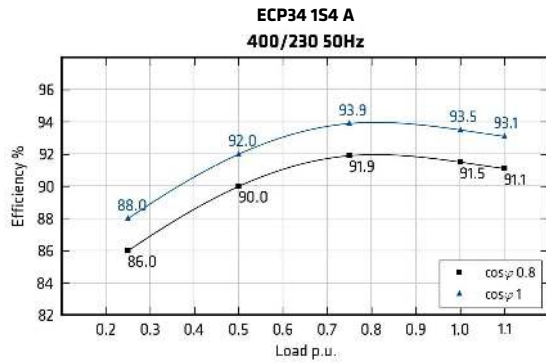

## Efficiencies @ 60Hz

Models		415V 60Hz					440V 60Hz					460V 60Hz					480V 60Hz				
		0.25	0.5	0.75	1	1.1	0.25	0.5	0.75	1	1.1	0.25	0.5	0.75	1	1.1	0.25	0.5	0.75	1	1.1
ECP34 1S4 A	%	87,7	91,5	93,3	92,7	92,2	87,7	91,6	93,5	93,2	93,0	87,7	91,7	93,6	93,3	93,1	87,5	91,8	93,8	93,4	93,1
ECP34 2S4 A	%	88,2	92,0	93,6	93,1	92,7	88,2	92,1	93,8	93,6	93,4	88,2	92,2	93,9	93,7	93,5	88,0	92,3	94,1	93,8	93,5
ECP34 1L4 A	%	89,3	93,1	94,5	94,0	93,6	89,4	93,3	95,0	94,5	94,1	89,5	93,5	95,2	94,7	94,3	89,3	93,6	95,3	94,8	94,4
ECP34 2L4 A	%	90,2	93,5	94,7	94,3	94,1	90,2	93,6	94,9	94,8	94,6	90,2	93,7	95,0	94,9	94,7	90,0	93,8	95,2	95,0	94,8
ECP34 3L4 A	%	91,2	93,8	95,0	94,6	94,4	91,2	93,9	95,2	95,1	94,9	91,2	94,0	95,3	95,2	95,0	91,0	94,1	95,5	95,3	95,1

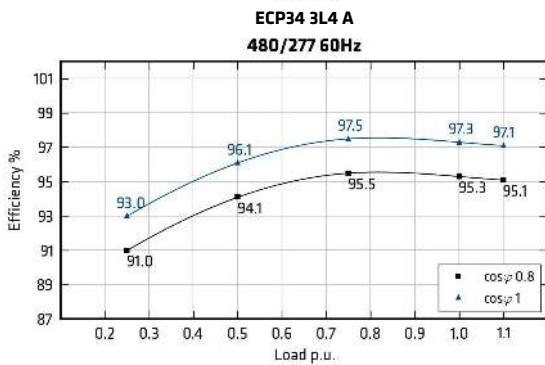
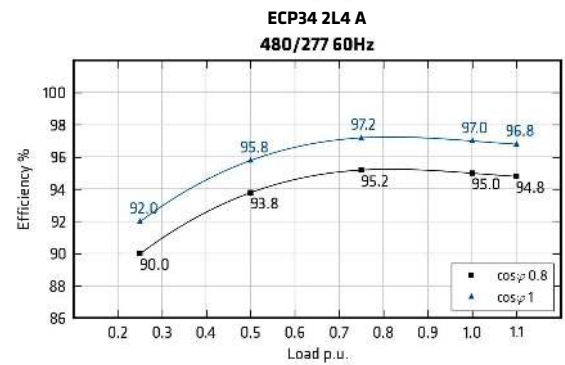
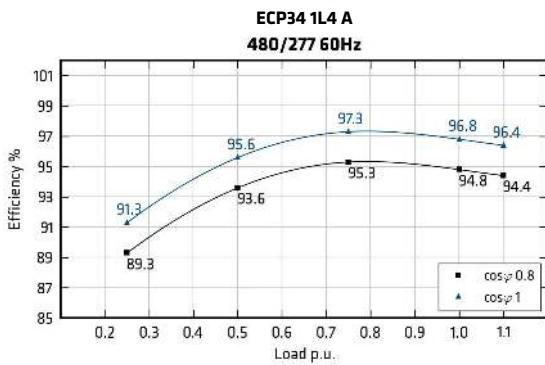
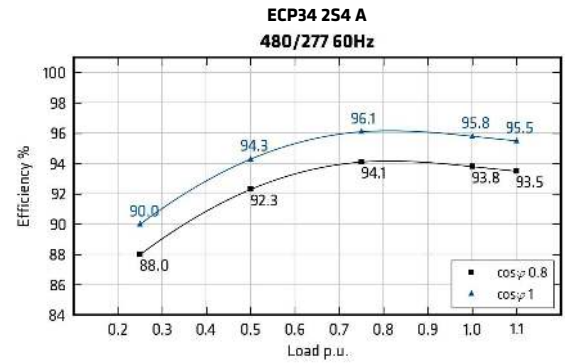
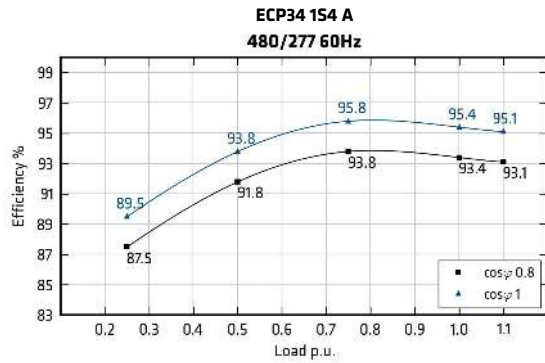

## Transients voltage

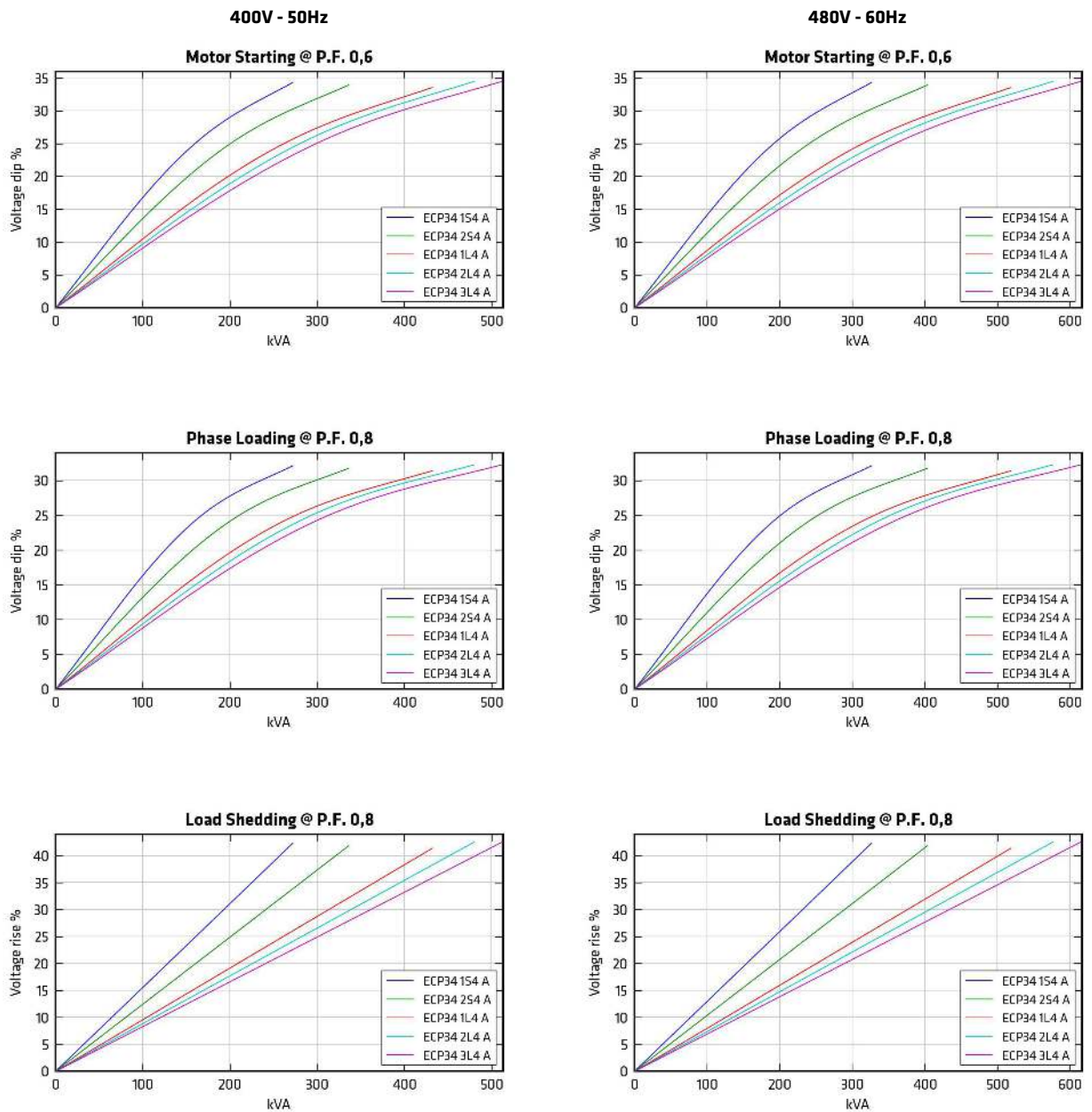

In order to scale transient curves as a function of a power factor or voltage if not indicated, please proceed as follows:

Power Factor coefficient corrector (PFCC), to be used on power factor 0.6 curves:

$$PFCC = \frac{\sin(\text{ARCCos}(PF_{\text{new}}))}{0.8}$$

Example. The PFCC at power factor 0.3 is 1.192 [  $PFCC = \frac{\sin(\text{ARCCos}(0.3))}{0.8}$  ]. This means that the voltage fall at a given power at pf 0.3 is equivalent to the one that can be read on the pf 0.6 curve if the load is considered 1.192 times bigger (19% higher value. ).

In this example, a 100 kVA load insertion at pf 0.3 is equivalent in voltage fall to a 119kVA load insertion at pf 0.6.

Voltage coefficient corrector (VCC):

$$VCC = \left(\frac{400}{V_{\text{new}}}\right)^2 \text{ if } 50 \text{ Hz}; \quad VCC = \left(\frac{480}{V_{\text{new}}}\right)^2 \text{ if } 60 \text{ Hz}$$

Example. VCC at 415V 60 Hz is 1.338 [  $VCC = \left(\frac{480}{415}\right)^2$  ]. This means that the voltage fall at a given power at 415V is equivalent to the one that can be read on the power factor 0.6 curve if the load is considered 1.338 times bigger (33% higher value. ).

In this example, a 100 kVA load insertion at 415V is equivalent in voltage fall to a 133kVA load insertion at 480V.

50Hz Short circuit decrement curves - No load excitation at rated speed

ECP34 1S4 A

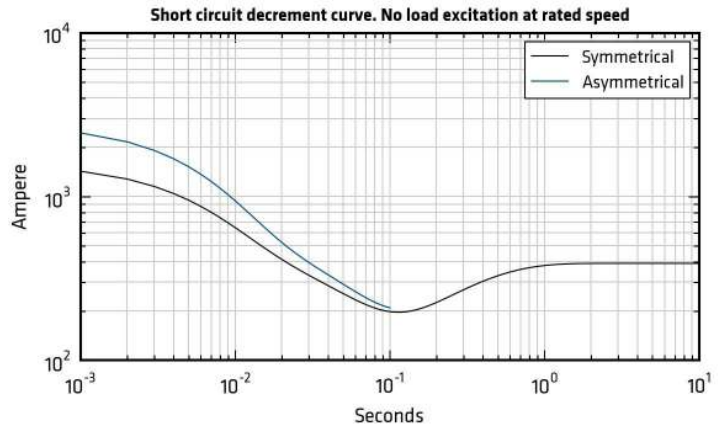

ECP34 2S4 A

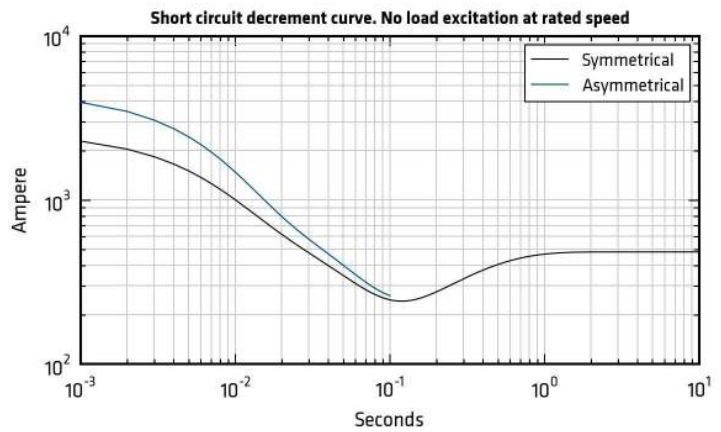

ECP34 1L4 A

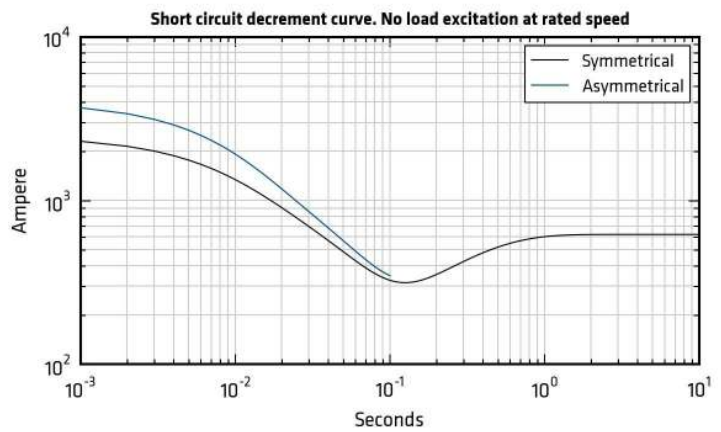

ECP34 2L4 A

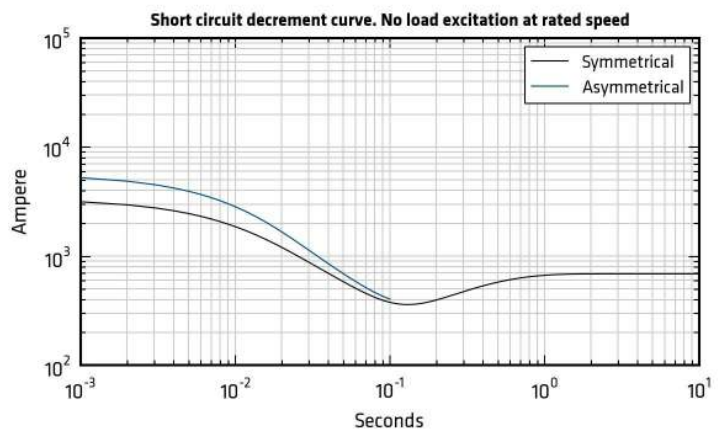

\*Please refer to tables at page 6

50Hz Short circuit decrement curves - No load excitation at rated speed

ECP34 3L4 A

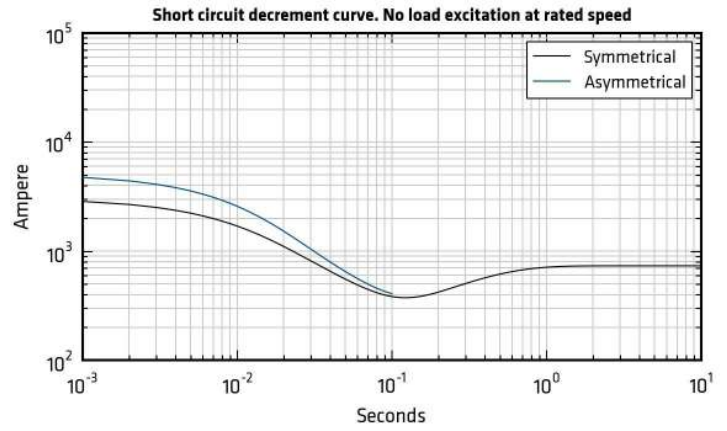

\*Please refer to tables at page 6

60Hz Short circuit decrement curves - No load excitation at rated speed

ECP34 1S4 A

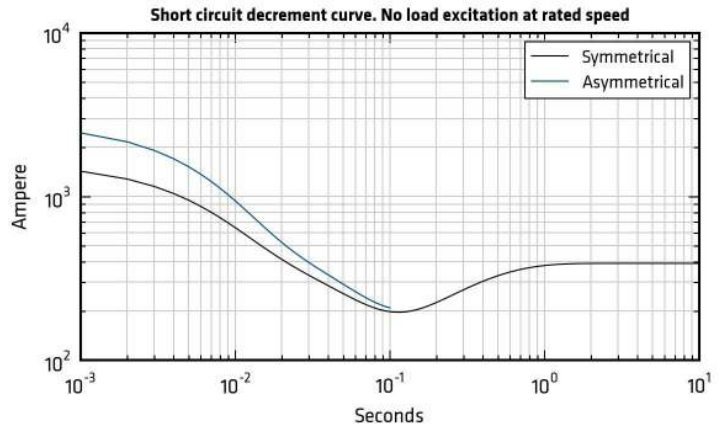

ECP34 2S4 A

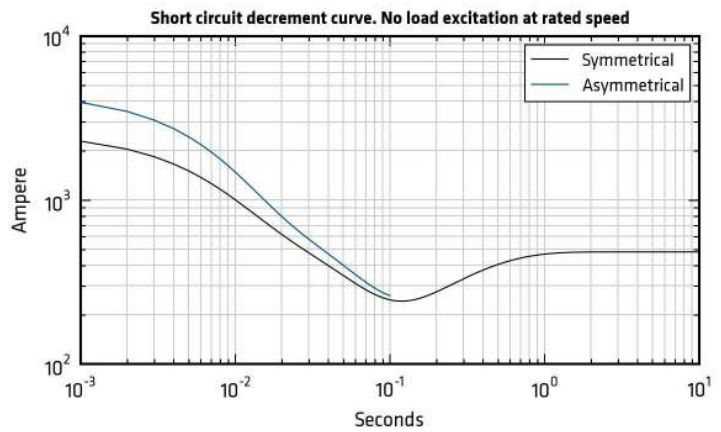

ECP34 1L4 A

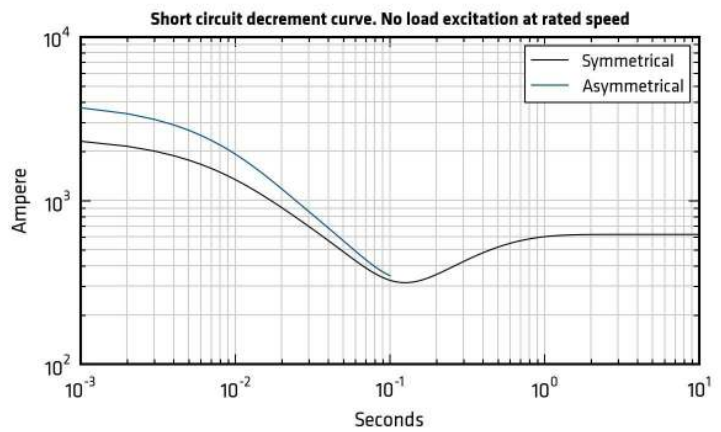

ECP34 2L4 A

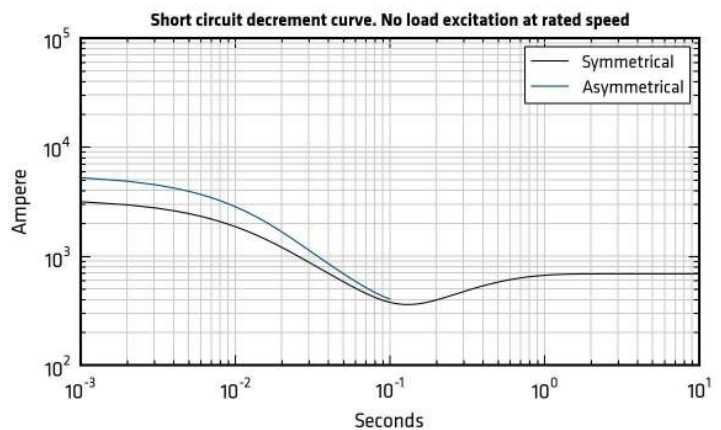

\*Please refer to tables at page 6

60Hz Short circuit decrement curves - No load excitation at rated speed

ECP34 3L4 A

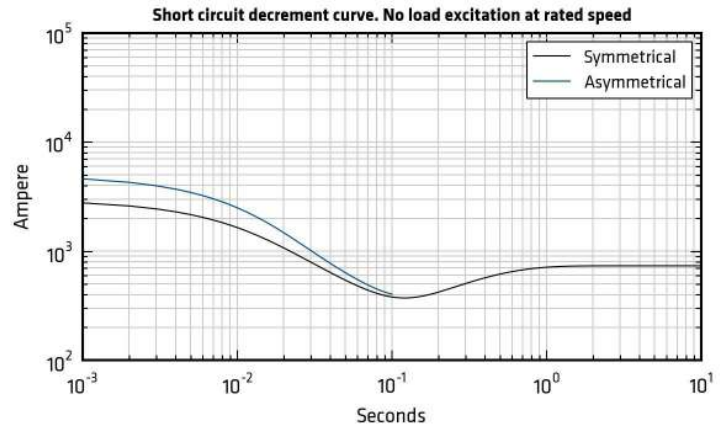

\*Please refer to tables at page 6

## Additional Characteristics

Data	ECP34 1S4 A		ECP34 2S4 A		ECP34 1L4 A		ECP34 2L4 A		ECP34 3L4 A		
	50Hz	60Hz	50Hz	60Hz	50Hz	60Hz	50Hz	60Hz	50Hz	60Hz	
Damper cage	Aluminium										
Stator Winding Resistance (20°C)	Ω	0,03		0,02		0,016		0,015		0,015	
Rotor Winding Resistance (20°C)	Ω	2,477		2,951		4,142		3,577		4,35	
Stator Exciter Resistance (20°C)	Ω	15,28		15,28		15,28		15,28		15,28	
Rotor Exciter Resistance (20°C)	Ω	0,41		0,41		0,41		0,41		0,41	
Weight of complete generator	kg	331,0		409,0		467,0		481,0		485,0	
Unbalanced magnetic pull	kN/mm	4,9		5,1		5,7		5,6		5,4	
Air flow	m <sup>3</sup> /min	19,3	23,0	19,3	23,0	19,3	23,0	19,3	23,0	19,3	23,0
Noise level at 1m/7m	dB(A)	79/65	83/69	79/65	83/69	79/65	83/69	79/65	83/69	79/65	83/69

## PQ Diagram

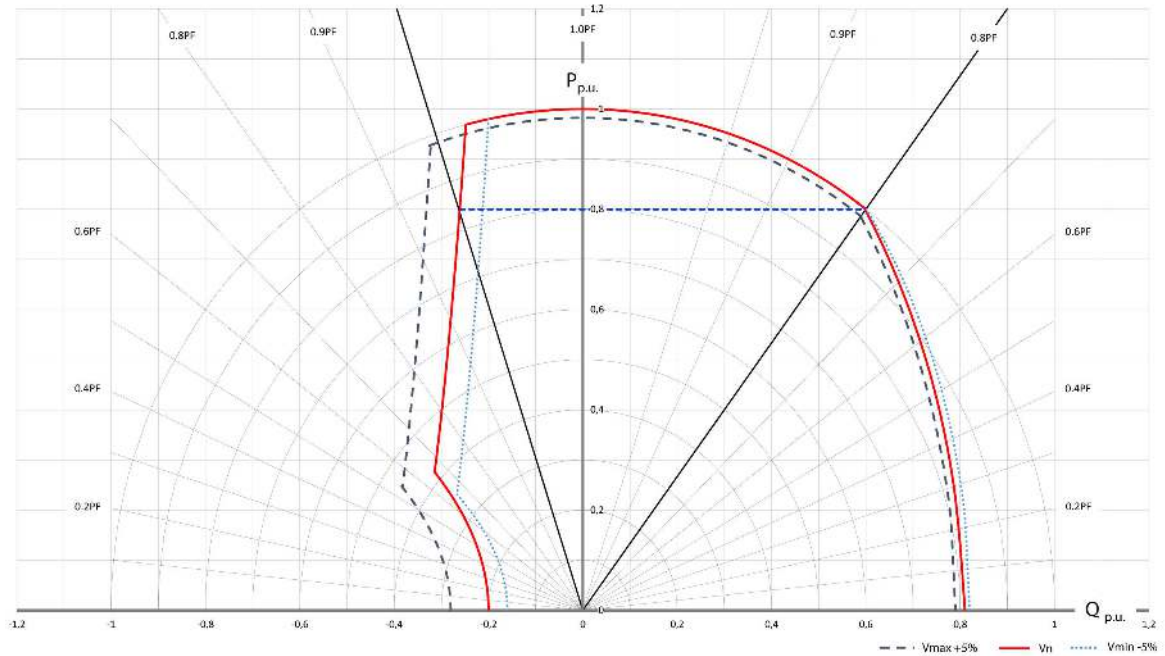

ECP34 1S4 A

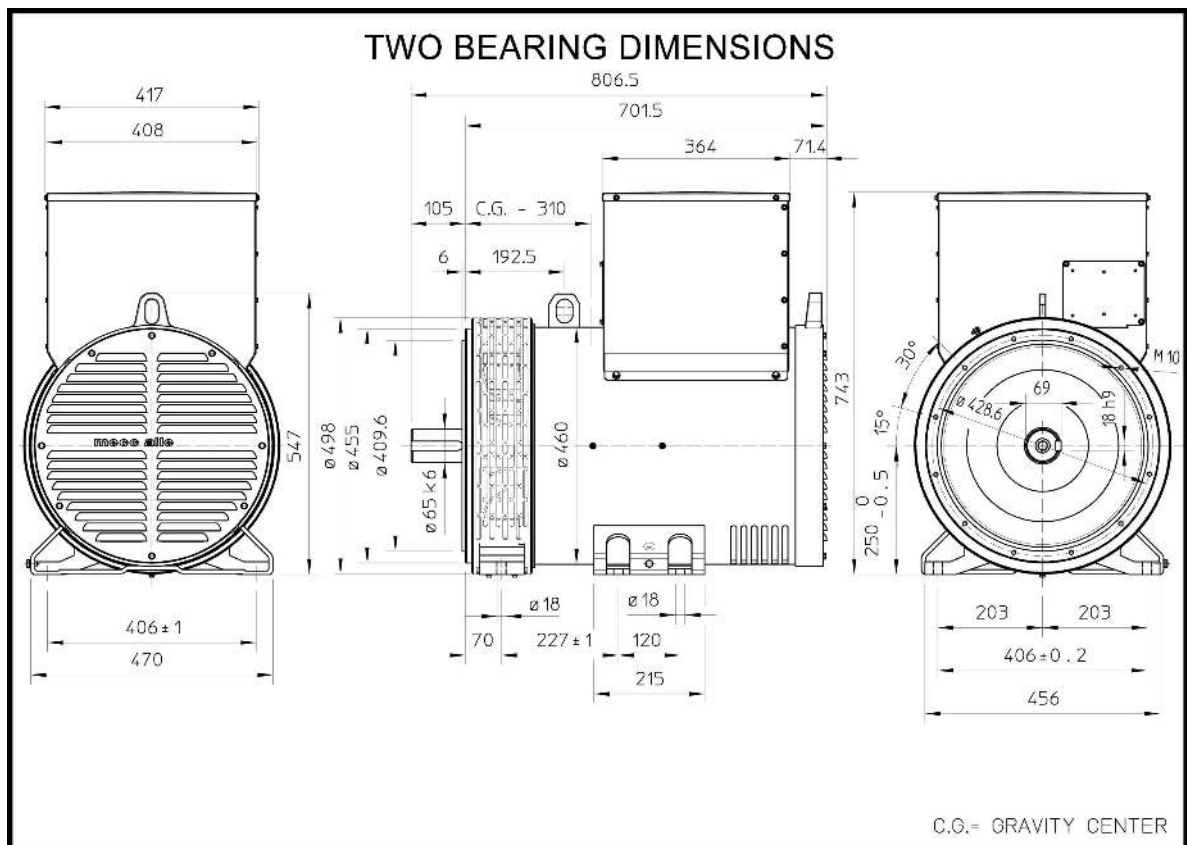
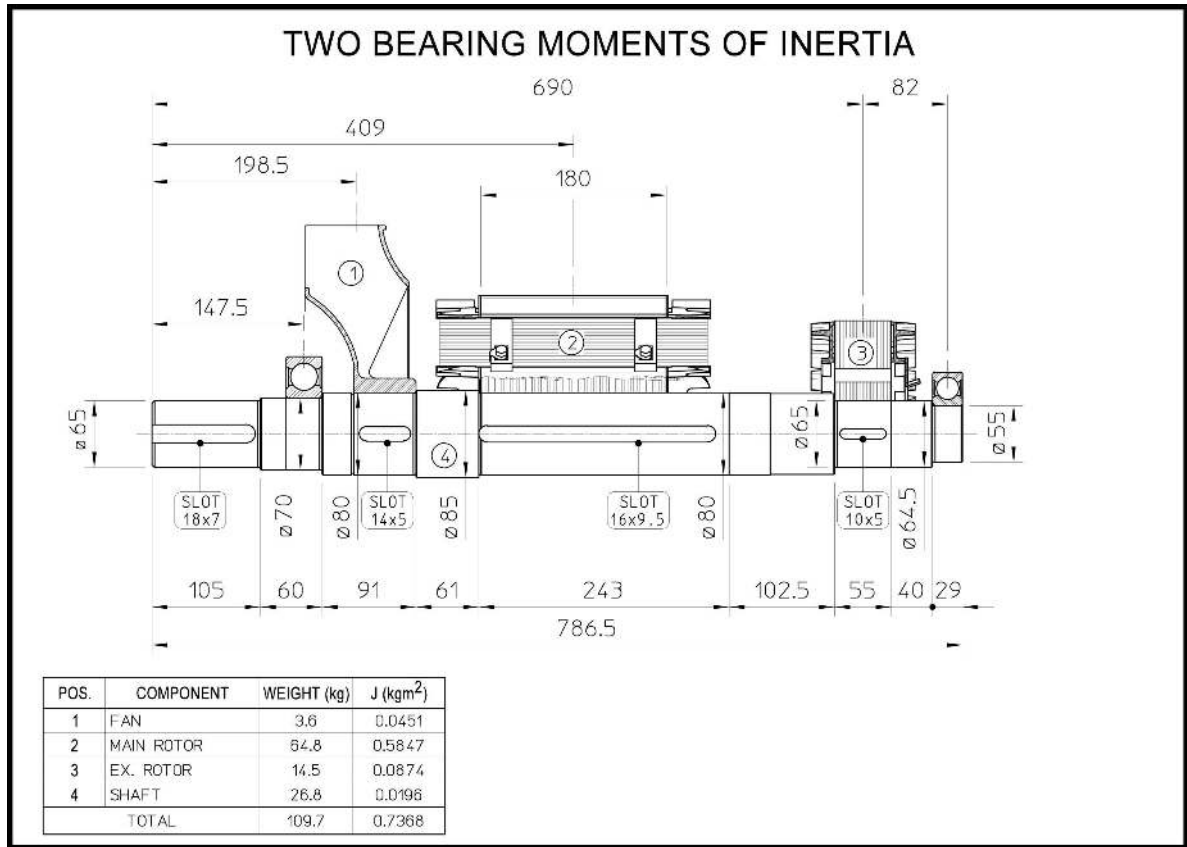

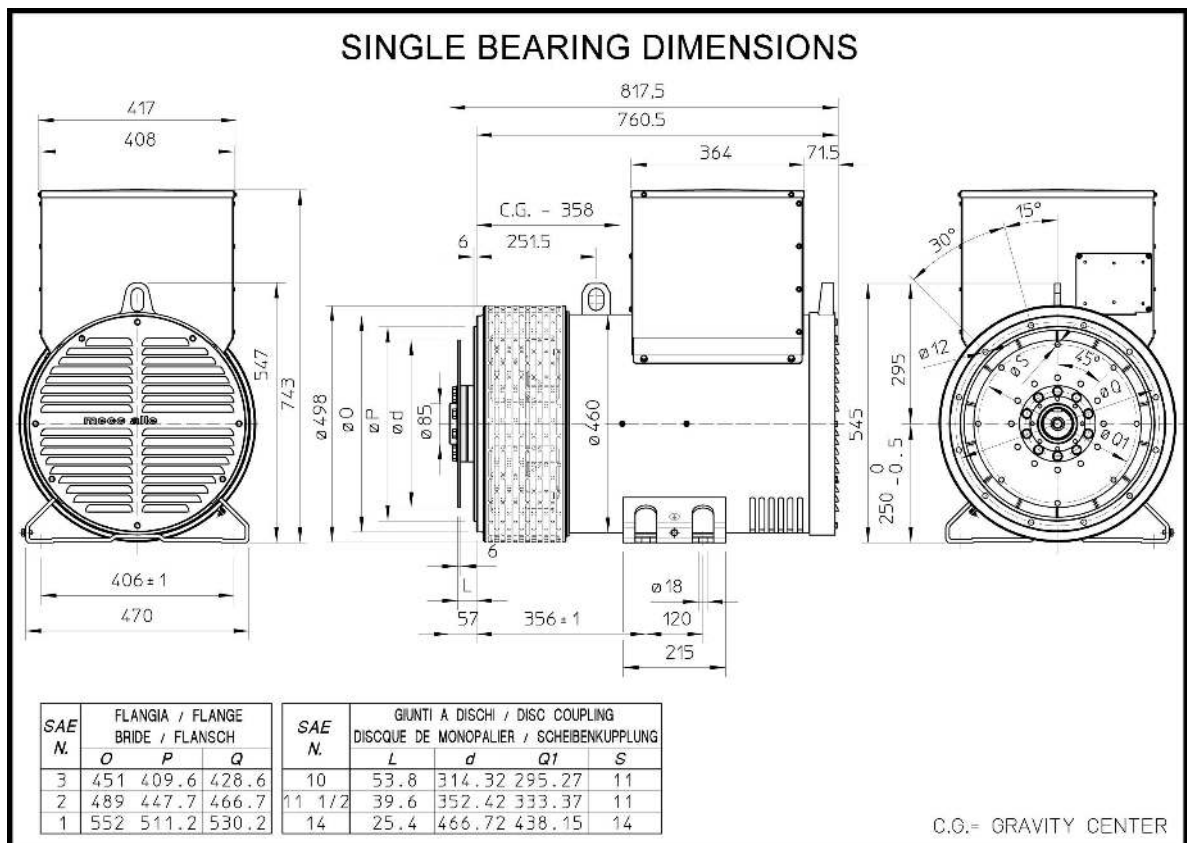
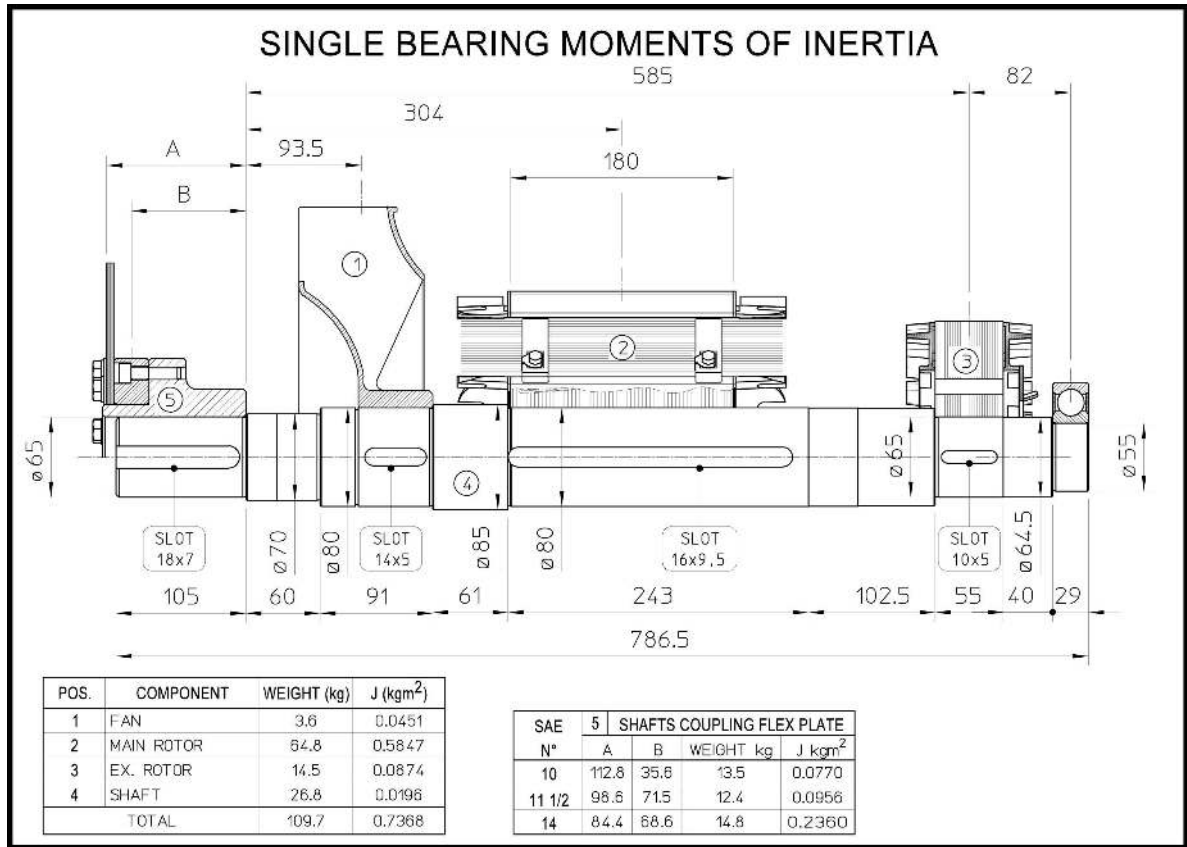

ECP34 2S4 A

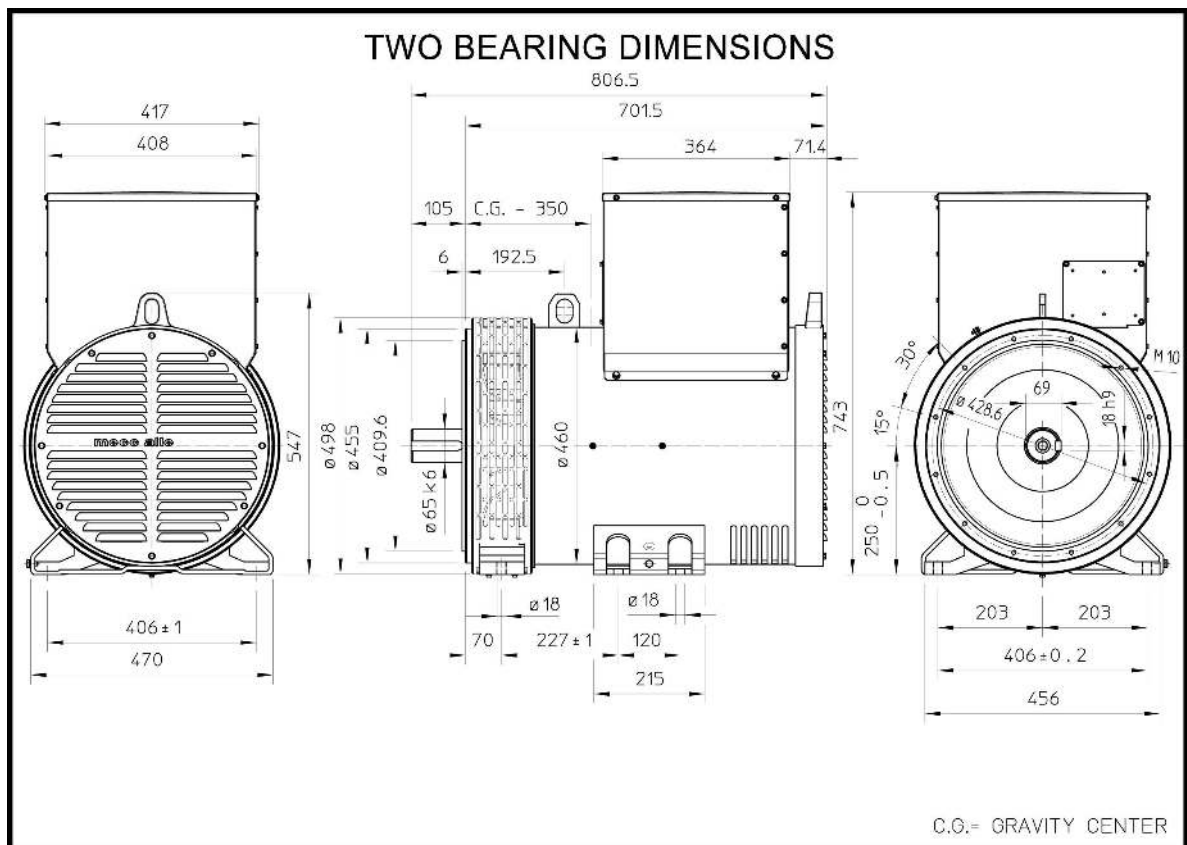
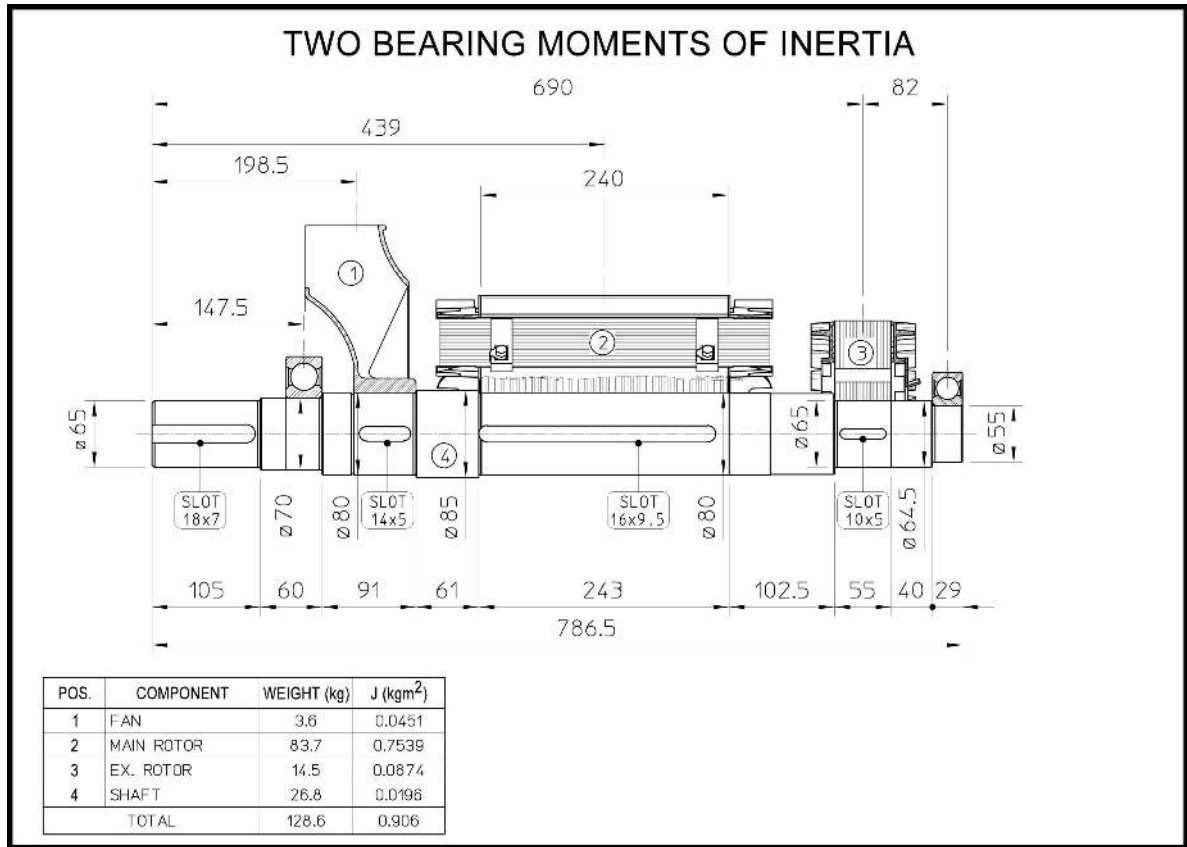

ECP34 2S4 A

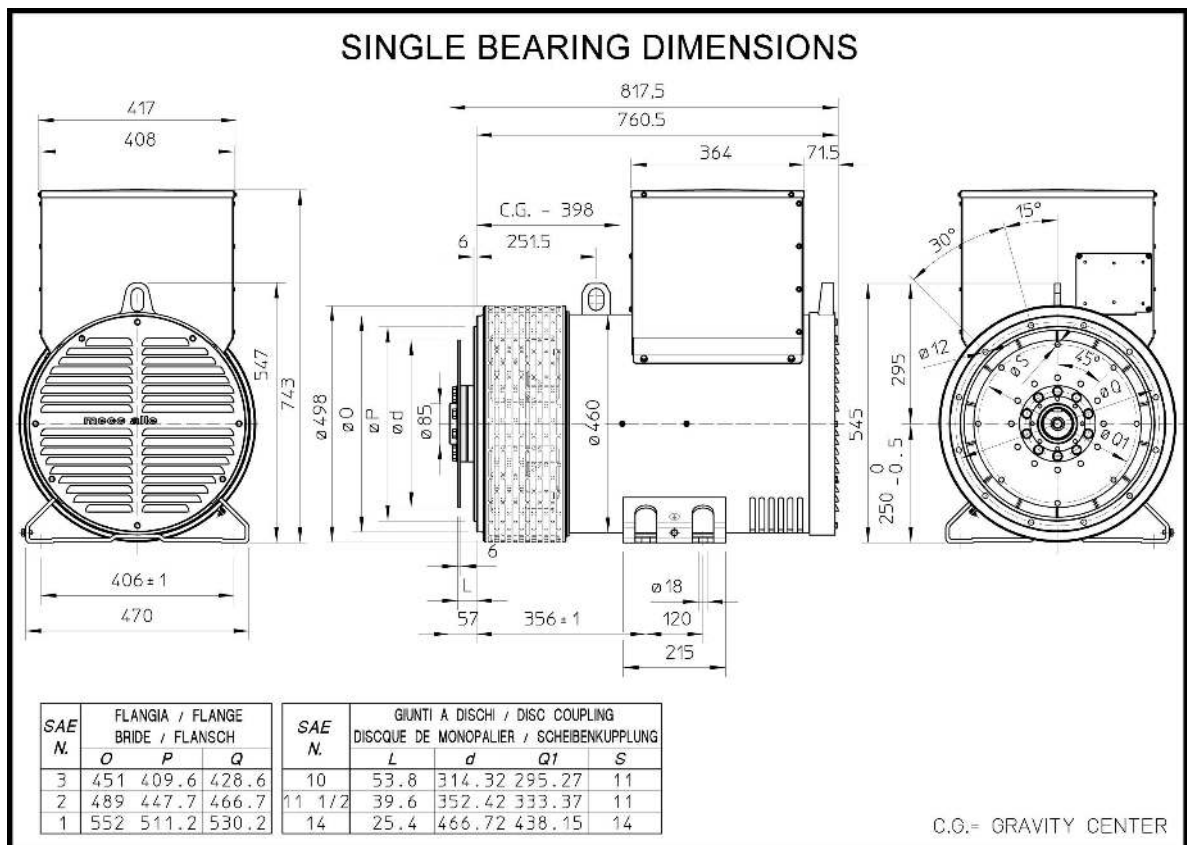
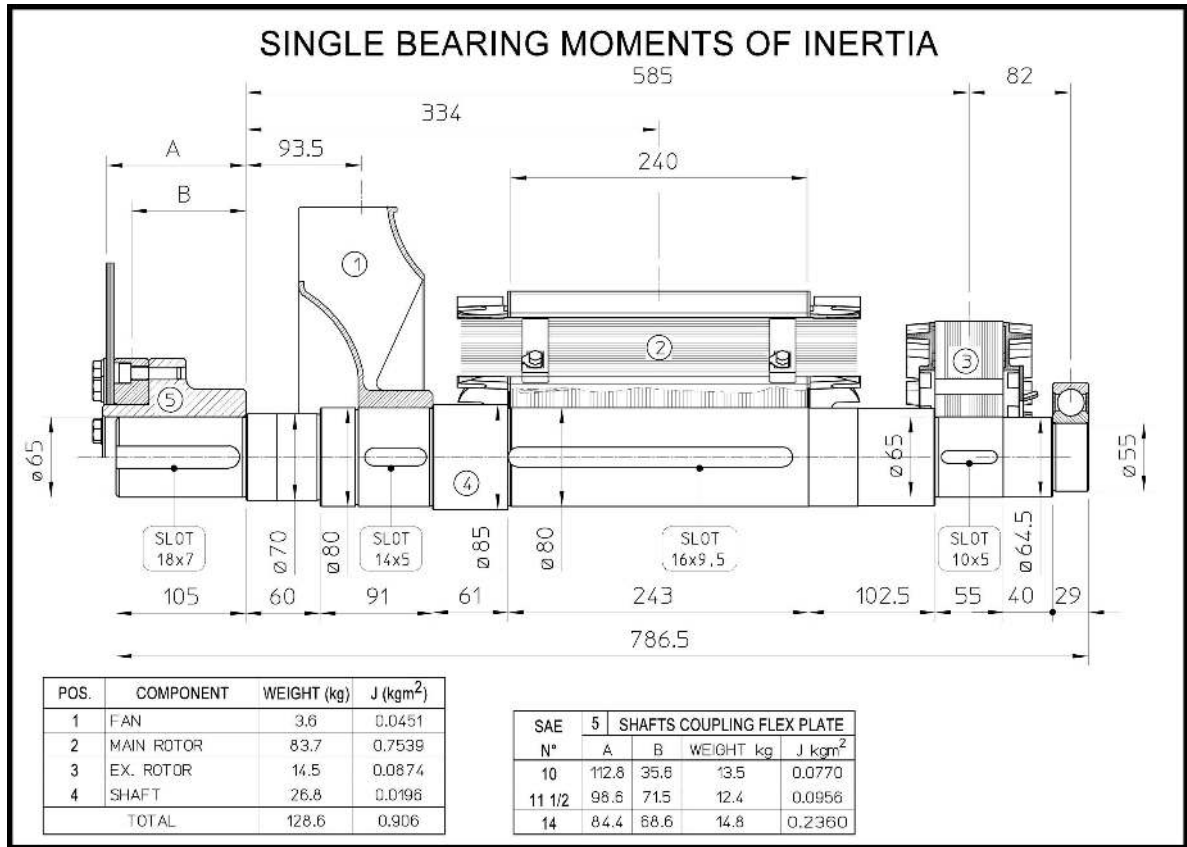

ECP34 1L4 A

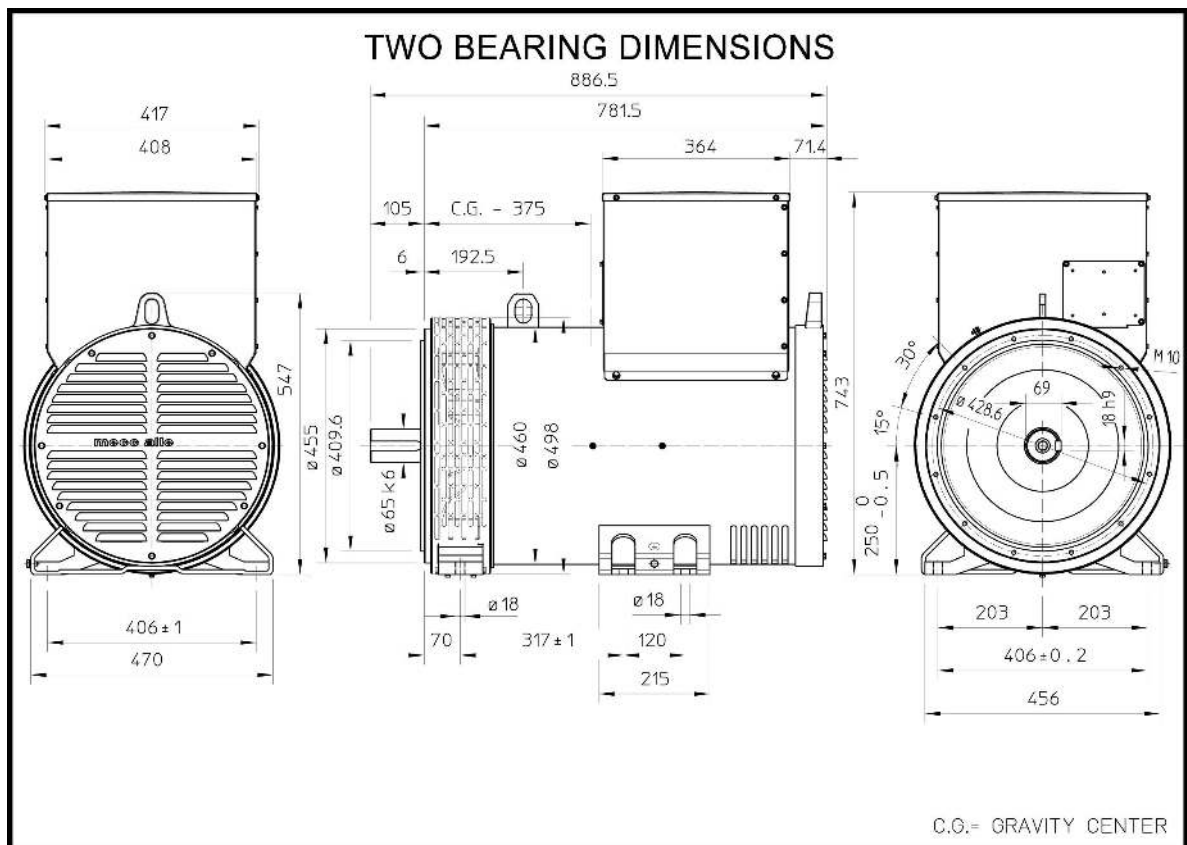
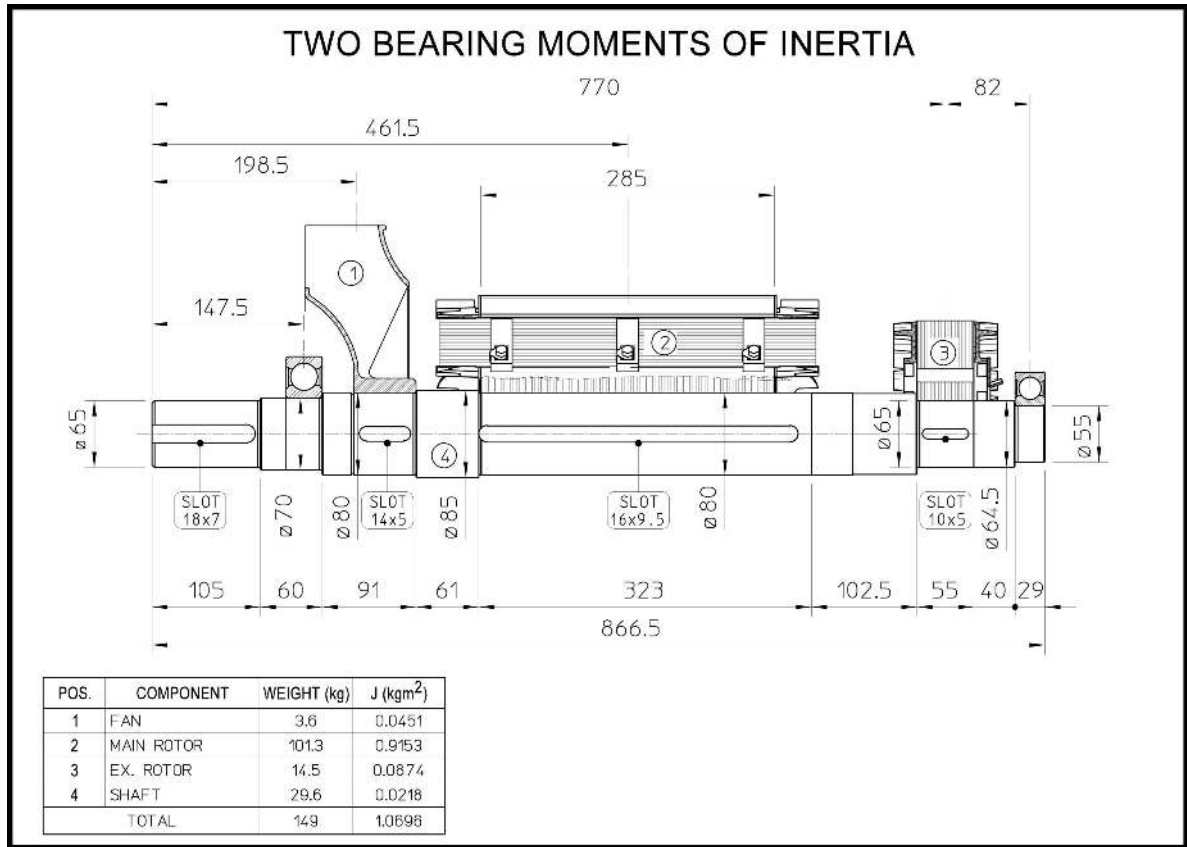

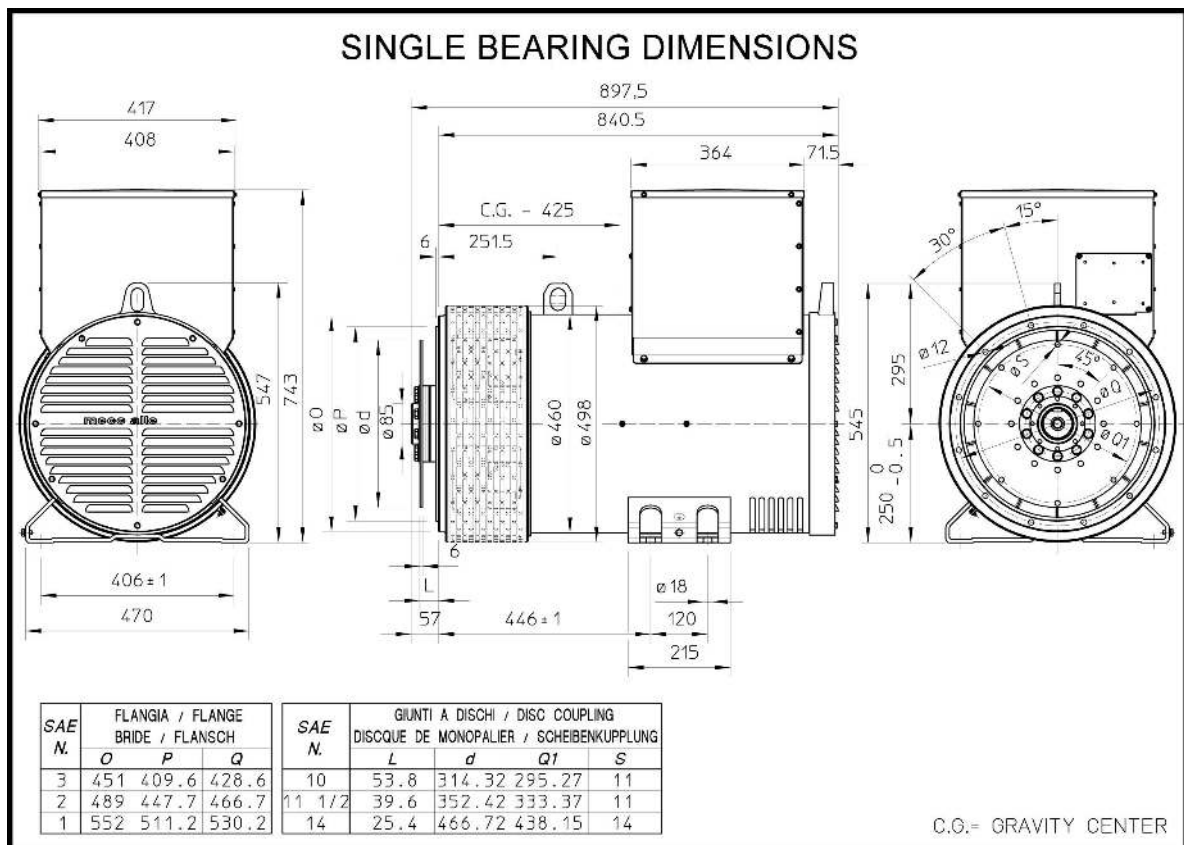
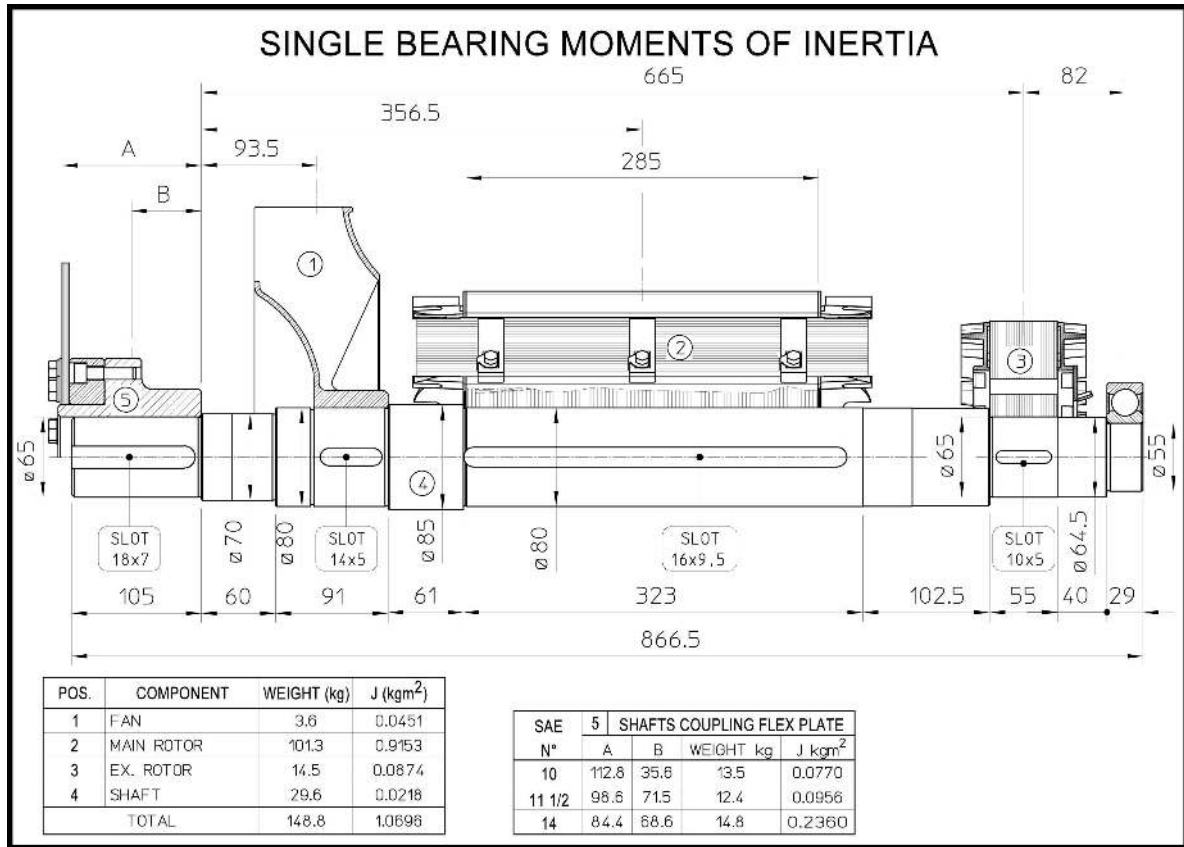

ECP34 2L4 A

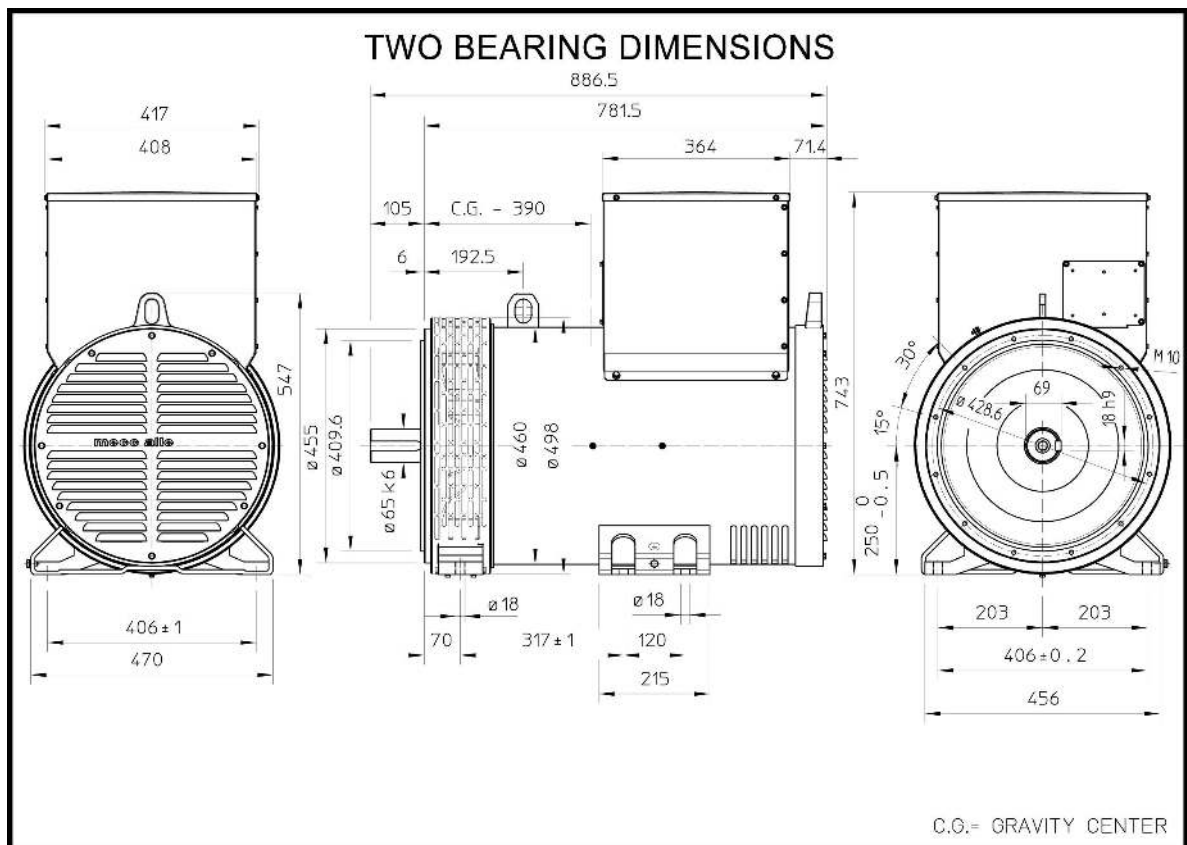
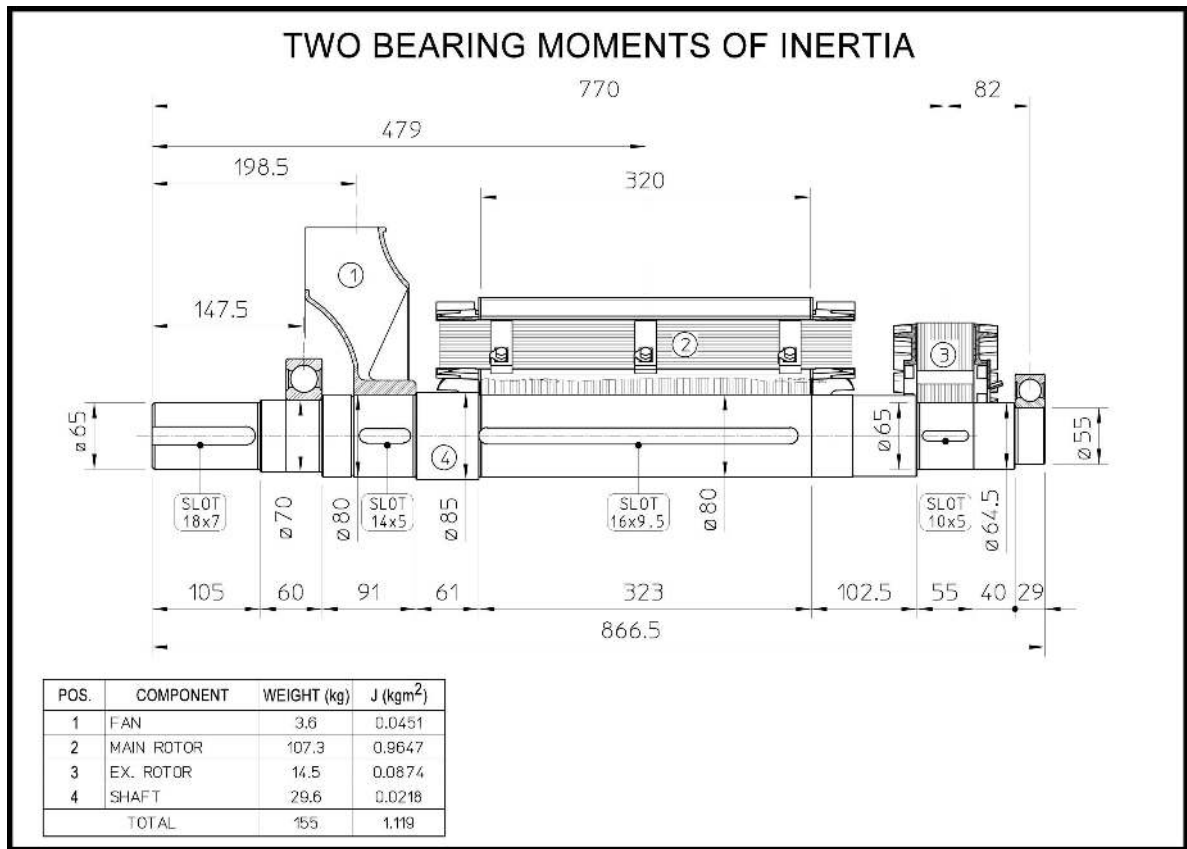

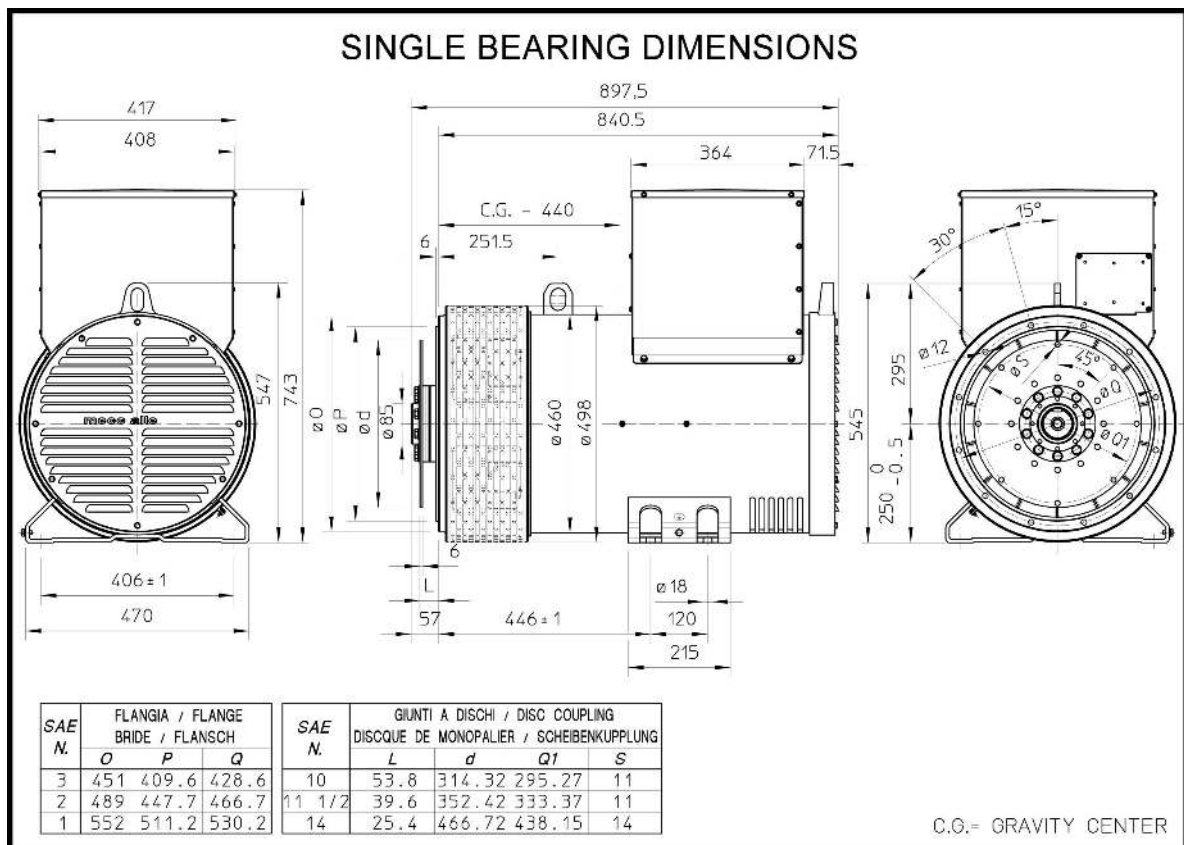
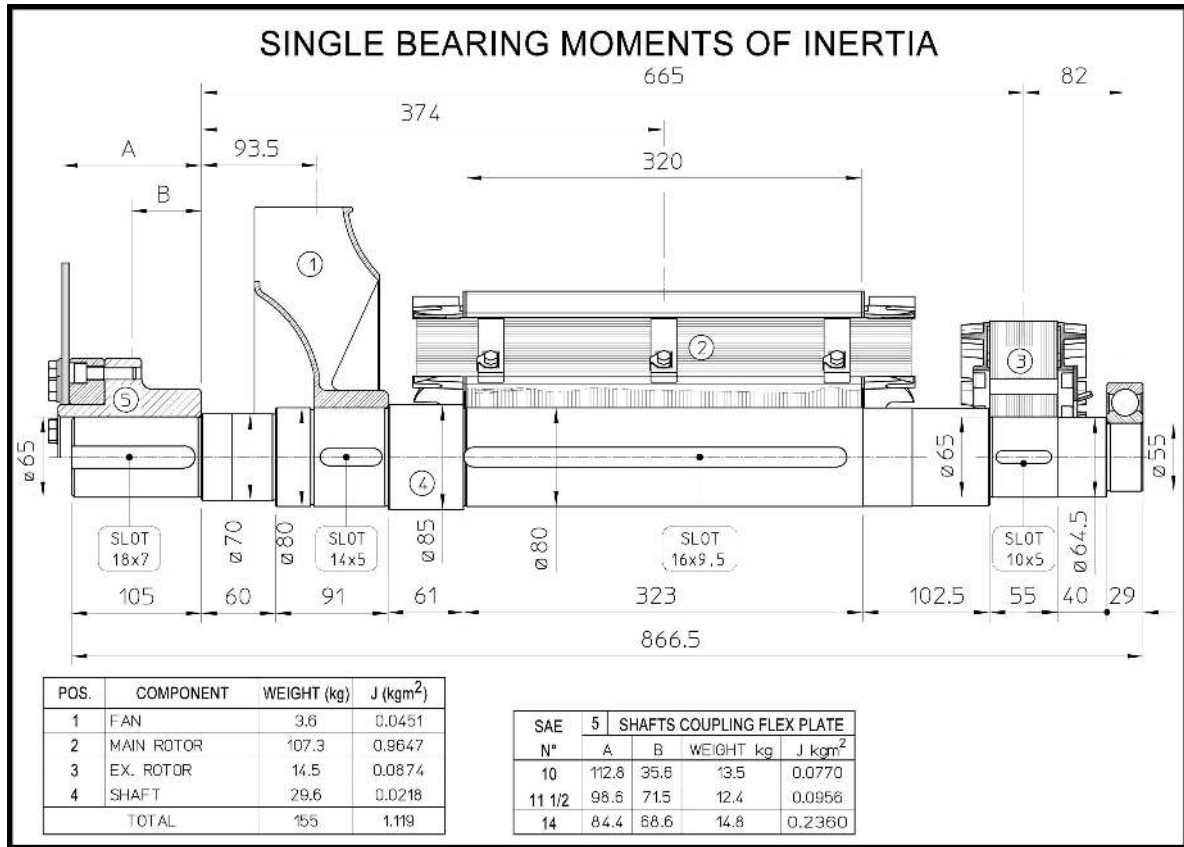

ECP34 3L4 A

