



Low-voltage asynchronous motors

Three-phase roller table motors
with squirrel-cage rotor
for mains and converter-fed operation

SENSE EXPERIENCE
EXPERIENCE VISION



Low-voltage asynchronous motors

Three-phase roller table motors
with squirrel-cage rotor
for mains and converter-fed operation

Contents

Introduction	5	1
Technical explanations	12	
Heavy-duty roller table motors, series ARB, ARC	31	2
Welded steel three-phase asynchronous motors, series DS, DSf, DSo, DSWM	45	3
Light-duty roller table motors, series IE2-AE1R	49	4
Dimensions	55	5

The products featured in this catalogue are also presented in the VEM interactive electronic catalogue.

Further information about the company and the VEM product range can be found on the Internet at www.vem-group.com.

This online information assists you in your selection and configuration of a drive solution and incorporates functions to print out data sheets and product enquiries. In addition, scale and dimensioned product drawings can be displayed or exported in various 2D and 3D formats.

Alongside general information about the VEM group, direct access is provided to catalogues, spare parts lists, operating manuals and maintenance instructions for the individual product groups.

Note:

We are at all times committed to constant further improvement of our products. Design details, technical data and illustrations are thus subject to change and may only be deemed binding after written confirmation by the manufacturer.



Introduction
Technical explanations

Introduction

VEM is an innovative, dependable and internationally recognised manufacturer of technically sophisticated system and drive solutions, as well as special drives and individual components. The product range covers practically the complete spectrum of electric motors and drives for industrial use. Through many years of experience in three-phase drive design, manufacturing, assembly and project development, VEM has gathered a wealth of know-how in

many special fields of application. One of these fields is the steel and rolling mill industry, with its extremely challenging demands and operating conditions. VEM has developed a full, complex package of drive solutions tailored to the specific requirements of this sector. This package includes not only "classic" roller table motors, but also geared table motors in numerous versions and "special motors" for particular applications in the rolling mill industry.

Series	Light-duty VEM roller table motors				Heavy-duty VEM roller table motors			
	(Ex-)A..R	(Ex-)A..F	(Ex-)A..O	(Ex-)A..B	ARB	ARC	DS..	
Type of cooling	IC 411 Self-ventilated	IC 416 Forced-ventilated	IC 410 Non-ventilated	IC 31 W Water-cooled	IC 410 Non-ventilated	IC 410 Non-ventilated	IC 410, IC 411, IC 416, 31 W –	
Power supply	Mains or converter-fed				Mains	Converter-fed	Mains or converter-fed	
Sizes	63 ... 400		63 ... 400	225 ... 280	280 ... 400	22, 33, 54, 65	112 ... 400	355 ... 630
Efficiency class to EN 60034-30	without, IE1, IE2 or IE3				without	without	without	
Output range [kW]	0.06 ... 710		0.06 ... 235	37 ... 90	110 ... 710	0.4 ... 5.5	1.1 ... 290	100 ... 1500
Duty types	S1, S3, S6, S7, S9				S4	S3, S6, S7, S9	S1, S3, S6, S7, S9	
Rated torque [Nm]	1 ... 4550		0.3 ... 1515	240 ... 600	700 ... 4550	2.5 ... 35	10 ... 2500	1000 ... 15000
Acceleration torque [Nm]	1.6 ... 7000		0.5 ... 2700	490 ... 1000	1260 ... 8200	22 ... 240	45 ... 7500	1000 ... 25000
Housing material	EN-GJL-200, optionally EN-GJS 500			Sheet steel	EN-GJL-200	EN-GJL-200 optionally EN-GJS 500	Sheet steel	
Housing type	Ribbed (horizontal/vertical)		Smooth surface		Ring-ribbed		Smooth/ribbed	
Thermal class	Thermal class 155, optionally 155 (F(B)), 180							
Transponder	Optional RFID system iID@2000 (13.56 MHz based on ISO 15693), (size A42. 400 as standard)							

Light-duty roller table motors, series AE.R, AE.O, AE.F for mains and converter-fed operation

Output range	0.09 – approx. 710 kW
Type of protection	IP 55 to DIN EN 60034-5, higher protection ratings as an option
Types of cooling	IC 410, IC 411, IC 416 and water-jacket cooling to DIN EN 60034-6
Construction types	IM B3, IM B35, IM B5 and derived types to DIN EN 60034-7

The series AE1R (IC 411), AE1O (IC410) and AE1F (IC 416) are derived from the VEM standard motor series and are mechanically identical in their principle design elements. The motor windings have been adapted to the particular

application of roller table drive. All screwed connections are additionally secured and the corrosion protection is similarly adapted for use in rolling mills.

Heavy-duty roller table motors, series ARC for converter-fed operation

Sizes	112 – 400
Output range	0.4 – approx. 240 kW
Type of protection	IP 55 to DIN EN 60034-5, higher protection ratings as an option
Types of cooling	IC 410, IC 411, IC 416 and water-jacket cooling to DIN EN 60034-6
Construction types	IM B3, IM B35, IM B5 and derived types to DIN EN 60034-7

The series ARC (IC 410) is designed for converter-fed operation in rolling mill applications. It represents a combination of the positive features of a converter-fed double squirrel-cage rotor, with its torque characteristic geared to optimum acceleration (MK/MB approx. 3), and the mechanically

robust construction of a heavy-duty roller table motor. The overall design is identical to that of a VEM standard motor, with the exception of the housing form (circumferential ribs) and the bearing/seal arrangement on the D end.

Heavy-duty roller table motors, series ARB for mains operation

Sizes	22 (132), 33 (125), 54 (180), 65 (200)
Output range	0.4 – 5.5 kW
Type of protection	IP 55 to DIN EN 60034-5, higher protection ratings as an option
Type of cooling	IC 410 to DIN EN 60034-6
Construction types	IM B3, IM B35, IM B5 and derived types to DIN EN 60034-7

The heavy-duty roller table motor ARB (IC 410) is designed for mains operation. As with the ARC series, the housing is provided with circumferential cooling ribs. It is manufac-

ured from grey-cast iron with ribs running transverse to the shaft direction. The conventional motor design achieves a soft torque characteristic and long blocking times.

Transnorm motors, series DS, DSf, DSo, DSWM for mains and converter-fed operation

Sizes	355 – 630
Output range	100 – approx. 1400 kW
Type of protection	IP 55 to DIN EN 60034-5, higher protection ratings as an option
Types of cooling	IC 410, IC 411, IC 416 and water-jacket cooling to DIN EN 60034-6
Construction types	IM B3, IM B35, IM B5 and derived types to DIN EN 60034-7

Robust to meet the toughest demands

The motors are designed as welded steel constructions and can be adapted to specific project demands. The drive elements of the mill and driving tables in rolling mills are subjected to particularly exacting electrical and mechanical demands. They must cope with a diversity of operating modes, such as continuous, intermittent and short-time duty, as well as start-up, braking and reversing functions. Furthermore, the motors must withstand the high ambient temperatures arising from the molten steel and the overloads which may occur if jammed stock blocks the transport system. Exposure to water must frequently be expected, and this must be taken into account by the mechanical design of the motor. VEM roller table motors are ideally prepared to handle all such extreme operating conditions.



Fig. 1: Wide hot strip mill train, ARC 315

Proven quality – modern design

VEM roller table motors of the classic series ARB 22 – 65 have been demonstrating their function capabilities and reliability under often extreme ambient conditions for many decades.

On the basis of this experience, VEM has developed several variants of roller table motors, which are each adapted to the special requirements of modern drive technologies for use in conjunction with a frequency converter. The motor windings are designed specifically for converter-fed operation. In contrast to a classic roller table motor design with soft torque characteristic and long blocking times, roller table motors for converter-fed operation feature a specially tailored characteristic, as is typical for a double squirrel-cage rotor. This ensures reliable synchronous operation with grouped drives, even under changing loads, which in turn is a prerequisite for high rolling quality.



Fig. 2: Motor of the ARB series for mains operation



Fig. 3: Motor of the ARC series with built-on holding brake and incremental encoder

Versatile applications – individual adaptation

With regard to their mechanical design, the motors are available either as robust grey-cast constructions with horizontal/vertical ribbing, in versions with self- or forced ventilation as series IE2-AE.R/AE.F or in a non-ventilated version as series IE2-AE10, or else on the basis of a ring-ribbed housing in the case of series ARC and ARB.

In converter-fed operation, the operating speeds can be matched perfectly to the individual drive requirements. As control is realised primarily in the lower frequency range, project-specific adaptation of the windings and the use of a frequency converter with automatic voltage boost or field-oriented control are recommended. The windings are designed specifically for converter-fed operation. Detailed operating data sheets are available to assist project planning. They are based on windings for thermal class 155. Designs for thermal class 180 are also possible as an option, for example as a means to increase the frequency of switching operations.

For existing installations, it is still possible to choose the heavy-duty series ARB, which is designed specifically for mains operation and can withstand a blocking period of several minutes without damage (soft torque characteristic, additional heat sinks on the rotor).



Fig. 4: Furnace table with ARG 200L 12, $M_{\max}=1888$ Nm

Geared roller table motor version

The single- and multi-stage gearing arrangements used by VEM motors GmbH are developed in cooperation with leading gear manufacturers and designed specifically for operation in continuous casting, furnace and rolling mill plant.

All individual components meet the tough demands posed by such environments. The gear housings are manufactured as grey cast iron (GG), spheroidal cast iron (GGG) or welded steel constructions, depending on the motor type and version. The dimensioning of the wall thickness ensures that ample space is available for the bearings and seals required at a particular place of installation. The actual gears are likewise matched in their dimensions to the individual demands. The gear teeth are designed as corrected involute helical teeth and have been case-hardened and honed. The quality complies with the stipulations of DIN quality class 7. The material used is 16MnCr5, 20MnCr5 or 17CrNiMo6. The drive shaft is sealed to the outside with a VITON sealing ring running on a hardened and ground bushing and with an additional labyrinth seal in order to prevent the penetration of dust, scale or water. The gearing is oil-lubricated (immersion lubrication). For special applications, for example in continuous casting plant (high ambient temperatures), we recommend lubrication with synthetic oils. In certain cases, fluid grease may be sufficient.

The torques specified in the data sheet are firstly the nominal torque and secondly the acceleration or breakdown torque. The breakdown torque generally lies 20 – 30% above the acceleration torque. The nominal torque can be delivered 24 hours a day without influencing service life. The acceleration torque can occur for a duration of 5 seconds approx. 100 times per hour without influencing the service life of the gearing. The maximum loading of the gears is designed such that the acceleration torque can be exceeded by 2.5 times occasionally (also several times per day, but not more than 10 times per hour for 2 seconds in each case), without influencing the service life of the gearing. The gearing is durable at acceleration torque. The motors are integrated with the gearing by way of at least four bolts. They can thus be separated from the gearing



Fig. 5: Roller table version, SG200 ARG 200L 8, $M_{\max} = 1655$ Nm



Fig. 6: Delay table with S141-1A ARG 160L 4, $M_{\max}=1039$ Nm

at any time, for example for maintenance purposes. It is merely necessary to drain the oil from the gearing before separation. The motors always possess an oil-tight seal at the drive end. The bearing on the non-drive end is generally provided with lifetime lubrication.

VEM – your competent partner for drive questions

Wherever our customers need electric machines, we are at hand as a partner and offer every necessary support at all phases of a project. It is not important whether you are doing business in Europe, the Middle East, Asia or America. As the VEM market share increases also outside Germany, we are also expanding our sales network with a combina-

tion of own subsidiary companies and strategic alliances. Already today, our customers can address their questions to competent and experienced local partners all over the world. The dense network of sales and service contacts comprises agents and representatives in more than 40 countries.

Standards and regulations

The motors comply with all relevant standards and regulations, in particular with the following:

Title	International IEC	Europe EN
Rotating electrical machines. Rating and performance	IEC 60034-1	EN 60034-1
Methods for determining losses and efficiency of rotating electrical machinery from tests	IEC 60034-2-1	EN 60034-2-1
Efficiency classes of single-speed, three-phase, cage-induction motors	IEC 60034-30	EN 60034-30
Degrees of protection provided by the integral design of rotating electrical machines (IP code) – Classification	IEC 60034-5	EN 60034-5
Methods of cooling (IC code)	IEC 60034-6	EN 60034-6
Classification of types of construction, mounting arrangements and terminal box position (IM code)	IEC 60034-7	EN 60034-7
Terminal markings and direction of rotation	IEC 60034-8	EN 60034-8
Noise limits	IEC 60034-9	EN 60034-9
Starting performance of single-speed three-phase cage induction motors	IEC 60034-12	EN 60034-12
Mechanical vibration of certain machines with shaft heights 56 mm and higher – Measurement, evaluation and limits of vibration severity	IEC 60034-14	EN 60034-14
Balance quality requirements	ISO 1940	–
IEC standard voltages	IEC 60038	–
Electrical insulation – Thermal evaluation and designation	IEC 60085	–
General purpose three-phase induction motors	IEC 60072-1	EN 50347

VEM motors comply furthermore with various foreign regulations which are either based on IEC 60034-1 or else transpose the latter's stipulations as European standard EN 60034-1.

The following temperature-rise limits apply in conjunction with the aforementioned standards and regulations:

Regulation	Cooling air temperature	Permissible temperature-rise limit in K (measured by resistance method)				
		105 [A]	120 [E]	130 [B]	155 [F]	14,80 [H]
Thermal class acc. to EN 62114	°C					
EN 60034-1	40	60	75	80	105	125
IEC 60034-1	40	60	75	80	105	125
Great Britain	40	60	75	80	105	125
Italy	40	60	70	80	105	125
Sweden	40	60	70	80	105	125
Norway	40	60	-	80	105	125
Belgium	40	60	75	80	105	125
France	40	60	75	80	105	125
Switzerland	40	60	75	80	105	125

Efficiency classification (IE code)

Over the past few years, the worldwide developments relating to energy-saving motors have produced a multitude of country-specific regulations, laws and standards, which makes it difficult to properly compare individual products. The new IEC/EN standard 60034-30 is thus intended to establish a global common basis. In Europe, the standard supersedes the previous "Voluntary Agreement of CEMEP". Its scope has at the same time been extended to cover an output range from 0.75 kW to 375 kW, not only for 2- and 4-pole motors, but now also to 6-pole versions. The forthcoming second edition of IEC/EN 60034-30 will broaden the scope yet again. When it comes into force, the regulations will in future apply across an output range from 0.12 kW to 1000 kW, and will additionally include 8-pole

motors in the classification. The relevant ambient conditions are likewise to be extended significantly. The stipulations will then apply for a temperature range from -30 °C to + 60 °C, and for altitudes up to 4000 metres above sea level. Following the convention used to designate types of protection (IP = International Protection), the efficiency classes are indicated by the letters IE, standing for International Efficiency:

IE1	Standard Efficiency (former class EFF2)
IE2	High Efficiency (former class EFF1)
IE3	Premium Efficiency
IE4	Super Premium Efficiency

Efficiency determination

Parallel to the introduction of the new efficiency classes, the standard describing methods for the determination of efficiency has also been amended. In accordance with IEC/EN 60034-2-1, the additional losses are no longer simply assumed to be 0.5% of the power input, but instead determined in the manner of IEEE 112. The losses determined in this way vary with the motor power and lie between 3.5% (low power) and 0.5% of the power input. Consequently, the nominal efficiency may be reduced, even

though no actual changes have been made to the motors themselves.

Previously: $P_{LL} = 0.5\%$ of input power P
Now: $P_{LL} =$ individual measurement

P_{LL} = load-dependent additional losses

The following tables shows corresponding examples:

Example (EFF1, IE2) P / motor type	Loss determination method acc. to EN/IEC 60034-2:1996, 50 Hz	Loss determination method acc. to IEC 60034-2-1:2007, 50 Hz
5.5 kW, 2-polig	89.2 %	88.7 %
55 kW, 2-polig	94.5 %	93.2 %
5.5 kW, 4-polig	89.6 %	89.9 %
55 kW, 4-polig	95.0 %	94.0 %
5.5 kW, 6-polig	87.5 %	86.1 %
55 kW, 6-polig	95.2 %	93.5 %

The new limit values have been adapted to this method. IEC/EN 60034-2-1 replaced the previously used IEC/EN 60034-2 with effect from November 2010. As a formal conversion of test results to the new measuring method is not possible, the

new stipulations are being introduced in stages. IE-classified motors are always assessed according to IEC/EN 60034-2-1. In the case of motors without classification, the efficiency specifications are in part still based on EN 60034-2.

Notes on application of IEC/EN 60034-30 and Commission Regulation (EC) No. 640/2009

With Commission Regulation (EC) No. 640/2009 of 22nd July 2009, which serves to implement European Directive 2005/32/EC, minimum efficiency classes (Minimum Efficiency Performance Requirements, MEPS) are now stipulated on the basis of EN 60034-30:2009 and are to be gradually introduced in the market for certain types of electric motor:

Which motors are covered by EN 60034-30:2009?

Single-speed three-phase asynchronous motors with squirrel-cage rotor for 50 Hz and/or 60 Hz which are designed

- with a rated voltage U_N up to 1000 V;
- with a rated output P_N between 0.75 kW and 375 kW;
- with 2, 4 or 6 poles;

- for duty types S1 (continuous duty) or S3 (intermittent periodic duty) with a cyclic duration factor of 80% or more;
- for direct starting on the mains;
- for rated operating conditions in accordance with EN 60034-1, section 6.

Which motors are excluded from IE classification by EN 60034-30:2009?

- Motors which are designed specifically for converter-fed operation in accordance with IEC 60034-25;
- Motors which are fully integrated into a machine (e.g. pumps, fans and compressors) and cannot be tested separately.

Which motors are not covered by Commission Regulation (EC) No. 640/2009?

- a) Motors which are designed to be operated wholly immersed in a liquid;
- b) Motors which are fully integrated into a product (e.g. a gearbox, pump, fan or compressor) such that the energy efficiency cannot be determined separately from the product;
- c) Motors which are designed specifically for operation under the following conditions:
 - i) Altitude more than 1000 metres above sea level;
 - ii) Ambient temperatures above 40 °C;
 - iii) Maximum operating temperatures above 400 °C;
 - iv) Ambient temperatures below -15 °C (any motor) or below 0 °C (water-cooled motor);
 - v) Coolant temperatures below 5 °C or above 25 °C at the inlet to a product;
 - vi) Potentially explosive atmospheres in the sense of Directive 94/9/EC
- d) Brake motors

Amendments in Commission Regulation (EU) No. 4/2014 of 6th January 2014

- Altitude above 1000 metres, now 4000 metres
- Ambient temperatures above 40 °C, now 60 °C
- Ambient temperatures below -15 °C, now -30 °C, or below 0 °C for water-cooled motors
- Coolant temperatures below 5 °C, now 0 °C, and above 25 °C, now 32 °C.

These changes become effective from 27th July 2014.

Which deadlines apply for the introduction of minimum efficiency

Stage 1: Minimum efficiency class IE2 since 16th June 2011

Stage 2: Tightening to IE3 [Premium Efficiency] with effect from 1st January 2015 for the output range 7.5 kW to 375 kW. Optional possibility: "IE2 + converter".

Stage 3: Extension of output range to between 0.75 kW and 375 kW with effect from 1st January 2017. The optional possibility "IE2 + converter" remains applicable.

The manufacturer guarantees to the customer by way of CE marking that the required nominal efficiency is attained and that the rated efficiency specified on the rating plate is observed.

The permissible tolerances specified in DIN EN 60034-1 continue to apply.

New requirements for documentation (excerpt from Reg. (EC) No. 640/2009)

From 16th June 2011, the information set out points 1 to 12 is to be displayed visibly:

- a) in the technical documentation of motors;
- b) in the technical documentation of products into which motors are incorporated;
- c) on freely accessible websites of the manufacturers of motors;
- d) on freely accessible websites of the manufacturers of products into which motors are incorporated.

In the technical documentation, the information must be provided in the order as presented in points 1 to 12. It is not imperative to use the exact wording used in the list. The information may also be presented using graphs, diagrams and symbols.

1. Nominal efficiency (η) at 100%, 75% and 50% of the rated load and voltage (U_N);
2. Efficiency level: "IE2" or "IE3";
3. Year of manufacture;
4. Manufacturer's name or trademark, commercial registration number and place of business;

5. Product model number;
6. Number of poles of the motor;
7. Rated power output(s) or range of rated power output [kW];
8. Rated input frequency(-ies) of the motor (Hz);
9. Rated voltage(s) or range of rated voltage [V];
10. Rated speed(s) or range of rated speed [rpm];
11. Information relevant for disassembly, recycling or disposal at the end-of-life of the product
12. Information on the range of operating conditions for which the motor is specifically designed:
 - (i) altitudes above sea level;
 - (ii) ambient air temperatures, also for motors with air cooling;
 - (iii) water coolant temperature at the inlet to the product;
 - (iv) maximum operating temperature;
 - (v) potentially explosive atmospheres.

Since 16th June 2011, it is no longer permissible to bring non-classified or IE1 standard motors onto the market in the EU.

Type designation

The type designation comprises 7 basic parts + a code for special versions, namely

- the energy efficiency class,
- the motor version,
- the series code,
- the type of cooling,
- the size/shaft height,
- the foot length and a supplementary code for output definition
- the number of poles, and
- the special version code,

which are strung together to form a complete motor designation. It is not imperative for each of the 8 elements to be present. In the following, the individual elements are explained together with their possible combinations. Deviations from the type designation are only permissible for certified series, for example CSA-certified motors are only available as K11R.

The type code is valid for newly determined ID numbers from the date of publication.

IE2	-	A	E	1	R	160	M	X	2	IL	...	HW
1		2	3		4	5	6		7	8	...	9

1. Energy efficiency class

	Designation	Standard
(none)	Not classified	-
IE2	High Efficiency	IEC/EN 60034-30
IE3	Premium Efficiency	IEC/EN 60034-30

2. Motor version

	Designation
A	Roller table motor
B	Brake motor (squirrel-cage rotor)
DS	Three-phase transnorm motor as welded steel construction

3. Series

	Designation
	Not specified in case of three-phase transnorm motors as welded steel construction
E1	Energy-saving series with efficiency class IE2, design generation 1
E2	Energy-saving series with efficiency class IE2, design generation 2 (all sizes/numbers of poles)
RB	In combination with 2 nd code element A: Roller table motor for mains operation, type of cooling IC 410, 4 th code element not applicable
RC	Ring-ribbed housing In combination with 2 nd code element A: Roller table motor for converter-fed operation, type of cooling IC 410, 4 th code element not applicable
RG	Ring-ribbed housing In combination with 2 nd code element A: Geared roller motor for converter-fed operation, type of cooling IC 410

4. Type of cooling

4.1 Standard series

	Designation	Type of cooling
B	Water cooling	IC 71W, (IC 31W)
WM	Water jacket cooling for three-phase transnorm motors as welded steel construction	
F	Rib cooling with built-on forced-ventilation fan	IC 416
f	Rib cooling with built-on forced-ventilation fan for three-phase transnorm motors as welded steel construction	
O	Rib cooling without own fan	IC 410
o	Rib cooling without own fan for three-phase transnorm motors as welded steel construction	
R	Rib cooling with own fan	IC 411

5. Size

63, 71, 80, 90, 100, 112, 132, 160, 180, 200, 225, 250, 280, 315, 355, 400, 450, 500, 560, 630
ARB: 22 (132), 33 (125), 54 (170) and 65 (200) – Figures in brackets: Shaft height in mm

6. Foot length/supplementary code for output definition

Foot length	Designation	Supplementary code	Designation
S	short	X	Higher output in case of two outputs/foot length
M	medium	Y	Reduced output ¹⁾
L	long	Z	Higher output in case of three outputs/foot length

¹⁾ increased output for size 315

7. Number of poles

2p=	Synchronous speed n (at 50 Hz) [rpm]
2	3000
4	1500
6	1000
8	750
10	600
12	500
16	375
20	300
24	250

Hyphen as separator in case of pole-switching motors, descending number of poles

Codes for special versions

TWH	Thermal winding protection with NTC thermistor
TPM	Thermal winding protection with PTC thermistor
WE	Special shaft
....

For further details, see overview of modifications

Name plate

In the normal standard version, the motor name plate displays information in the German and English languages. Other languages are possible, though an extra charge must be made for non-EU languages.

The name plate displays the most important rating data, such as the type designation and motor number, output, rated voltage and frequency, rated current, type of construction, type of protection, power factor, speed and thermal class.

The scope of information may vary according to motor type. In the case of motors with relubrication system, the relubrication interval and the grease amount per lubrication cycle are also specified either on the name plate itself or on an additional plate. Name plates are attached to the housing using grooved pins such that they are permanently secure. They can be made of aluminium or stainless steel (extra charge).

Consultation is necessary if additional plates are required.

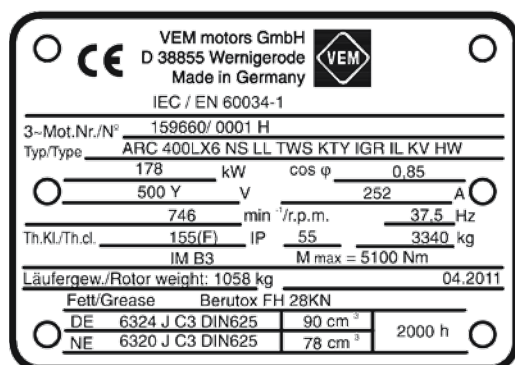

Fig. 7: Example of a name plate for roller table motors

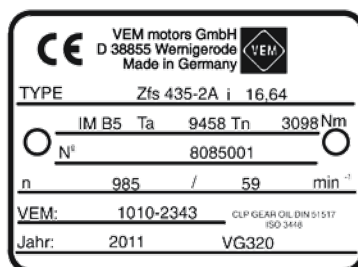
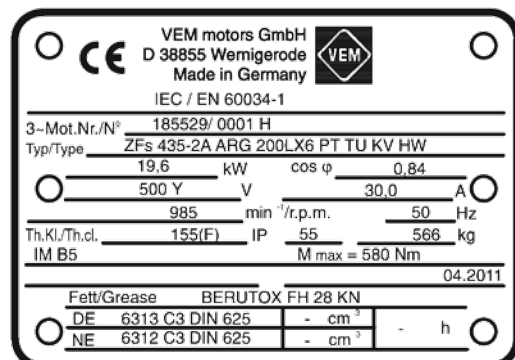

Fig. 8: Example of a name plate for geared roller table motors

Cooling and ventilation

Roller table motors of the heavy-duty series ARB and ARC are designed without ventilation fans for type of cooling IC 410.

Light-duty roller table motors of series AE.R are fitted with radial fans made from plastic or cast aluminium alloy, which provide cooling independently of the running direction of the motor (IC 411 to EN 60034-6). For noise reasons, 2-pole

motors with shaft height 355 can only be supplied with low-noise, direction-dependent fans. When installing the motors, a minimum clearance between the fan hood and the wall (dimension B1) must be observed to ensure correct cooling. The fan hood is always manufactured in sheet steel. This series can also be supplied without ventilation (AE.O...) or with forced ventilation (AE.F ...) as an option.

Design versions

The housings of the light-duty series AE.O possess horizontal/vertical ribbing, those of the heavy-duty series ARB, ARC cooling ribs transverse to the shaft direction. Both housing designs are characterised by their high mechanical strength and very good thermal capacity. The terminal box for motors of the series AE.O can be mounted either

at the top, on the right or on the left, as is the case for the standard motor series K21R, K20R. The terminal box for series ARB is mounted on the right, while that for series ARC is positioned either on the top at the non-drive end or optionally on the non-drive-end shield.

Shaft height	Series	Housing	Material for bearing end shields	Feet	Foot mounting
132 to 280 315	AE1R AE1O AE1F	Grey cast iron	Grey cast iron	Grey cast iron	Bolted
355, 400	AE2R, AE2O, AE2F				Cast-on
112 to 400	ARC				Cast-on
22 to 65	ARB				Cast-on
355 to 630	DS, DSf, DSo, DSWM	Steel	Steel	Steel	Welded

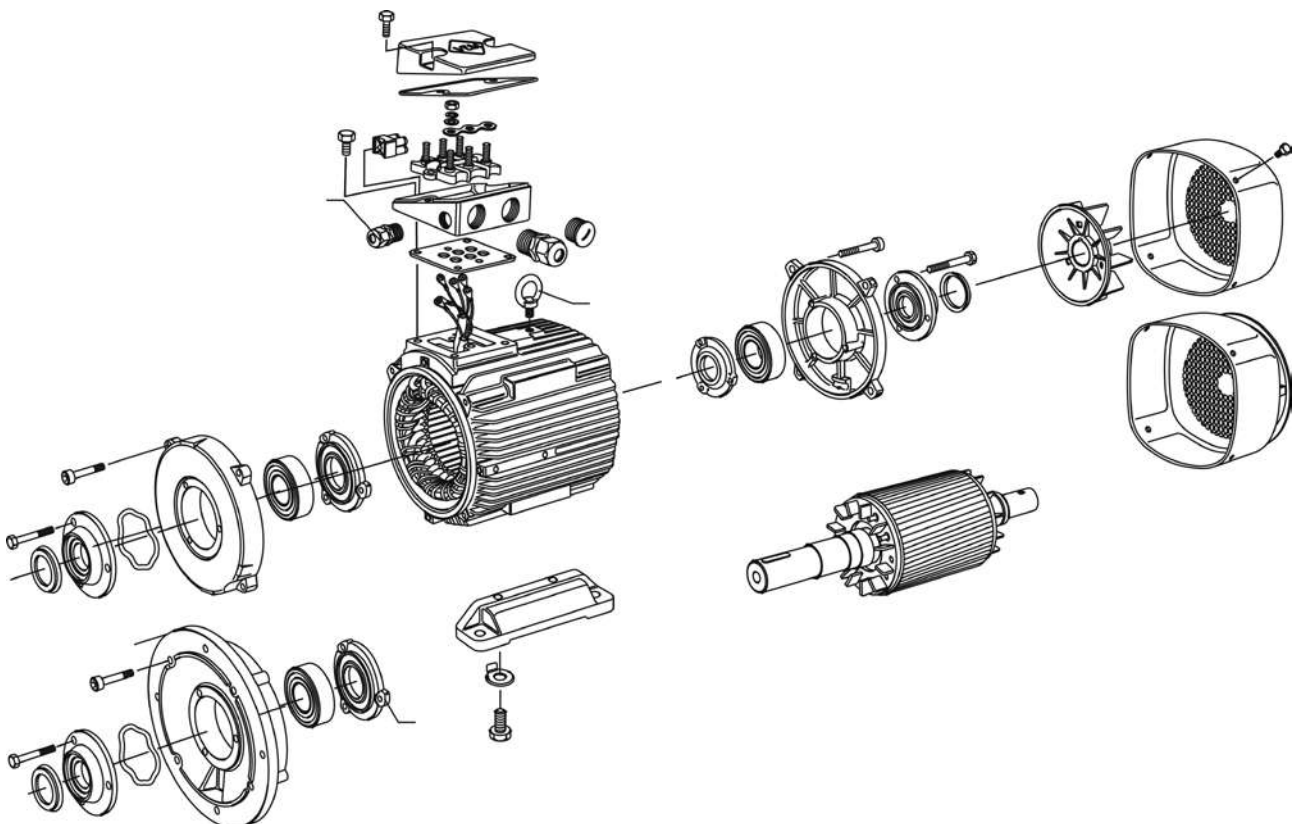

Fig. 9: Design of an IE2-AE.R motor, schematic representation

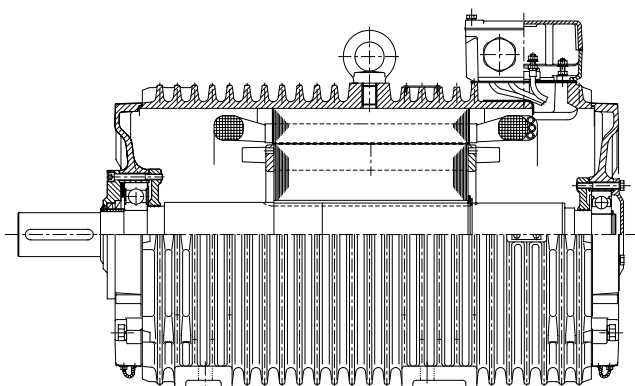

Fig. 10: Design example for series ARC, with top-mounted terminal box

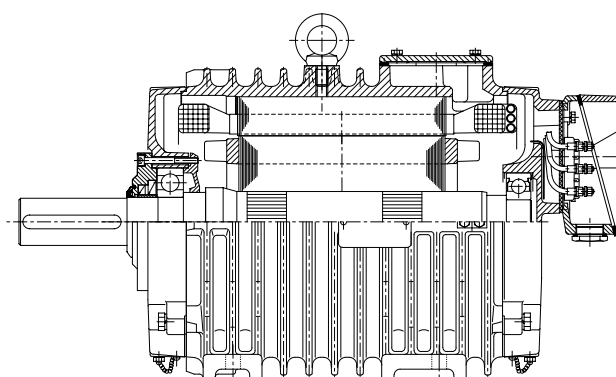

Fig. 11: Design example for series ARC, terminal box on non-drive-end shield

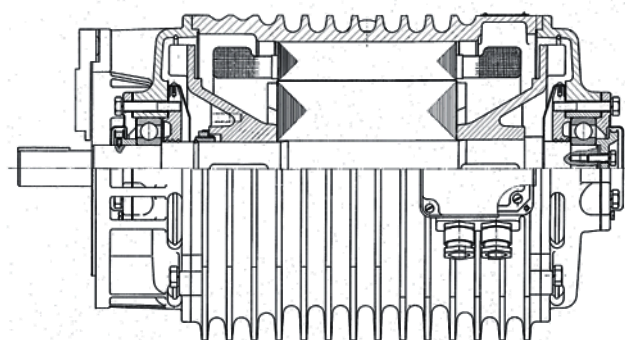
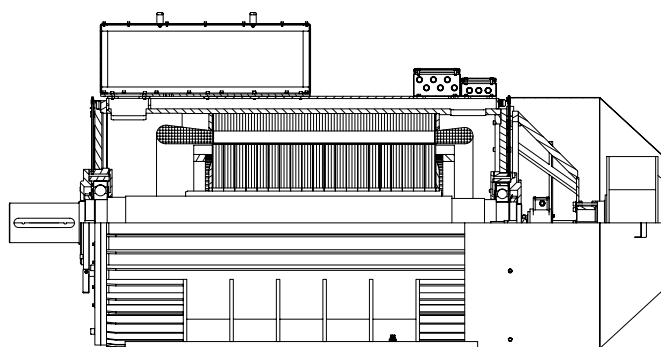
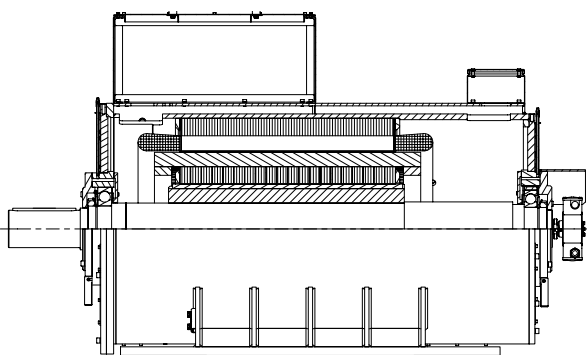

Fig. 12: Design example for series ARB, terminal box mounted on the right



Design examples for welded-steel transnorm motors, types of cooling IC 411 and IC 416

1

Type of protection

The motors possess condensation drain holes in their end shields (by request only for shaft heights up to 132 T). These holes are closed with plastic plugs.

In case of motors with a shaft end pointing upwards, the user must take appropriate precautions to prevent the penetration of water along the shaft.

On flange motors of construction types IM V3 / IM V36, a drain hole is provided as standard to prevent the collecting of liquid in the flange end. Where motors are

to be used or stored outdoors, a corresponding roof or additional covers are recommended in order to avoid long-term exposure to direct sunlight, rain, snow and dust, and to eliminate the risk of the fan freezing up due to direct snowfall or icing. In such cases, it is recommended to consult the manufacturer for technical clarification. The use of non-rusting bolts and screws (option) is recommended if the motor is to be used outdoors or in a corrosive environment. Any deviating ambient conditions are specified on the motor name plate. The specifications on the name plate shall then apply.

Types of construction

The most common types of construction are shown in the list below. Further types of construction can be supplied upon request. The type of construction is indicated on the name plate in accordance with Code I, EN 60034-7. Standard motors which are ordered in a basic type in sizes 56 to 200 can also be operated with the following derived types of construction.

- IM B3 in IM B5, IM B7, IM B8 and IM V6
- IM B35 in IM 2051, IM 2061, IM 2071 and IM V36
- IM B34 in IM 2151, IM 2161, IM 2171 and IM2131
- IM B5 in IM V3
- IM B14 in IM V19

Motors of types IM V5, IM V1 or IM V18 can be designed with an optional protective canopy to prevent small parts falling into the motor. With types of construction with the shaft end pointing upwards, it is the responsibility of the user to provide a suitable cover to prevent small parts falling into the fan shroud (see also standard IEC/EN 60079-0). The cooling air flow must not be hindered by the cover. From size 225, it is necessary to consult the manufacturer regarding types of construction IM V5, IM V6, IM B6, IM B7 and IM B8. The types of construction IM B5 and IM V3 are not available for frame sizes from 315 L. To facilitate connection to the mains power supply, the terminal box can be rotated by 90° with all types of construction (with the exception of motors with terminal box 630 or 1000, inclined – in these cases, the terminal box can only be rotated by 180°).

Vibration response and balancing

The permissible vibration severities for electric motors are specified in standard EN 60034-14. VEM motors already meet or remain below the limit values specified for vibration severity grade A (normal, with design-

ation on the name plate) in their basic versions. Vibration severity grade B (special code “SGB” in the type designation) can be supplied at extra charge.

EN 60034-14 recommends the following values:

Vibration severity grade	Shaft height H Machine installation	56 ≤ H ≤ 132			132 ≤ H ≤ 280			280 > H		
		s _{eff} [μm]	v _{eff} [mms ⁻¹]	a _{eff} [ms ²]	s _{eff} [μm]	v _{eff} [mms ⁻¹]	a _{eff} [ms ²]	s _{eff} [μm]	v _{eff} [mms ⁻¹]	a _{eff} [ms ²]
A	Free suspension	25	1.6	2.5	35	2.2	3.5	45	2.8	4.4
	Rigid mounting	21	1.3	2.0	29	1.8	2.8	37	2.3	3.6
B	Free suspension	11	0.7	1.1	18	1.1	1.7	29	1.8	2.8
	Rigid mounting	-	-	-	14	0.9	1.4	24	1.5	2.4

Grade A is applicable for machines with no special vibration requirements.

This grade is essentially equivalent to the old grade N in case of free suspension. For motors from size 250, the limit values are tightened from 3.5 mm/s to 2.8 mm/s. This corresponds to the former limit value for R at speeds > 1800 rpm.

Grade B is applicable for machines with special vibration requirements.

This grade is essentially equivalent to the old grade S in case of free suspension. The corner frequencies for vibration displacement/vibration velocity and vibration velocity/vibration acceleration are 10 Hz and 250 Hz, respectively. It must be noted that the measured values may deviate from the actual values by ± 10% due to the tolerances of the measuring devices.

With regard to the routine testing of machines with speeds between 600 and 3600 rpm, EN 60034-14 states that it is sufficient to measure the vibration velocity.

All rotors are balanced dynamically with a half-key in place. This balancing is documented on the name plate by way of the letter “H” after the motor number. Upon request, it is possible to perform balancing with a full key. This is subsequently indicated by the letter “F” after the motor number. In case of converter-fed operation with frequencies greater than 60 Hz, special balancing is required to observe the specified limit values (high-speed version, special code “HS” in the type designation).

Bearings

VEM motors are fitted with anti-friction bearings from leading manufacturers. The nominal service lifetime of the bearings is at least 10,000 hours for 2-pole motors or 20,000 hours for motors with 4 or more poles, assuming full exploitation of the maximum permissible load. The nominal service lifetime of the bearings for motors installed in a hori-

zontal position without additional axial load is 40,000 hours in coupled operation. Under average operating conditions, with loads below the maximum permissible load, a nominal service life L_{h10} of 10,000 hours can be achieved. Detailed specifications are to be found in the Main Catalogue.

Bearing monitoring

To permit monitoring of the condition of the bearings, motors can be fitted with or prepared for the fitting of temperature, shock pulse and vibration sensors. PT100-type temperature sensors can be mounted at the bearing points in 2-, 3- or 4-wire configurations. The sensors are connected at the main terminal box or else in a separate box mounted either on the main terminal box or on the motor housing, depending on the individual design.

For monitoring of the wear of the anti-friction bearings, shock pulse sensors [SPM] can be mounted on the end shields from size 132. This permits monitoring by way of mobile recording units. It is also possible to use hard-wired shock pulse or vibration sensors to enable remote monitoring.

Use of insulated bearings

When motors are operated on the mains, magnetic asymmetries result in a voltage along the shaft. This shaft voltage causes compensating currents to flow between the rotor and stator via the anti-friction bearings. If the voltage exceeds a threshold of 500 mV, the bearings may be damaged. The design of VEM standard motors ensures that this value can never be exceeded.

The effects may be intensified in case of converter-fed operation. The converter design is a decisive influencing factor. Pulse-controlled converters produce especially high-

frequency voltages and currents dependent on the pulse frequency and the pulse modulation. Output filters in the converter minimise these effects. To avoid bearing damage, motors for converter-fed operation from size 315 MY are always fitted with an insulated bearing on the non-drive end. In addition to this measure, it is always imperative to provide for proper earthing of the motor housing in order to drain the currents circulating between the converter and stator.

Shaft ends

IEC 60034-7 defines the two sides of a motor as follows:

D-end (DS): Drive side of the motor (drive end)
N-end (NS): Side of the motor opposite the drive (non-drive side)

Centre holes in accordance with DIN 332, sheets 1 and 2, form DS.

The keys and keyways are machined in accordance with DIN 6885 sheet 1, form A or B for frame sizes 56 – 112 and in accordance with DIN 6885 sheet 1, form A for frame sizes 132 – 355. The lengths of the keys comply with EN 50347 for shaft heights 132 – 355.

Threads for fitting and pulling fixtures

Shaft end diameter	Thread
from 7 to 10 mm	M3
from 10 to 13 mm	M4
from 13 to 16 mm	M5
from 16 to 21 mm	M6
from 21 to 24 mm	M8
from 24 to 30 mm	M10
from 30 to 38 mm	M12
from 38 to 50 mm	M16
from 50 to 85 mm	M20
from 85 to 130 mm	M24

The motors are always supplied with the shaft key inserted.

The second shaft is able to transmit the full nominal output in the case of a coupled drive. The output transmitted by the second shaft end in the case of belt, chain and pinion drives can be notified upon request. Slotted drive elements, such as belt pulleys or couplings, must be balanced with a half-key to at least balance quality grade G 6.3 according to DIN ISO 1940-1.

True running of the shaft ends

The true running of the shaft ends complies with the requirements of EN 50347. The relevant values can be reduced by 50% as an option (extra charge).

Noise ratings

Noise levels are measured at rated output, rated voltage and rated frequency in accordance with EN ISO 3741. EN 60034-9 stipulates that the noise level in dB(A) is to be specified as the spatial mean value of the sound pressure level L_{pA} measured at a distance of 1 metre from the machine contour.

The A-weighted sound power level L_{WA} over the measuring surface L_s ($d = 1$ m) is calculated with

$$L_{WA} = L_{pA} + L_s \quad (\text{dB})$$

The measuring surface level is dependent on the machine geometry and is for

Frame size		L_s (dB)
56 – 132		12
160 – 225		13
250 – 315		14
355		15

The noise values for the main series are presented in tabular form. For machines in 60 Hz versions, a value 4 dB(A) higher than the table value can be taken as a guideline. Binding specifications for 60 Hz upon request. Consultation is necessary with regard to special series.

Winding and insulation

VEM motors of the series K21./K20. are designed for thermal class 155 [F] as standard. High-quality enamelled wires and insulating sheet materials are used in conjunction with low-solvent resin impregnation. The standard insulation system accommodates rated voltages up to 725 V [mains infeed]. It guarantees high mechanical and electrical strength, and provides for a long service life.

Motors are available in three versions:

- For converter-fed operation without filter up to 420 V converter output voltage
- For converter-fed operation without filter up to 500 V converter output voltage, curve A to DIN VDE 0530-25:2009
- For converter-fed operation without filter up to 690 V converter output voltage, curve B to DIN VDE 0530-25:2009

Rated voltage and frequency

In their basic versions, motors are supplied for the following rated voltages and frequencies:

230/400 V Δ /Y, 50 Hz	220...240 V Δ / 380...420 V Y, 50 Hz
400/690 V Δ /Y, 50 Hz	380...420 V Δ / 660...725 V Y, 50 Hz
500 V, 50 Hz	475...525 V, 50 Hz

275/480 V Δ /Y, 60 Hz	265...290 V Δ / 460...500 V Y, 60 Hz
600 V, 60 Hz	570...630 V, 60 Hz

The motors can be operated without modification of the rated output on mains systems where the voltage at rated frequency deviates by up to + 5% from the nominal value (rated voltage range A). At rated voltage, the frequency in these mains systems may deviate by $\pm 2\%$ from the nominal value. The aforementioned standard voltages to DIN IEC 60038 are taken to define the design point. Special voltages and frequencies are possible by customer request.

Motors which are to be suitable for a mains voltage to DIN IEC 60038 with an overall tolerance of $\pm 10\%$ are selected according to the corresponding rated voltage as listed in the technical tables. The rated voltage range limited by U_U and U_O is similarly specified there.

If the motors are fed with voltages between 95% and 105% of the rated voltage range (corresponding to the relevant mains voltage to DIN IEC 60038 $\pm 10\%$), then it is permissible – in accordance with EN 60034-1 – for the temperature-rise limit of the stator winding to be exceeded by approximately 10 K already at the voltage and frequency limits of the rated range, without taking into account the tolerances.

For motors of sizes 56 to 112 (DIN)/56 to 100 (progressive series), the current for the upper voltage range U_O is set such that, given normal setting of the motor circuit-breaker to $1.05 \times I_n$, the breaker will also not be tripped in no-load operation and at $\pm 5\%$ tolerance.

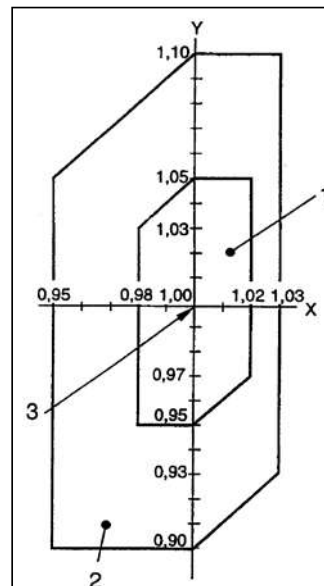

Fig. 15: Voltage and frequency limits for motors in accordance with EN 60034-1

- 1 Range A
- 2 Range B
- 3 Design point
- x Relative frequency f/f_N
- Y Relative voltage U/U_N

Rated output

The specified rated output applies for continuous operation to EN 60034-1 and refers to a coolant temperature of 40 °C, installation at an altitude ≤ 1,000 m above sea level, operating frequency 50 Hz and rated voltage. The series AE1R/AE2R possess thermal reserves which permit the following type-dependent continuous loads:

- Output up to 10% above rated output at coolant temperature 40 °C
 - Rated output up to coolant temperature 50 °C
 - Rated output at altitudes up to 2500 m
- The above alternative conditions are mutually exclusive. If more than one condition applies, it is necessary to reduce the output. In such cases, consultation with the manufacturer is recommended.

Motor torque

The rated torque (in Nm) delivered at the motor shaft amounts to

$$M = 9550 \cdot \frac{P}{n}$$

where P = Rated output in kW
n = Speed in rpm

In the motor selection data, the starting, pull-up and break-down torques are given as multiples of the rated torque. If the voltage deviates from its rated value, this results in an approximately quadratic change in the torque.

Ambient temperature

All VEM motors are suitable for ambient temperatures from -20 °C to +40 °C in their basic versions. Motors can be used at ambient temperatures down to -40 °C, provided they have been ordered specifically for such conditions. In case

of deviating ambient temperatures at installation sites below 1,000 m above sea level, the following factors are applied to determine the permissible output, depending on the thermal class:

Coolant temperature °C	10	15	20	25	30	35	40	45	50	55	60	70
Thermal class factor F	1.21	1.17	1.14	1.10	1.07	1.03	1.00	0.95	0.90	0.85	0.80	0.68

Table 5: Factors for adjustment of the permissible output in case of deviating coolant temperatures

If frequent moisture condensation is to be expected at the place of motor installation, we recommend the use of a space heater or other suitable precautions.

Installation altitude

Unless specified otherwise by the customer, it is assumed that the place of installation is not more than 1,000 m above sea level. If the machine is to be operated at an altitude above 1,000 m but below 4,000 m above sea level, the limit values for the temperature rise remain unchanged. The rated output, however, is subject to the following adjustment factors:

In case of installation at altitudes > 4000 m, the limit values for temperature rise must be agreed separately between the manufacturer and the customer.

Altitude above sea level in m	Coolant temperature in °C					
	< 30	30 – 40	45	50	55	60
1000	1.07	1.00	0.95	0.90	0.85	0.80
1500	1.04	0.97	0.93	0.89	0.84	0.79
2000	1.00	0.94	0.90	0.86	0.82	0.77
2500	0.96	0.90	0.86	0.83	0.78	0.74
3000	0.92	0.86	0.82	0.79	0.75	0.70
3500	0.88	0.82	0.79	0.75	0.71	0.67
4000	0.82	0.77	0.74	0.71	0.67	0.63

Table 6: Adjustment factors for altitude/coolant temperature

Overload capacity

In accordance with EN 60034-1, all motors can be subjected to the following overload conditions:

- 1.5 x rated current for a duration of 2 minutes
- 1.6 x rated torque for a duration of 15 seconds

Both conditions apply for rated voltage and rated frequency.

Rated efficiency and power factor

The efficiency η and the power factor $\cos \varphi$ are given in the lists of motor selection data.

Restarting with residual field and phase opposition

When an electric machine is switched off, a voltage system remains effective in its winding for a short time on account of the decaying magnetic field. Restarting could result in tran-

sient electrodynamic reactions in the machine. VEM motors can be restarted against a 100% residual field and phase opposition after mains failure.

Motor protection

Upon request, the following motor protection variants are possible:

- Motor protection with PTC thermistors as temperature sensors in the stator winding
- Bi-metal temperature sensor as normally closed or normally open contact in the stator winding

- KTY silicon sensors
- Resistance thermometer for winding or bearing temperature monitoring
- Bearing vibration diagnosis

Duty type

Special duty type for switched operation, short-time operation or electric braking are possible upon request. EN 60034-1 defines the following nominal duty type, which take into account thermal and mechanical conditions:

Duty type S1 – Continuous duty

Operation with a constant load which remains effective for a sufficient duration for the machine to reach thermal equilibrium. If no duty type is indicated on the name plate, the motor is designed for continuous duty S1. In the motor selection data lists, the rated data are specified for this duty type.

Duty type S2 – Short-time duty

Operation with a constant load which does not remain effective for a sufficient duration for the machine to reach thermal equilibrium, and a subsequent period of standstill with de-energised windings which is sufficient for the machine temperature to fall back to a level which deviates from the temperature of the coolant by less than 2 K. In case of duty type S2, the duration of operation must be specified.

Duty type S3 – Intermittent periodic duty

Operation which comprises a succession of identical type, each of which consists of a period of operation with constant load and a period of standstill with de-energised windings, where the starting current does not significantly influence the temperature rise. The specification of this duty type must be accompanied by indication of the cyclic duration factor. Periodic duty means that the state of thermal equilibrium is not reached during the period of the load.

Duty type S4 – Intermittent periodic duty with starting

Operation which comprises a succession of identical type, each of which consists of a distinct starting period, a period of operation with constant load and a period of standstill with de-energised windings. The specification of this duty type must be accompanied by indication of the cyclic duration factor, the mass moment of inertia of the motor and the mass moment of inertia of the load, with the latter both referring to the motor shaft. Periodic duty means that the state of thermal equilibrium is not reached during the period of the load.

Duty type S5 – Intermittent periodic duty with electric braking

Operation which comprises a succession of identical type, each of which consists of a starting period, a period of operation with constant load, a period of electric braking and a period of standstill with de-energised windings. The specification of this duty type must be accompanied by

indication of the cyclic duration factor, the mass moment of inertia of the motor and the mass moment of inertia of the load, with the latter both referring to the motor shaft. Periodic duty means that the state of thermal equilibrium is not reached during the period of the load.

Duty type S6 – Continuous operation with intermittent load

Operation which comprises a succession of identical type, each of which consists of a period of operation with constant load and a period of no-load operation. No standstill with de-energised windings occurs. The specification of this duty type must be accompanied by indication of the cyclic duration factor. Periodic duty means that the state of thermal equilibrium is not reached during the period of the load.

Duty type S7 – Continuous periodic duty with electric braking

Operation which comprises a succession of identical type, each of which consists of a starting period, a period of operation with constant load and a period of electric braking. No standstill with de-energised windings occurs. The specification of this duty type must be accompanied by indication of the mass moment of inertia of the motor and the mass moment of inertia of the load (both referring to the motor shaft).

Duty type S8 – Continuous operation with periodic changes in load and speed

Operation which comprises a succession of identical type, each of which consists of a period of operation with constant load and at a certain speed, followed by one or more periods of operation with other constant loads in accordance with different speeds. (This may be the case with pole-changing asynchronous motors, for example.) No standstill with de-energised windings occurs. The specification of this duty type must be accompanied by indication of the mass moments of inertia of the motor and load (both referring to the motor shaft), as well as the load, speed and cyclic duration factor for each relevant speed.

Duty type S9 – Continuous operation with non-periodic load and speed variation

Operation during which the load and speed generally vary non-periodically within a permissible operating range. This duty type frequently leads to overloads which far exceed the reference load. A suitable constant load corresponding to duty type S1 must be selected as the reference value for overload.

Duty type S10 – Operation with discrete constant loads

Operation characterised by no more than four discrete loads (or equivalent loads), each of which remains effective for a sufficient duration for the machine to reach thermal equilibrium. The smallest load within this duty type may be zero (no-load operation or standstill with de-energised windings). For this duty type, a suitable constant load corresponding to duty type S1 must be selected as the reference value for the individual loads.

Forced ventilation, type of cooling IC 416

Motors with forced ventilation can be used to improve the cooling effect during periods of standstill in case of switched operation (duty type S2 to S5). The use of such motors is similarly recommended to increase the available motor output in the low speed range in converter-fed operation (setting range 1:5, 1:10) or to reduce the noise level when operating motors on a converter at frequencies > 60 Hz. Depending on the required type of protection, either radial fans (protection from IP 55) or axial fans pro-

tection up to IP 55) may be used, though reductions in the type of protection may apply in individual cases. A separate rating plate with corresponding type data is attached to the forced ventilation unit. When connecting axial fan units, it is imperative to observe the direction of rotation! Forced ventilation units with electrical inputs greater than 125 W are compliant with Commission Regulation (EU) No. 327/2011 (Ecodesign requirements for fans).

Non-ventilated motors, type of cooling IC 410

These motors are designed without their own fan and without fan shroud. The motors are fully enclosed at the N-end up to shaft height 250; from shaft height 280, the sealing at the N-end is realised with grey-cast bearing covers as in the basic version. The rated output is reduced in accord-

ance with the reduced cooling, and the motor windings are adapted to this reduced output. If non-ventilated motors are installed in a cooling air flow, higher outputs may be possible upon request, depending on the cooling effect achieved.

Brake motors

VEM brake motors comprise a three-phase squirrel-cage motor and a built-on brake from the relevant manufacturer. The brakes are designed as double-face brakes and function according to the fail-safe principle. The brake system is supplied as a compact unit ready for connection and assembly, for which the most varied brake torques and versions can be realised, depending on the version ordered. The holding torque of a brake motor is always effective when the motor is in a no-voltage state. Compression springs exert a force on the axially movable armature disc and establish the brake torque by way of friction linings. The brake torque is transferred to the shaft via the keyed mounting of the lining carrier or a toothed driver hub. When a voltage is applied to the brake coil, the armature disc is pulled back and the friction linings are released to enable the motor to turn.

Note

A number of different circuit variants are possible to influence the switching time of the brake. In the basic version, the brake coil is controlled either directly with the corresponding (DC) coil voltage via a two-pole terminal in the motor terminal box, or else with an appropriate AC voltage by way of the separately supplied rectifier module. For the special version "ready for connection", the brake coil may be wired parallel to one phase of the motor winding by way of a rectifier module in the motor terminal box, depending on the frame size.

Special output assignments apply for brake motors for use in hoists and lifting gear (duty type S3), depending on the individual operating time. The relevant values can be taken from the special tables.

Paint finish

Paint finishes must withstand the most diverse stresses and influences in order to ensure long-term reliable protection. With the switch to low-solvent paint systems, VEM has adapted its production to the tightened demands of the 31st Ordinance on Implementation of the Federal Immission Control Act (Ordinance regarding the reduction of VOC emissions resulting from the use of organic solvents in specific installations – German Solvent Ordinance) [31. BImSchV] and is thus making an active contribution to the improvement of environmental protection.

Normal paint finish

Suitable for climate group “moderate” in accordance with IEC 60721-2-1: Indoor and outdoor installation, moderate climate (short-time exposure to relative humidity up to 100% at temperatures up to +30 °C; continuous exposure to relative humidity up to 85% at up to +25 °C)

Special paint finish

Suitable for climate group “worldwide” in accordance with IEC 60721-2-1: Outdoor installation in atmospheres with a general tendency to increased stress, tropical climate (short-time exposure to relative humidity up to 100% at temperatures up to +35 °C; continuous exposure to relative humidity up to 98% at up to +30 °C)

01 Moderate WK F/H RAL 7031	01 S Moderate WK F	02 World- wide WK F/H RAL 7031	02 S Worldwide WK F Special colour*	03 Customer request	04 Special finish	06 Moderate/ Worldwide WK H Special colour*	07 Special finish	08 Primed	09 L Light-duty offshore finish	09 S Heavy-du- ty offshore finish
Heat, indoors, outdoors under cover	Heat, indoors, outdoors under cover	Heat, outdoors, indoors with high humidity	Heat, outdoors, indoors with high humidity		Marine climate, ports	Heat, humidity, outdoors	Chemicals, heat, humidity, high corrosion protection	Prepared for further painting	UV- resistant, outdoors, high corrosion protection	Offshore marine cli- mate, further enhanced corrosion protection
≥ 70 µm	≥ 70 µm	≥ 110 µm	≥ 110 µm		≥ 150 µm	≥ 110 µm	≥ 150 µm	≥ 70 µm	≥ 210 µm	≥ 240 µm
up to 120 °C short-time 180 °C	up to 100 °C short-time 120 °C	up to 120 °C short-time 180 °C	up to 100 °C short-time 120 °C		up to 80 – 90 °C short-time 130 °C	up to 120 °C short-time 180 °C	up to 120 °C short-time 180 °C		up to 100 °C short-time 140 °C	up to 100 °C short-time 140 °C
KK C2	KK C2	KK C2 – C3	KK C2 – C3			KK C2 – C3	KK C3		KK C3	KK C4/5
2K-EP TC (water-based) 40 µm	2K-PUR TC 40 µm	2K-EP TC (water-based) 40 µm 2K-EP primer (water-based) 40 µm	2K-PUR TC 40 µm 2K-EP primer (water-based) 40 µm	Customer request	2K-EP, ceramic-filled 120 µm	2K-EP TC 40 µm 2K-EP primer (water-based) 40 µm	2K-EP TC 40 µm 2K-EP primer (water-based) 80 µm	2K-EP primer (water-based) 40 µm	2K-PUR TC 80 µm 2K-EP primer (water- based) 100 µm	2K-PUR TC 80 µm 2K-EP primer 110 µm 2K-EP- zinc dust 50 µm
Grey cast iron/fan shrouds: Water-thinned primers, approx. 30 µm Sheet-metal terminal boxes: Powder-coated										
Grit blasting with SA 2.5/SIS 055900 for grey cast iron parts Cleaning/pickling for sheet metal parts										

Special colour*: Paint finish 01 not available in RAL 1000 to 2011, RAL 7047, 9001, 9002, 9005, 9010, 9011, 9016, 9017 and light ivory textured paint 1015, KK

Fig. 16: Paint finishes after switch to water-soluble paint systems

If no colour is specified, all motors are supplied in **RAL 7031 “Blue grey”**. If a different colour is required, the corresponding RAL number and colour designation must be specified at the time of ordering. VEM paint systems provide lasting, high-

performance corrosion protection. Their functional capabilities have been proven in exacting and comprehensive test series. Customer-specific paint systems are always subject to prior consultation.

Modular construction of different series and modifications

The design concepts of the different series provide for the optional incorporation of components such as pulse generators, tacho generators, brakes, speed monitors or forced ventilation units to solve the customer's individual control tasks.

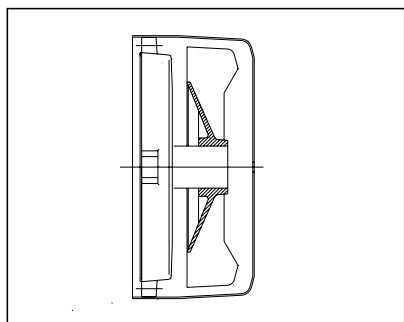

Standard version
Type of cooling IC 411, self-ventilated

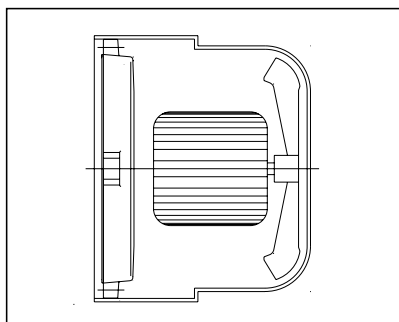

Special version
Type of cooling IC 416, forced ventilation

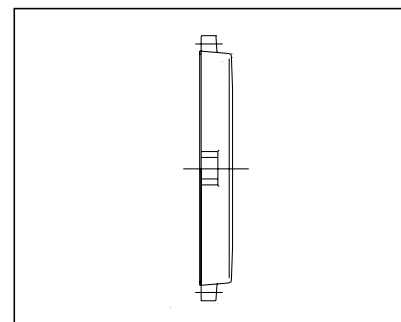

Special version
Type of cooling IC 410, non-ventilated

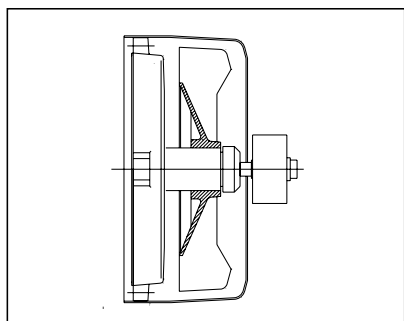

Special version
Type of cooling IC 411, self-ventilated with built-on incremental encoder

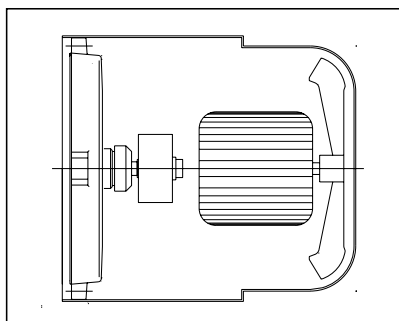

Special version
Type of cooling IC 416, forced ventilation with built-on incremental encoder

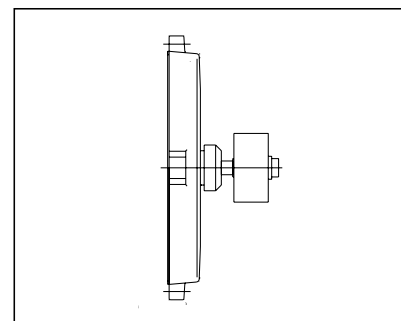

Special version
Type of cooling IC 410, non-ventilated with built-on incremental encoder

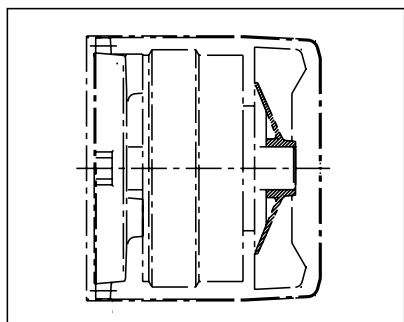

Special version
Type of cooling IC 411, self-ventilated with built-on brake

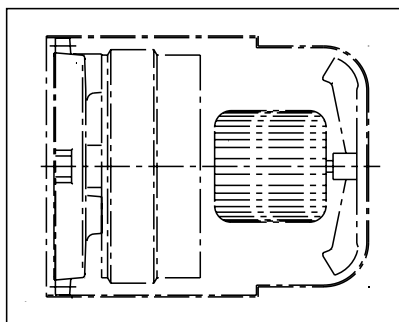

Special version
Type of cooling IC 416, forced ventilation with built-on brake

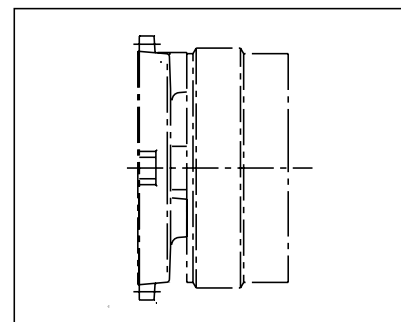

Special version
Type of cooling IC 410, non-ventilated with built-on brake

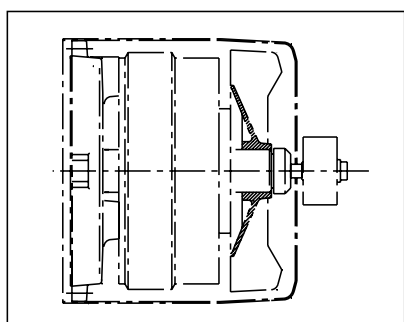

Special version
Type of cooling IC 411, self-ventilated with built-on brake and incremental encoder

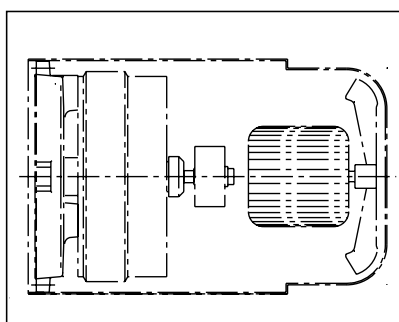

Special version
Type of cooling IC 416, forced ventilation with built-on brake and incremental encoder

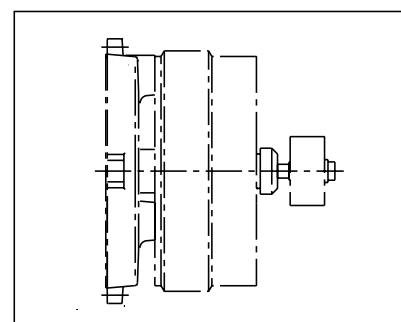

Special version
Type of cooling IC 410, non-ventilated with built-on brake and incremental encoder

1

Maintenance

Attention is drawn expressly to the safety notes and instructions, and here in particular to the procedures for safe isolation, safeguarding against accidental restarting, and checking the proper disconnection of all components connected to a voltage source. When a motor is disconnected from the mains supply for maintenance purposes, particular care must be taken to ensure that any auxiliary circuits, e.g. space heaters, forced ventilation fans or brakes, are similarly disconnected from their power supply. If it is necessary to dismantle the motor to perform maintenance work, the sealing compound left on the centring edges must be removed. New sealing compound

of a suitable type is to be used for sealing when the motor is reassembled. Any copper sealing rings must always be refitted.

Careful and regular maintenance and inspection is imperative, so as to be able to detect and rectify any arising problems in good time before further damage is caused. As the operating conditions are not exactly defined, it is only possible to specify general maintenance intervals, under the assumption of trouble-free operation. These intervals must always be adapted in accordance with the local circumstances (contamination, loads, etc.).

What is to be done?	Regular interval	Max. interval
Initial inspection	After approx. 500 operating hours	At the latest after six months
Check of air passages and motor surface	Depending on degree of local contamination	
Relubrication (option)	See name plate or lubrication plate	
Main inspection	Approx. 10,000 operating hours	Once a year
Drain condensation	Depending on climatic conditions	

Inspections

Initial inspection

In accordance with the specifications, an initial inspection of the motor should be performed after approx. 500 operating hours, but at the latest after six months.

The following checks are to be performed with the motor at standstill:

- a) Check the foundation. There must be no cracks or other damage such as depressions or the like.

The following checks are to be performed with the motor running:

- a) Check the electrical parameters.
- b) Check the bearing temperatures. It is to be determined whether the permissible bearing temperatures are exceeded during operation of the motor.
- c) Check for unusual noises during operation. An acoustic check is performed to determine whether the quiet running of the motor has deteriorated.

If the checks reveal any deviations from the values specified in the operating and maintenance manual, or any other defects or errors, these deviations and defects must be rectified immediately.

Main inspection

In accordance with the specifications, a main inspection should be performed once a year or after approx. 10,000 operating hours.

The following checks are to be performed with the motor at standstill:

- a) Check the foundation. There must be no cracks or other damage such as depressions or the like.
- b) Check the alignment of the motor. The alignment must lie within the specified tolerances.
- c) Check the mounting screws and bolts. All screws and bolts which are used to make mechanical and electrical

joints and connections must be properly tight (see also the table of tightening torques for screws and bolts under Section 11 "Commissioning" of the operating and maintenance manual).

- d) Check the cables and the insulation materials. It is to be checked whether the cables and the insulation materials used are in a good and proper condition. They must not display discolouration, and in particular not burn marks, and must not be broken, cracked or otherwise damaged.
- e) Check the insulation resistance. When checking the insulation resistance of the winding, observe the specifications given in the operating and maintenance manual (Section 9).
- f) Depending on the grease quality and the bearings of the motor, it may also be necessary to replace the grease of the anti-friction bearings after 10,000 operating hours (see also Section 13 "Bearings and lubrication" of the operating and maintenance manual). Otherwise, the specified relubrication intervals for the anti-friction bearings must be observed separately, as they deviate from the inspection intervals.

The following checks are to be performed with the motor running:

- a) Check the electrical parameters.
- b) Check the bearing temperatures. It is to be determined whether the permissible bearing temperatures are exceeded during operation of the motor.
- c) Check for unusual noises during operation. An acoustic check is performed to determine whether the quiet running of the motor has deteriorated.

If the checks reveal any deviations from the values specified in the operating and maintenance manual, or any other defects or errors, these deviations and defects must be rectified immediately.

Long-term storage (over 12 months)

If long-term storage is necessary, motors must be protected from vibration and kept in closed, dry rooms at temperatures between -20 and +40 °C and in an atmosphere free from aggressive gases, vapours, dusts and salts. Motors should preferably be transported and stored in their original packaging. Storage and transport resting on the fan shrouds is not permissible. Unprotected metal surfaces, for example shaft ends and flanges, are to be provided with long-term corrosion protection, in addition to the temporary corrosion protection applied before motors leave the factory.

If the motors are subject to condensation under the given ambient conditions, precautions are to be taken to protect the motors against moisture. In such cases, the motors

must be specially packed in air-tight welded foil or under plastic foil with appropriate desiccants. Desiccant sachets are also to be placed in the motor terminal boxes.

For transport, the ring bolts/load beams of the motors are to be used together with appropriate lifting tackle. The ring bolts/load beams are only intended for lifting of the bare motor without additional built-on parts such as base plate, gearing, etc.

Motors with reinforced bearings are supplied with a transport brace. The transport brace on the shaft end should only be removed after assembly of the motor and prior to the first starting.

Disposal

The applicable national regulations are to be observed with regard to disposal of the machines.

It is furthermore to be ensured that oils and greases are collected for disposal in accordance with the corresponding regulations on waste oils. They must not be contaminated with solvents, cold cleaners and paint residues.

The individual materials should be segregated for recycling. The most important components are grey cast iron (housing), steel (shaft, stator and rotor lamination, small parts), aluminium (rotor), copper (windings) and plastics (insulation materials, such as polyamide, polypropylene, etc.). Electronic components such as circuit boards (converter, sensors, etc.) are recycled separately.

Warranty, repairs, spare parts

Our authorised service workshops are responsible for all warranty repairs, unless expressly agreed otherwise. They can also be contacted in connection with any other repairs which may become necessary. Information on our customer service network can be requested from our central

offices. Maintenance in accordance with the instructions given in the section "Maintenance" is not considered a breach of the warranty stipulations. It thus cannot be deemed to release the manufacturer from any agreed warranty obligations.

Bearings

Series ARC

Type	D-end								N-end	
	Anti-friction bearing	Gamma ring	Radial shaft seal 1	Sealing grease amount in g	Radial shaft seal 2	Bushing	Bushing	Cup spring	Anti-friction bearing	Fixed bearing
ARC 112 M, MX	6207 C3	9RB 35 FKM	40 x 62 x 7	-	-	IR 35 x 40 x 17 EGS	72	-	6207 C3	N-end
ARC 132 S, M	6308 C3	9RB 40 FKM	45 x 65 x 8	50	-	IR 40 x 45 x 17 EGS	90	-	6308 C3	
ARC 160 S, M	6310 C3	9RB 50 FKM	55 x 75 x 7	70	55 x 85 x 8	IR 50 x 55 x 20 EGS	110	-	6309 C3	
ARC 180 S, M	6312 C3	9RB 60 FKM	70 x 90 x 7	80	70 x 100 x 10	IR 60 x 70 x 25 EGS	-	130	6310 C3	
ARC 200 S, M, L, LX	6313 C3	9RB 65 FKM	72 x 95 x 10	90	72 x 100 x 10	IR 65 x 72 x 25 EGS	-	140	6312 C3	
ARC 225 M	6314 C3	9RB 70 FKM	80 x 100 x 7	100	80 x 110 x 10	IR 70 x 80 x 30 EGS	-	150	6313 C3	
ARC 250 S, M	6316 C3	9RB 80 FKM	90 x 110 x 7,5	110	90 x 120 x 12	IR 80 x 90 x 30 EGS	-	170	6314 C3	
ARC 280 S, M	6317 C3	9RB 85 FKM	95 x 120 x 12	120	95 x 125 x 12	IR 85 x 90 x 36 EGS	-	180	6316 C3	
ARC 315 M, MX ARC 315 L, LX	6320 C3	9RB 95 FKM	105 x 130 x 12	130	105 x 140 x 12	IR 95 x 105 x 36 x EGS	-	215	6317 C3	
ARC 355 M, MX, LY, L	6324 C3	9RB 110 FKM	125 x 150 x 15	150	125 x160x12	IR 110 x 125 x 40 EGS	-	260	6317 C3	
ARC 400 L, LX	6324 C3	9RB 110 FKM	125 x 150 x 15	150	125 x160x12	IR 110 x 125 x 40 EGS	-	260	6321 C3	

Lubricating grease Berutox FH28KN (KHC1R-30 DIN 51825)

¹ Special version with insulated bearing on N-end

Series ARB

Type	Anti-friction bearings D-end and N-end	Fixed bearing
ARB 22, ARB 33	6306 S1 C5	N-end
ARB 54, ARB 65	6310 S1 C5	

Lubricating grease Berutox FH28KN (KHC1R-30 DIN 51825)

Limit speeds

If motors are operated at above the rated speed, the limit values of the anti-friction bearings, the strength of the rotating parts, critical rotor speeds and the circumferential speed of the fans must be observed.

The limit speeds specified in the table below may already require precautionary measures such as special fans, special bearings or special balancing.

Type	Synchronous speed at 50 Hz		
	1500 rpm	1000 rpm	750 rpm
ARC 112	3600	2400	1800
ARC 132	3600	2400	1800
ARC 160	3000	2000	1500
ARC 180	3000	2000	1500
ARC 200	3000	2000	1500
ARC 225	3000	2000	1500
ARC 250	3000	2000	1500
ARC 280	3000	2000	1500
ARC 315	3000	2000	1500
ARC 355	3000	2000	1500
ARC 400	3000	2000	1500
ARB 22, 33	3600	2400	1800
ARB 54, 65	3000	2000	1500

Tolerances Electrical parameters

According to DIN EN 60034-1, the following tolerances are permissible:

Efficiency (when determined indirectly)	-0.15 (1- η) at $P_N \leq 150$ kW -0.1 (1- η) at $P_N > 150$ kW
Power factor	$\frac{1-\cos\varphi}{6}$ min. 0.02 max. 0.07
Slip (with nominal load and at operating temperature)	± 20 % at $P_N \geq 1$ kW ± 30 % at $P_N < 1$ kW
Starting current (with intended starting circuit)	+20 % no lower limit
Starting torque	- 15 % and + 25 %
Pull-up torque	- 15 %
Breakdown torque	- 10 % (M_K/M_N still at least 1.6 after application of this tolerance)
Moment of inertia	± 10 %
Noise level (sound pressure level at measuring surface)	+3 dB (A)

These tolerances are applicable to the guaranteed values for three-phase asynchronous motors, taking into account necessary manufacturing tolerances and possible deviations in the raw materials used. The standard includes the following notes:

1. It is not intended that guarantees necessarily have to be given for all or any of the items involved. Quotations including guaranteed values subject to tolerances should

say so, and the tolerances should be in accordance with the table.

2. Attention is drawn to the different interpretation of the term "guarantee". In some countries, a distinction is made between guaranteed values and typical or declared values.
3. Where a tolerance is stated in only one direction, the value is not limited in the other direction.

Mechanical parameters – Usual tolerances

Dimension symbol to DIN EN 50347	Meaning of dimension	Fit or tolerance
B [a]	Spacing of fixing holes for housing feet in axial direction	± 1 mm
P [a]	Diameter or width across corners of flange	- 1 mm
A [b]	Spacing of fixing holes for housing feet transverse to axial direction	± 1 mm
N [b]	Diameter of centring edge of mounting flange	up to diameter 230 mm j6 from diameter 250 mm h6
D, DA [d, d ₁]	Diameter of cylindrical shaft end	up to diameter 48 mm k6 from diameter 55 mm m6
M [e]	Pitch circle diameter of mounting flange	± 0.8 mm
AB [f], AC [g]	Greatest width of motor (without terminal box)	+ 2 %
H [h]	Shaft height (bottom edge of foot to centre of shaft end)	up to 25 - 0.5 mm over 250 - 1 mm
L, LC [k, k ₁]	Total motor length	+ 1 %
HD [p]	Total motor height (bottom edge of foot, housing or flange to highest point of motor)	+ 2 %
K, K' [s, s ₁]	Diameter of mounting holes of foot or flange	+ 3 %
GA, GC [t, t ₁]	Bottom edge shaft end to top edge key	+ 0.2 mm
F, FA [u, u ₁]	Width of key	h9
C, CA [w ₁ , w ₂]	Distance from centre of first foot mounting hole to shaft shoulder or flange face	± 3.0 mm
	Distance from shaft shoulder to flange face with fixed bearing at D-end	± 0.5 mm
	Distance from shaft shoulder to flange face	± 3.0 mm
m	Motor mass	- 5 bis + 10 %

Usual fits for shaft ends

Shaft ends	up to $\varnothing 48$	k6
	from $\varnothing 55$	m6
Mating part		H7

Types of construction

The most common types of construction are shown in the table below. Further types of construction can be supplied upon request. The type of construction is indicated on the name plate in accordance with Code I, EN 60034-7. Standard motors which are ordered in a basic type in sizes 56 to 200 can also be operated with the following derived types of construction.

- IM B3 in IM B5, IM B7, IM B8 and IM V6
- IM B35 in IM 2051, IM 2061, IM 2071 and IM V36
- IM B34 in IM 2151, IM 2161, IM 2171 and IM 2131
- IM B5 in IM V3
- IM B14 in IM V19

Motors of types IM V5, IM V1 or IM V18 can be designed with an optional protective canopy to prevent small parts falling into the motor. With types of construction with the shaft end pointing upwards, it is the responsibility of the user to provide a suitable cover to prevent small parts falling into the fan shroud (see also standard IEC/EN 60079-0). The cooling air flow must not be hindered by the cover. From size 225, it is necessary to consult the manufacturer regarding types of construction IM V5, IM V6, IM B6, IM B7 and IM B8. The types of construction IM B5 and IM V3 are not available for frame sizes from 315 L. To facilitate connection to the mains power supply, the terminal box can be rotated by 90° with all types of construction.

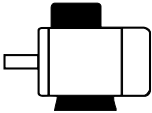
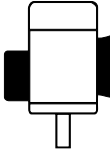
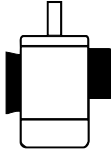
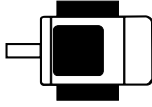
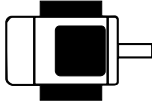
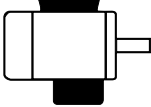
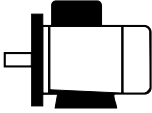
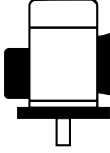
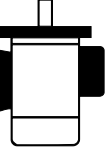
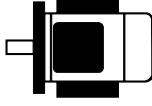
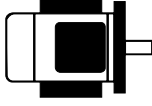
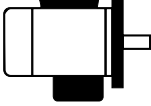
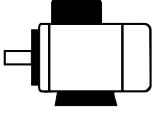
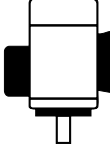
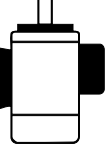
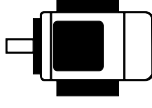
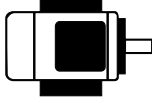
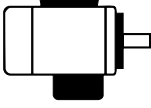
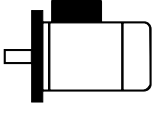
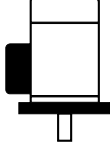
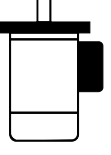
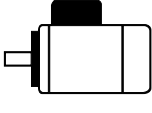
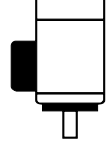
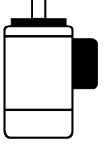
Basic type of construction	Derived types of construction					
IM B3 IM 1001 	IM V5 IM 1011 	IM V6 IM 1031 	IM B6 IM 1051 	IM B7 IM 1061 	IM B8 IM 1071 	
IM B35 IM 2001 	IM V15 IM 2011 	IM V36 IM 2031 	IM 2051 	IM 2061 	IM 2071 	
IM B34 IM 2101 	IM 2111 	IM 2131 	IM 2151 	IM 2161 	IM 2171 	
IM B5 IM 3001 	IM V1 IM 3011 	IM V3 IM 3031 				
IM B14 IM 3601 	IM V18 IM 3611 	IM V19 IM 3631 				

Terminal boxes

Motor type	Terminal box	Material	Length	Width	Height	Standard cable gland	Max. cable diameter	Terminal mounting	Thread of terminal stud	Thread of protective conductor	Figure
			AG	LL	-	o	Ø max				
ARC 112	25 A	GG15	143	134	70	M32 x 1.5	Ø 21 mm	K1M5	M5	KB*	01
ARC 132	25 A	GG15	143	134	70	M32 x 1.5	Ø 21 mm	K1M5	M5	KB*	01
ARC 160	25 A	GG15	143	134	70	M32 x 1.5	Ø 21 mm	K1M5	M5	KB*	01
ARC 180	63 A	GG15	175	162	81	M40 x 1.5	Ø 28 mm	K1M6	M6	KB*	01
ARC 200	100 A	GG15	213	207	101	M50 x 1.5	Ø 35 mm	K1M8	M8	M8	01
ARC 225	100 A	GG15	213	207	101	M50 x 1.5	Ø 35 mm	K1M8	M8	M8	01
ARC 250	200 A	GG15	282	242	131	M63 x 1.5	Ø 45 mm	K1M10	M10	M10	01
ARC 280	200 A	GG15	282	242	131	M63 x 1.5	Ø 45 mm	K1M10	M10	M10	01
ARC 315	200 A	GG15	282	242	131	M63 x 1.5	Ø 45 mm	K1M10	M10	M10	01
ARC 355	400 A	GG15	311	297	152	M63 x 1.5	Ø 45 mm	KM12	M12	M10	02
ARC 400	400 B	GG15	415	340	176	M63 x 1.5	Ø 45 mm	KM16	M16	tab	02
ARB		GG15	130	130		M32 x 1.5	Ø 21 mm	KBS6	M6	M6	none

KB* ... Terminal clamp

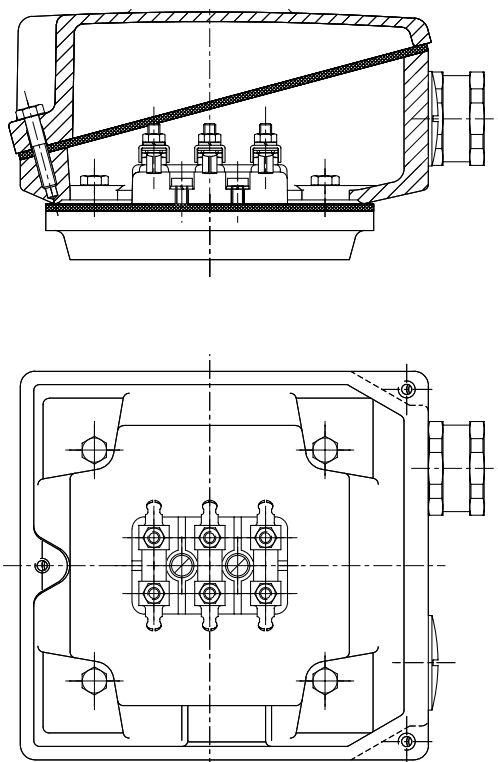

Figure 01

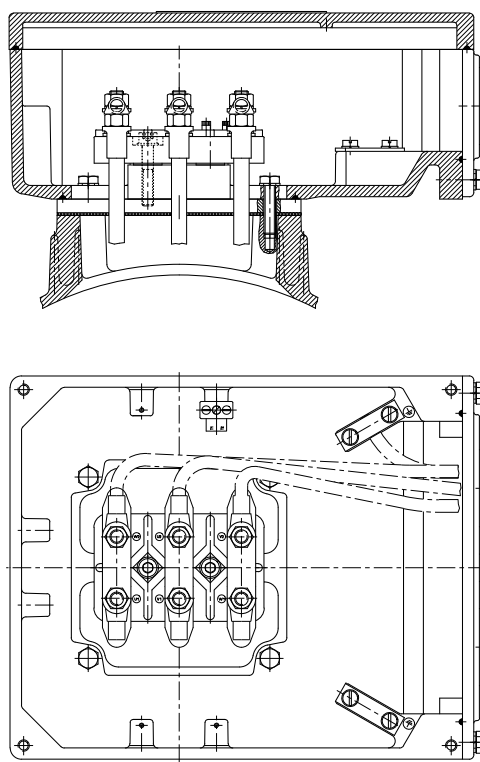

Figure 02



Heavy-duty roller table motors

Series ARB for mains operation
Series ARC for converter-fed operation

Heavy-duty roller table motors

Series ARB for mains operation
Series ARC for converter-fed operation

The most important technical data are summarised in the following table. Further information can be taken from the catalogue section "Technical explanations".

Product group	Roller table motors, squirrel-cage rotor, IEC/DIN
Series	ARB... version for mains operation ARC... version for converter-fed operation, IEC 60034-17, converter output voltage up to 420 V Curve A, IEC TS 60034-25, converter output voltage > 420 up to 500 V Curve B, IEC TS 60034-25, converter output voltage > 500 up to 690 V
Rated output	ARB... 0.4 kW to 5.5 kW ARC... 0.4 kW to 290 kW
Sizes	ARB... 22 (132), 33 (125), 54 (170) and 65 (200) ARC... 112 to 400
Housing material	Grey cast iron
Rated torque	ARB... 8 to 77 Nm ARC... 8 to 2560 Nm
Method of connection	Single-speed motors are designed in star-delta configuration as standard.
Stator winding insulation	Thermal class 155, optional 155 [F(B)], 180 to EN 60034-1 (IEC 60034-1)
Type of protection	IP 55 acc. to EN 60034-5 (IEC 60034-5) optionally IP 56 and higher
Type of cooling	IC 410 [non-ventilated] acc. to EN 60034-6 (IEC 60034-6)
Coolant temperature/ installation altitude	Standard -20 °C to +40 °C, Altitude 1,000 m above sea level
Rated voltage	Rated voltage range A to EN 60034-1 (IEC 60034-1) Standard voltages to EN 60038 50 Hz, 230 V, 400 V, 500 V, and 690 V 60 Hz, 275 V, 480 V and 600 V
Types of construction	IM B3, IM B35, IM B5 and derived types complying with DIN EN 60034-7
Paint finish	Normal finish "Moderate", colour RAL 7031, blue-grey Special finish "Worldwide", colour RAL 7031, blue-grey
Vibration severity grade	Grade "A" as standard for machines with no special vibration requirements
Shaft ends	acc. to DIN 748 (IEC 60072), balanced with half-key
Sound pressure level	acc. to DIN EN ISO 1680, tolerance +3 dB, see technical explanations for values
Limit speeds	See section "Limit speeds" in the chapter "Technical explanations"
Bearing design	See section "Bearings" in the chapter "Technical explanations"
Motor mass	See technical selection lists
Terminal box	See section "Terminal boxes" in the chapter "Technical explanations"
Documentation	An operating and maintenance manual, a terminal plan and a safety data sheet are supplied with each motor.
Tolerances	See section "Tolerances" in the chapter "Technical explanations"
Options	See "Overview of modifications" of the basic catalogue 01-2012 in the chapter "Technical explanations"

Three-phase roller table motors with squirrel-cage rotor for direct-on-line starting, series ARB

Non-ventilated with surface cooling, type of cooling IC 410, duty type S1, continuous duty, thermal class H, types of protection IP 44/IP 54, 50 Hz

Type	P	M _n	n	I _a	B		M _a	t _k	J	m
	kW	Nm	rpm	at 400 V A	IP 44 kgm ² /h	IP 54 kgm ² /h	Nm	min	kgm ²	kg
Synchronous speed 1500 rpm – 4-pole version										
ARB 22/4	1.1	8	1330	12	200	150	22.5	7.0	0.0140	60
ARB 33/4	2.2	15	1430	37	260	200	56.0	4.0	0.0430	90
Synchronous speed 1000 rpm – 6-pole version										
ARB 22/6	0.8	9	850	7	330	250	18.5	13.0	0.0140	60
ARB 33/6	1.5	15	940	21	570	440	53.0	10.0	0.0430	90
ARB 54/6	5.5	56	930	76	1400	1000	240.0	5.5	0.2330	200
Synchronous speed 750 rpm – 8-pole version										
ARB 22/8	0.6	9	650	7	480	370	22.5	20.0	0.0140	60
ARB 33/8	1.1	15	690	13	740	580	42.0	14.0	0.0430	90
ARB 54/8	4.0	56	680	49	1700	1300	190.0	5.5		
ARB 65/8	5.5	75	700	67	2450	1900	210	10.0	0.5750	290
Synchronous speed 600 rpm – 10-pole version										
ARB 33/10	0.8	14	530	8	1100	860	28.0	40.0	0.0430	90
ARB 54/10	3.0	52	555	36	2600	2000	170.0	18.0	0.2330	200
ARB 65/10	4.0	68	560	58	3600	2800	250	7.5	0.5750	290
Synchronous speed 500 rpm – 12-pole version										
ARB 33/12	0.4	8	460	7	1600	1200	29.0	55.0	0.0430	90
ARB 54/12	2.2	47	450	24	4000	3100	140.0	27.0	0.2330	200
ARB 65/12	3.0	63	455	32	5100	4000	200	20.0	0.5750	290
Synchronous speed 375 rpm – 16-pole version										
ARB 54/16	1.1	31	340	18	5100	4000	115.0	30.0	0.2330	200
ARB 65/16	2.2	60	350	33	8500	6600	200	28.5	0.5750	290
Synchronous speed 250 rpm – 24-pole version										
ARB 54/24	0.8	40	190	12	7000	5400	100.0	80.0	0.2330	200
ARB 65/24	1.5	68	210	25	13500	10600	175	50.0	0.5750	290
Synchronous speed 500/1000 rpm – 12/6-pole version										
ARB 54/12	2.5	54	440	26	3000	2300	135	10.0	0.2330	200
-6	4.0	42	920	43	750	600	100	2.2		
ARB 65/12	3.7	77	460	43	5200	4000	210	12.0	0.5750	290
-6	5.0	50	950	41	1500	1100	170	3.5		

t_k... max. permissible blocking period

B...Acceleration factor

B = J_G × z × k [kgm²/h]

J_G... Total moment of inertia in kgm² for motor + roller + load, referred to the motor shaft

z... Switching frequency in starts per hour

k... Factor to account for switched operation, k = 1 for simple starting, k = 4 for reversing

Three-phase roller table motors with squirrel-cage rotor for converter-fed operation, series ARC

Non-ventilated with surface cooling, IC 410

Planning data for switched operation calculations/motor pre-selection

Duty type S9, thermal class F, type of protection IP 55, rated frequency 50 Hz

Insulation system for \dot{U} max. 1.35 kV; du/dt max. 1.5 kV/ μ s

ARC	Equivalent S1 output						Transient peak load (max. 10 s)					No-load			
	P_{eff} (S1) kW	M_{eff} Nm	I_n 400 V A	n_n rpm	η_n referred to P_{eff} %	$\cos\varphi_n$ -	M_{max} Nm	M_{max}/M_{eff}	I_{max} A	η_{max} referred to M_{max} %	$\cos\varphi_{max}$ -	I_0 A	$\cos\varphi_0$ -	J kgm ²	m kg
Synchronous speed 1500 rpm – 4-pole version															
ARC 112 M4	2.3	15	4.7	1465	85.0	0.83	47	3.1	17	79.0	0.85	2.5	0.11	0.015	56
ARC 112 MX4	2.5	16	5.0	1465	85.0	0.85	49	3.0	18	77.0	0.87	2.5	0.10	0.017	63
ARC 112 MZ4	3.0	20	5.9	1460	86.0	0.85	60	3.0	19	75.0	0.88	2.8	0.11	0.020	67
ARC 132 S4	3.0	19	6.6	1480	85.0	0.77	61	3.2	20	84.0	0.81	3.8	0.13	0.028	82
ARC 132 M4	4.4	28	9.2	1475	87.5	0.79	93	3.3	30	82.0	0.89	5.3	0.10	0.035	95
ARC 132 MX4	6.2	40	12.5	1475	88.5	0.80	120	3.0	38	82.0	0.84	6.8	0.08	0.044	105
ARC 160 S4	5.5	35	11.5	1480	88.0	0.80	105	3.0	32	85.0	0.84	6.0	0.13	0.078	130
ARC 160 M4	7.7	50	16.0	1480	89.0	0.79	150	3.0	52	85.0	0.84	8.5	0.11	0.090	144
ARC 160 MX4	8.0	52	17.0	1480	89.5	0.77	160	3.1	52	85.0	0.84	9.5	0.11	0.104	160
ARC 160 L4	10.2	66	20.0	1480	88.5	0.83	200	3.0	68	86.0	0.85	10.0	0.13	0.116	170
ARC 180 S4	8.8	57	18.5	1480	86.0	0.80	175	3.1	55	84.5	0.83	12.0	0.07	0.138	170
ARC 180 M4	11.0	71	22.0	1485	90.5	0.80	215	3.0	72	90.0	0.85	15.0	0.07	0.168	215
ARC 180 L4	14.0	90	27.5	1480	90.5	0.81	270	3.0	80	88.0	0.85	17.0	0.09	0.203	250
ARC 200 M4	15.0	100	29.5	1475	91.0	0.80	307	3.1	94	91.1	0.85	15.0	0.08	0.275	270
ARC 200 L4	18.5	119	35.0	1485	92.5	0.82	367	3.1	115	91.5	0.82	16.0	0.09	0.313	335
ARC 200 LX4	20.0	128	39.5	1485	91.5	0.80	380	3.0	121	83.0	0.84	20.5	0.09	0.356	350
ARC 225 M4	22.0	141	43.0	1485	92.0	0.80	425	3.0	140	92.5	0.86	16.0	0.09	0.525	375
ARC 225 MX4	25.0	161	48.5	1485	91.0	0.82	480	3.0	145	89.0	0.82	20.0	0.09	0.638	420
ARC 250 S4	32.0	205	64.5	1490	93.0	0.77	624	3.0	181	92.5	0.86	31.5	0.07	0.950	520
ARC 250 M4	40.0	257	79.5	1485	93.0	0.78	778	3.0	245	93.7	0.86	33.5	0.08	1.100	580
ARC 280 S4	50.0	319	102.0	1495	93.5	0.76	968	3.0	330	95.0	0.85	40.0	0.08	1.960	830
ARC 280 M4	60.0	384	117.0	1492	94.0	0.79	1169	3.0	380	94.0	0.84	43.5	0.07	2.270	895
ARC 280 MX4	70.0	449	136.0	1490	94.0	0.79	1330	3.0	480	94.0	0.85	58.0	0.05	2.730	1015
ARC 315 M4	95.0	607	172.0	1495	96.0	0.83	1780	2.9	580	95.0	0.87	62.5	0.05	4.820	1300
ARC 315 L4	132.0	845	239.0	1492	96.0	0.83	2040	2.4	680	95.5	0.88	72.0	0.05	5.930	1450
ARC 315 LX4	150.0	961	268.0	1490	96.0	0.84	2884	3.0	980	95.5	0.88	98.0	0.04	6.820	1630
ARC 355 M4	160.0	1022	293.0	1495	95.0	0.83	3066	3.0	1050	95.0	0.79	127.0	0.05	10.000	2500
ARC 400 L4	240.0	1534	1494	data on request			6340	4.1						20.000	3210
ARC 400 LX 4	290.0	1854	1494	data on request			7500	4.0						25.000	3460

Synchronous speed 1000 rpm – 6-pole version															
ARC	P_{eff} (S1) kW	M_{eff} Nm	I_n 400 V A	n_n rpm	η_n referred to P_{eff} %	$\cos\varphi_n$ -	M_{max} Nm	M_{max}/M_{eff}	I_{max} A	η_{max} referred to M_{max} %	$\cos\varphi_{max}$ -	I_0 A	$\cos\varphi_0$ -	J kgm ²	m kg
ARC 112 M6	1.5	15	4.1	975	78.5	0.68	45	3.1	11	74.1	0.84	3.0	0.12	0.018	52
ARC 112 MX6	1.9	19	4.6	975	81.0	0.74	57	3.1	13	77.0	0.82	3.5	0.12	0.023	60
ARC 112 MZ6	2.2	22	5.6	970	81.0	0.70	66	3.1	15	74.0	0.84	4.2	0.10	0.029	62
ARC 132 S6	2.6	25	6.3	980	83.5	0.71	79	3.1	16	78.5	0.83	4.3	0.11	0.043	90
ARC 132 M6	3.5	34	9.3	980	82.5	0.66	103	3.0	24	83.6	0.77	6.5	0.11	0.053	95
ARC 132 MX6	4.2	41	10.5	978	84.0	0.70	130	3.2	28	82.8	0.80	7.0	0.11	0.066	110
ARC 160 S6	4.8	47	11.0	980	85.5	0.75	145	3.1	29	82.8	0.87	6.5	0.11	0.113	120
ARC 160 M6	6.5	63	14.0	985	86.0	0.79	195	3.1	40	84.0	0.84	7.7	0.13	0.145	145
ARC 160 L6	7.0	68	15.5	980	86.5	0.75	205	3.0	43	83.0	0.83	8.0	0.13	0.166	160
ARC 180 S6	7.6	74	15.0	985	89.5	0.81	228	3.1	46	85.6	0.87	7.9	0.15	0.228	190
ARC 180 M6	9.5	92	19.5	985	86.5	0.81	283	3.1	65	84.2	0.87	9.5	0.11	0.268	215
ARC 180 L6	11.0	107	23.0	985	86.0	0.80	320	3.0	70	84.0	0.85	12.0	0.12	0.324	250
ARC 200 M6	12.5	121	25.0	985	89.5	0.81	373	3.1	75	88.7	0.88	13.0	0.11	0.443	315
ARC 200 L6	15.0	145	30.0	985	89.5	0.80	450	3.1	90	88.5	0.88	14.0	0.11	0.514	330
ARC 200 LX6	19.5	189	37.5	985	90.0	0.83	580	3.1	115	88.7	0.88	20.0	0.11	0.620	360
ARC 225 M6	16.5	159	33.0	990	91.0	0.79	496	3.1	95	89.6	0.88	17.0	0.09	0.825	390
ARC 225 MX6	18.0	174		990			535	3.1						0.920	440
ARC 250 S6	22.0	212	43.0	991	91.0	0.81	540	2.5	110	90.7	0.88	24.0	0.08	1.280	465
ARC 250 M6	27.0	260	51.5	991	92.0	0.82	706	2.7	140	91.3	0.88	26.0	0.08	1.480	520
ARC 280 S6	37.0	356	71.5	992	93.5	0.83	1075	3.0	235	89.0	0.80	30.0	0.08	2.630	780
ARC 280 M6	44.0	423	84.0	993	93.5	0.81	1265	3.0	260	92.5	0.87	37.5	0.08	3.330	855
ARC 280 MX6	48.0	461	90.5	995	93.5	0.82	1608	3.5	320	92.5	0.86	45.0	0.07	3.600	890
ARC 315 M6	75.0	721	138.0	993	94.5	0.83	1945	2.7	380	93.9	0.87	55.0	0.06	6.000	1050
ARC 315 L6	90.0	866	164.0	993	94.5	0.84	2140	2.5	450	93.0	0.88	61.0	0.08	6.670	1250
ARC 315 LX6	100.0	962	183.0	993	95.0	0.83	2800	2.9	541	94.0	0.87	72.0	0.06	8.600	1460
ARC 355 M6	140.0	1344	263.0	995	96.0	0.80	4031	3.0	815	94.5	0.80	120.0	0.05	8.200	1650
ARC 355 MX6	160.0	1536	301.0	995	96.0	0.80	4607	3.0	885	96.5	0.80	147.0	0.04	12.800	2200
ARC 400 L6	210.0	2030		995			6400	3.2						25.000	3120
ARC 400 LX6	240.0	2310		995			7460	3.2						27.000	3340

Three-phase roller table motors with squirrel-cage rotor for converter-fed operation, series ARC

Non-ventilated with surface cooling, IC 410

Planning data for switched operation calculations/motor pre-selection

Duty type S9, thermal class F, type of protection IP 55, rated frequency 50 Hz

Insulation system for \dot{U} max. 1.35 kV; du/dt max. 1.5 kV/ μ s

ARC	Equivalent S1 output						Transient peak load (max. 10 s)					No-load			
	P_{eff} (S1) kW	M_{eff} Nm	I_n 400 V A	n_n referred to P_{eff} rpm	η_n %	$\cos\varphi_n$ -	M_{max} Nm	$M_{\text{max}}/M_{\text{eff}}$	I_{max} referred to M_{max} A	η_{max} %	$\cos\varphi_{\text{max}}$ -	I_0 A	$\cos\varphi_0$ -	J kgm ²	m kg
Synchronous speed 750 rpm – 8-pole version															
ARC 112 M8	1.1	14	4.1	725	72.5	0.54	38	2.6	7	71.0	0.78	3.5	0.11	0.018	46
ARC 112 MX8	1.5	20	4.7	725	75.5	0.61	54	2.7	10	72.3	0.81	3.8	0.11	0.023	53
ARC 112 MZ8	1.7	22	5.4	725	75.5	0.60	65	3.0	12	66.0	0.80	4.3	0.11	0.029	62
ARC 132 S8	1.8	24	5.3	730	78.5	0.62	57	2.4	12	77.5	0.78	4.2	0.11	0.043	90
ARC 132 M8	2.5	33	9.0	734	76.0	0.53	87	2.7	15	74.0	0.77	6.0	0.10	0.053	95
ARC 132 MX8	3.0	39	9.4	730	77.0	0.60	110	2.8	20	72.0	0.78	7.0	0.10	0.066	110
ARC 160 S8	3.6	47	9.2	735	83.5	0.68	117	2.5	20	81.0	0.78	6.5	0.10	0.113	120
ARC 160 M8	5.0	65	12.5	730	83.0	0.69	174	2.7	29	82.0	0.79	9.0	0.11	0.145	145
ARC 160 L8	6.5	84	17.5	735	83.0	0.65	225	2.7	38	82.0	0.79	12.0	0.08	0.166	160
ARC 180 S8	6.5	84	16.5	740	87.0	0.66	257	3.1	41	84.0	0.81	12.0	0.08	0.228	180
ARC 180 M8	7.5	97	19.5	740	86.0	0.65	316	3.3	49	86.0	0.82	15.0	0.09	0.268	215
ARC 180 L8	8.0	103	20.0	740	87.0	0.67	325	3.2	55	82.0	0.80	14.0	0.08	0.324	250
ARC 200 M8	9.0	116	20.5	740	87.5	0.72	390	3.4	62	86.0	0.84	13.0	0.09	0.443	315
ARC 200 L8	11.0	143	22.5	735	89.5	0.78	410	2.9	63	87.0	0.84	13.0	0.08	0.514	330
ARC 225 M8	13.0	167	28.0	743	86.3	0.78	480	2.9	74	88.8	0.80	19.0	0.08	0.825	390
ARC 225 MX8	14.0	180					540	3.0						0.920	440
ARC 250 S8	17.5	226	38.0	740	90.5	0.73	590	2.6	90	89.8	0.81	22.0	0.07	1.350	510
ARC 250 M8	22.0	284	47.5	740	90.5	0.74	715	2.5	118	90.7	0.77	28.0	0.07	1.550	560
ARC 280 S8	28.0	359	62.0	745	92.0	0.71	1040	2.9	190	91.8	0.79	36.0	0.06	2.63	780
ARC 280 M8	35.0	449	76.5	745	93.0	0.71	1320	2.9	250	91.6	0.81	48.0	0.06	3.33	855
ARC 280 MX8	37.0	474	82.0	746	92.0	0.71	1685	3.6	290	92.3	0.80	72.0	0.05	3.60	890
ARC 315 M8	55.0	710	113.0	741	93.6	0.75	2100	3.0	306	91.1	0.82	68.0	0.05	6.000	1050
ARC 315 L8	68.0	875	146.0	745	94.4	0.71	2140	2.4	309	94.1	0.82	90.0	0.05	6.760	1250
ARC 315 LX8	85.0	1090	176.0	745	93.0	0.75	2724	2.5	385	92.0	0.82	88.0	0.06	8.710	1460
ARC 355 M8	90.0	1154	187.0	745	94.0	0.74	3461	3.0	520	93.5	0.80	95.0	0.05	9.500	1600
ARC 355 MX8	110.0	1410	228.0	745	94.0	0.74	4230	3.0	630	94.0	0.80	115.0	0.05	13.400	2200
ARC 400 L8	170.0	2176		746	data on request		6450							32.000	3120
ARC 400 LX8	200.0	2560		746	data on request		7750							39.000	3460

Synchronous speed 600 rpm – 10-pole version															
ARC 112 M10	0.55	9		570	data on request		25	2.7						0.018	46
ARC 112 MX10	0.8	12	2.9	575	66.5	0.56	35	2.8	6	55.0	0.80			0.023	60
ARC 112 MZ10	0.85	14		570	data on request		40	2.8						0.029	62
ARC 132 S10	1.1	18		575	data on request		49	2.7						0.043	90
ARC 132 M10	1.5	25	5.2	575	78.0	0.53	60	2.4	10	80.0	0.65	4.5	0.09	0.053	95
ARC 132 MX10	1.8	30		575	data on request		75	2.5						0.066	110
ARC 160 S10	2.8	46		575	data on request		115	2.5						0.113	120
ARC 160 M10	3.0	50	8.7	575	80.0	0.62	120	2.4	18	80.0	0.75	6.5	0.11	0.145	145
ARC 160 L10	4.0	66		575	data on request		165	2.5						0.166	155
ARC 180 S10	4.5	73	15.5	590	82.0	0.50	225	3.0	33	82.0	0.75	12.5	0.07	0.228	180
ARC 180 M10	6.5	105	22.0	590	83.5	0.51	315	3.0	47	80.0	0.76			0.268	215
ARC 180 L10	7.0	116	20.5	575	83.0	0.59	300	2.6	44	81.5	0.75	16.0	0.09	0.324	340
ARC 200 M10	8.5	140		580	data on request		380	2.7						0.443	315
ARC 200 L10	9.0	148		580	data on request		400	2.7						0.514	330
ARC 225 M10	11.0	178	33.0	590	86.5	0.56	480	2.7	84	85.5	0.73	23.5	0.07	0.825	390
ARC 225 MX10	12.0	198		580	data on request		535	2.7						0.920	440
ARC 250 S10	13.5	220		585	data on request		595	2.7						1.280	510
ARC 250 M10	17.0	278		585	data on request		750	2.7						1.480	560
ARC 280 S10	22.5	364		590	data on request		980	2.7						2.630	780
ARC 280 M10	27.5	445		590	data on request		1200	2.7						3.330	855
ARC 280 MX10	37.5	607		590	data on request		1640	2.7						3.600	935
ARC 315 M10	45.0	722	143.0	595	92.5	0.49	2190	3.0	295	93.0	0.70			6.000	1050
ARC 315 L10	55.0	890		590	data on request		2670	3.0						6.670	1250
ARC 315 LX10				590	data on request									6.670	1460
ARC 355 M10	68.0	1091		595	data on request		3274	3.0						9.500	1600
ARC 355 MX10	80.0	1284		595	data on request		3852	3.0						13.400	2200

Three-phase roller table motors with squirrel-cage rotor for converter-fed operation, series ARC

Non-ventilated with surface cooling, IC 410

Planning data for switched operation calculations/motor pre-selection

Duty type S9, thermal class F, type of protection IP 55, rated frequency 50 Hz

Insulation system for \dot{U} max. 1.35 kV; du/dt max. 1.5 kV/ μ s

ARC	Equivalent S1 output						Transient peak load (max. 10 s)					No-load			
	P_{eff} (S1) kW	M_{eff} Nm	I_n 400 V A	n_n rpm	η_n referred to P_{eff} %	$\cos\varphi_n$ -	M_{max} Nm	$M_{\text{max}}/M_{\text{eff}}$	I_{max} A	η_{max} referred to M_{max} %	$\cos\varphi_{\text{max}}$ -	I_0 A	$\cos\varphi_0$ -	J kgm ²	m kg
Synchronous speed 500 rpm – 12-pole version															
ARC 112 M12	0.4	8		475	data on request		20	2.7						0.018	46
ARC 112 MX12	0.6	11		470	data on request		30	2.7						0.023	60
ARC 112 MZ12	0.7	14		470	data on request		40	2.8						0.029	62
ARC 132 S12	0.8	15		480	data on request		40	2.7						0.043	90
ARC 132 M12	1.1	22		480	data on request		60	2.7						0.053	95
ARC 132 MX12	1.3	26	7.5	485	66.0	0.38	67	2.6	12	74.0	0.60	8.0	0.11	0.053	110
ARC 160 S12	1.5	30		475	data on request		80	2.7						0.113	120
ARC 160 M12	2.75	54	13.5	488	71.0	0.42	160	3.0	24	79.5	0.64	12.6	0.10	0.145	145
ARC 160 L12	3.0	60		480	data on request		160	2.7						0.166	155
ARC 180 S12	3.0	60		480	data on request		160	2.7						0.228	180
ARC 180 M12	4.5	90	21.0	480	76.5	0.40	270	3.0	33			20.0	0.08	0.268	215
ARC 180 L12	5.5	109	24.0	480	81.5	0.41	330	3.0	70			19.5	0.07	0.324	340
ARC 200 M12	6.5	129		480	data on request		350	2.7						0.443	315
ARC 200 L12	7.0	139		480	data on request		375	2.7						0.514	330
ARC 225 M12	8.5	169	35.0	480	81.0	0.43	510	3.0	67			32.5	0.07	0.825	390
ARC 225 MX12	9.0	179		480	data on request		480	2.7						0.920	440
ARC 250 S12	10.0	199		480	data on request		535	2.7						1.280	510
ARC 250 M12	12.0	232	49.0	495	84.5	0.42	625	2.7						1.480	560
ARC 280 S12	18.5	364		485	data on request		985	2.7						2.630	780
ARC 280 M12	22.5	443		485	data on request		1195	2.7						3.330	855
ARC 280 MX12	27.5	541		485	data on request		1460	2.7						3.600	935
ARC 315 M12	37.5	738		485	data on request		1995	2.7						6.000	1050
ARC 315 L12				485	data on request									6.670	1250
ARC 315 LX12	45	886		485	data on request		2390	2.7						6.670	1460
ARC 355 M12	55	1072		490	data on request		2895	2.7						9.500	1600
ARC 355 MX12	66	1286		490	data on request		3475	2.7						13.400	2200
ARC 400 L12	110.00	2110		497	data on request		6000	2.8						37.000	3000
ARC 400L X12	132.00	2550		497	data on request		7320	2.9						45.000	3320

Three-phase roller table motors with squirrel-cage rotor for converter-fed operation, series ARC

Non-ventilated with surface cooling, IC 410

Planning data for switched operation calculations/motor pre-selection

Duty type S9, thermal class F, type of protection IP 55, rated frequency 50 Hz

Insulation system for \dot{U} max. 1.35 kV; du/dt max. 1.5 kV/ μ s

Transient peak load (max. 10 s)														
ARC	50 Hz			40 Hz			30 Hz			20 Hz			J	m
	M_{eff}	M_{max}	I_{eff} 400 V	M_{eff}	M_{max}	I_{eff} 400 V	M_{eff}	M_{max}	I_{eff} 400 V	M_{eff}	M_{max}	I_{eff} 400 V		
	Nm	Nm	A	Nm	Nm	A	Nm	Nm	A	Nm	Nm	A		
Synchronous speed	1500 rpm			1200 rpm			900 rpm			600 rpm				
ARC 112 M4	15	47	4.7	16	49	4.0	17	52	3.2	18	56	2.3	0.015	56
ARC 112 MX4	16	49		17	51		18	54		19	59		0.017	63
ARC 112 MZ4	20	60		21	63		22	66		24	72		0.020	67
ARC 132 S4	19	61	6.6	20	64	5.5	21	67	4.3	23	73	3.1	0.028	82
ARC 132 M4	28	93	9.2	29	98	7.5	31	102	6.0	34	112	4.4	0.035	95
ARC 132 MX4	40	120		42	126		44	132		48	144		0.044	105
ARC 160 S4	35	105	11.5	36	110	9.2	39	116	7.4	42	126	5.3	0.078	130
ARC 160 M4	50	150	16.0	52	158	13.2	55	165	10.5	60	180	7.6	0.090	144
ARC 160 MX4	52	160	16.5	54	168	13.9	57	176	11.0	62	192	8.0	0.104	150
ARC 160 L4	66	200	20.0	69	210	16.8	73	220	13.3	79	240	9.6	0.116	170
ARC 180 S4	57	175	18.5	59	184	15.3	63	193	12.3	68	210	8.8	0.138	170
ARC 180 M4	71	215	22.0	74	226	18.4	78	237	14.5	85	258	10.5	0.168	215
ARC 180 MX4	90	270		94	284		99	297		108	324		0.203	250
ARC 200 M4	100	307	29.5	104	322	25.5	110	338	20.2	120	368	14.7	0.275	270
ARC 200 L4	119	367	35.0	124	385	29.5	131	404	23.3	143	440	17.0	0.313	335
ARC 200 LX4	128	380	39.5	133	399	32.7	141	418	26.0	154	456	19.0	0.356	350
ARC 225 M4	141	425	43.0	147	446	35.9	155	468	28.4	169	510	20.6	0.525	375
ARC 225 MX4	161	480		167	504		177	528		193	576		0.638	420
ARC 250 S4	205	624	59.0	213	655	49.1	226	686	39.0	246	749	28.3	0.950	520
ARC 250 M4	257	778	73.0	267	817	60.6	283	856	48.2	308	934	35.0	1.100	580
ARC 280 S4	319	968	102.0	332	1016	84.5	351	1065	67.0	383	1162	48.7	1.960	830
ARC 280 M4	384	1169	117.0	399	1227	96.9	422	1286	76.9	461	1403	56.0	2.270	895
ARC 280 MX4	449	1330	136.0	467	1397	113.3	494	1463	89.9	539	1596	65.4	2.730	1015
ARC 315 M4	607	1780	172.0	631	1869	143.1	668	1958	113.7	728	2136	82.6	4.820	1300
ARC 315 L4	845	2040	239.0	879	2142	199.0	930	2244	157.9	1014	2448	114.8	5.930	1450
ARC 315 LX4	961	2884	268.0	1000	3028	223.4	1058	3172	177.3	1154	3461	128.9	6.820	1630
ARC 355 M4	1022	3066	291.0	1063	3219	243.7	1124	3373	193.3	1226	3679	140.5	10.000	2500
ARC 400 L4	1534	6340	415.0	1596	6657	344.8	1688	6974	273.5	1841	7608	198.9	20.000	3210
ARC 400 LX 4	1854	7500	500.0	1928	7875	416.1	2039	8250	330.1	2224	9000	240.0	25.000	3460

Synchronous speed	1000 rpm			800 rpm			600 rpm			400 rpm				
ARC 112 M6	15	45	4.1	15	47	3.3	16	50	2.7	18	54	2.0	0.018	52
ARC 112 MX6	19	57	4.6	19	60	3.7	20	63	3.0	22	68	2.2	0.023	60
ARC 112 MZ6	22	66		22	69		24	73		26	79		0.029	62
ARC 132 S6	25	79	6.3	26	83	5.2	28	87	4.2	30	95	3.0	0.043	90
ARC 132 M6	34	103	9.3	35	108	7.6	38	113	6.2	41	124	4.5	0.053	95
ARC 132 MX6	41	130	10.5	43	137	8.6	45	143	6.8	49	156	4.9	0.066	110
ARC 160 S6	47	145	11.0	49	152	9.1	51	160	7.1	56	174	5.2	0.113	120
ARC 160 M6	63	195	14.0	66	205	11.6	70	215	9.2	76	234	6.7	0.145	145
ARC 160 L6	68	205		71	215		75	226		82	246		0.166	155
ARC 180 S6	74	228	15.0	77	239	12.6	81	251	10.0	88	274	7.2	0.228	180
ARC 180 M6	92	283	19.5	96	297	16.4	101	311	12.9	111	340	9.5	0.268	215
ARC 180 MX6	107	320		111	336		117	352		128	384		0.324	340
ARC 200 M6	121	373	25.0	126	392	20.7	133	410	16.4	145	448	11.9	0.443	315
ARC 200 L6	145	450	30.0	151	473	25.1	160	495	20.0	175	540	14.6	0.514	330
ARC 200 LX6	189	580	37.0	197	609	31.0	208	638	24.6	227	696	17.9	0.620	360
ARC 225 M6	159	496	33.0	166	521	27.6	175	546	21.9	191	595	15.9	0.825	390
ARC 225 MX6	174	535		181	562		191	589		208	642		0.920	440
ARC 250 S6	212	540	43.0	220	567	35.9	233	594	28.5	254	648	20.7	1.280	465
ARC 250 M6	260	706	51.5	271	741	43.0	286	777	34.1	312	847	24.8	1.480	520
ARC 280 S6	356	1075	71.5	370	1129	59.5	392	1183	47.3	427	1290	34.4	2.630	780
ARC 280 M6	424	1265	83.0	441	1328	69.0	466	1392	54.7	508	1518	39.7	3.330	855
ARC 280 MX6	461	1608	90.5	479	1688	75.2	507	1769	59.7	553	1930	43.4	3.600	935
ARC 315 M6	721	1945	138.0	750	2042	114.8	793	2140	91.0	866	2334	66.3	6.000	1050
ARC 315 L6	866	2140	167.0	900	2247	139.2	952	2354	110.4	1039	2568	80.3	6.670	1250
ARC 315 LX6	960	2800	191.0	998	2940	158.8	1056	3080	126.0	1152	3360	91.7	8.600	1460
ARC 355 M6	1344	4031	263.0	1397	4233	218.8	1478	4434	173.6	1612	4837	126.3	8.200	1650
ARC 355 MX6	1536	4607	301.0	1597	4837	250.2	1689	5068	198.4	1843	5528	144.4	12.800	2200
ARC 400 L6	2030	6400	380.0	2111	6720	319.4	2233	7040	253.4	2436	7680	184.3	25.000	3120
ARC 400 LX6	2310	7460	440.0	2402	7833	367.9	2541	8206	291.9	2772	8952	212.3	27.000	3340

Three-phase roller table motors with squirrel-cage rotor for converter-fed operation, series ARC

Non-ventilated with surface cooling, IC 410

Planning data for switched operation calculations/motor pre-selection

Duty type S9, thermal class F, type of protection IP 55, rated frequency 50 Hz

Insulation system for \dot{U} max. 1.35 kV; du/dt max. 1.5 kV/μs

Transient peak load (max. 10 s)														
ARC	50 Hz			40 Hz			30 Hz			20 Hz			J	m
	M_{eff}	M_{max}	I_{eff} 400 V	M_{eff}	M_{max}	I_{eff} 400 V	M_{eff}	M_{max}	I_{eff} 400 V	M_{eff}	M_{max}	I_{eff} 400 V		
	Nm	Nm	A	Nm	Nm	A	Nm	Nm	A	Nm	Nm	A		
Synchronous speed	1500 rpm			1200 rpm			900 rpm			600 rpm				
ARC 112 M8	14	38	4.1	15	40	3.4	16	42	2.7	17	46	1.9	0.018	46
ARC 112 MX8	20	54	4.7	20	57	3.8	21	59	3.0	23	65	2.2	0.023	60
ARC 112 MZ8	22	65		23	68		24	72		26	78		0.029	62
ARC 132 S8	24	57	5.3	24	60	4.4	26	63	3.5	28	68	2.5	0.043	90
ARC 132 M8	33	87	9.0	34	91	7.5	36	96	5.9	39	104	4.3	0.053	95
ARC 132 MX8	39	110		41	116		43	121		47	132		0.066	110
ARC 160 S8	47	117	9.2	49	123	7.7	52	129	6.1	56	140	4.4	0.113	120
ARC 160 M8	65	174	12.5	68	183	10.5	72	191	8.3	78	209	6.0	0.145	145
ARC 160 L8	95	255		99	268		105	281		114	306		0.166	155
ARC 180 S8	84	257	16.5	87	270	13.6	92	283	10.8	101	308	7.9	0.228	180
ARC 180 M8	97	316	19.5	101	332	16.2	107	348	12.8	116	379	9.3	0.268	215
ARC 180 MX8	103	325		107	341		113	358		124	390		0.324	340
ARC 200 M8	116	390	20.5	121	410	17.2	128	429	13.6	139	468	9.9	0.443	315
ARC 200 L8	143	410	22.5	149	431	19.0	157	451	15.0	172	492	10.9	0.514	330
ARC 225 M8	167	480	28.0	174	504	23.2	184	528	18.4	200	576	13.3	0.825	390
ARC 225 MX8	180	540		187	567		198	594		216	648		0.920	440
ARC 250 S8	226	590	38.0	235	620	31.8	249	649	25.3	271	708	18.4	1.350	510
ARC 250 M8	284	715	47.5	295	751	39.4	312	787	31.3	341	858	22.8	1.550	560
ARC 280 S8	359	1040	62.0	373	1092	51.4	395	1144	40.9	431	1248	29.7	2.63	780
ARC 280 M8	449	1320	76.5	467	1386	63.7	494	1452	50.5	538	1584	36.7	3.33	855
ARC 280 L8	474	1685	82.0	493	1769	68.1	521	1854	54.0	568	2022	39.2	3.60	935
ARC 315 M8	710	2100	113.0	738	2205	94.2	781	2310	74.8	852	2520	54.4	6.000	1050
ARC 315 L8	875	2140	145.0	910	2247	122.3	963	2354	97.1	1050	2568	70.6	6.760	1250
ARC 315 LX8	1090	2724		1133	2860		1199	2996		1308	3269		8.710	1460
ARC 355 M8	1154	3461	145.0	1200	3634	155.4	1269	3807	123.2	1384	4153	89.6	9.500	1600
ARC 355 MX8	1410	4230	145.0	1466	4442	189.8	1551	4653	150.6	1692	5076	109.6	13.400	2200
ARC 400 L8	2176	6450	345.0	2263	6773	286.5	2394	7095	227.3	2612	7740	165.3	32.000	3120
ARC 400 LX8	2560	7750	405.0	2663	8138	336.8	2816	8525	267.1	3072	9300	194.2	39.000	3460

Three-phase roller table motors with squirrel-cage rotor for converter-fed operation, series ARC

Non-ventilated with surface cooling, IC 410

Planning data for switched operation calculations/motor pre-selection

Duty type S9, thermal class F, type of protection IP 55, rated frequency 50 Hz

Insulation system for \dot{U} max. 1.8 kV; du/dt max. 5 kV/ μ s

ARC	Equivalent S1 output						Transient peak load (max. 10 s)					No-load			
	P_{eff} (S1) kW	M_{eff} Nm	I_n 500 V A	n_n rpm	η_n referred to P_{eff} %	$\cos\varphi_n$ -	M_{max} Nm	$M_{\text{max}}/M_{\text{eff}}$	I_{max} referred to M_{max} A	η_{max} %	$\cos\varphi_{\text{max}}$ -	I_0 A	$\cos\varphi_0$ -	J kgm ²	m kg
Synchronous speed 1500 rpm – 4-pole version															
ARC 112 M4 TU	2.3	15	3.8	1460	83.5	0.84	43	2.9	10	78.0	0.86	2.0	0.12	0.015	56
ARC 112 MX4 TU	2.5	16	4.0	1465	84.0	0.85	46	2.8	15	77.0	0.87	2.1	0.11	0.017	63
ARC 112 MZ4 TU	2.8	18	4.5	1470	85.0	0.84	55	3.0	17	69.0	0.87	3.3	0.11	0.020	67
ARC 132 S4 TU	3.0	19	5.2	1475	85.0	0.81	61	3.1	16	84.0	0.81	2.9	0.12	0.028	82
ARC 132 M4 TU	4.4	28	7.4	1475	87.0	0.79	93	3.3	24	82.0	0.89	4.5	0.10	0.035	95
ARC 132 MX4 TU	5.5	36	9.1	1470	87.0	0.80	110	3.1	27	80.0	0.87	4.8	0.10	0.044	105
ARC 160 S4 TU	5.5	35	8.8	1480	88.0	0.82	105	3.0	28	82.0	0.85	5.0	0.13	0.078	130
ARC 160 M4 TU	7.7	50	12.5	1480	89.0	0.79	150	3.0	42	85.0	0.84	8.5	0.11	0.090	144
ARC 160 MX4 TU	8.0	52	13.5	1480	89.5	0.77	160	3.1	50	85.0	0.83	7.5	0.11	0.104	160
ARC 160 L4 TU	10.2	66	16.0	1480	88.5	0.83	200	3.0	55	86.0	0.85	8.0	0.13	0.116	170
ARC 180 S4 TU	8.8	57	15.0	1480	86.0	0.80	175	3.1	44	84.5	0.83	10.0	0.07	0.138	170
ARC 180 M4 TU	11.0	71	17.5	1485	90.5	0.80	215	3.0	58	90.0	0.85	12.5	0.07	0.168	215
ARC 180 L4 TU	14.0	90	22.0	1480	91.0	0.82	270	3.0	79	88.0	0.85	13.5	0.10	0.203	250
ARC 200 M4 TU	15.0	100	24.0	1475	91.0	0.80	307	3.1	76	91.1	0.85	12.5	0.08	0.275	270
ARC 200 L4 TU	18.5	119	28.0	1485	92.5	0.82	367	3.1	87	91.5	0.82	13.5	0.09	0.313	335
ARC 200 LX4 TU	20.0	128	31.5	1485	91.5	0.80	380	3.0	97	83.0	0.84	17.0	0.09	0.356	350
ARC 225 M4 TU	22.0	141	34.5	1485	92.0	0.80	425	3.0	112	92.5	0.86	13.5	0.09	0.525	375
ARC 225 MX4 TU	25.0	161	38.5	1485	91.0	0.82	480	3.0	116	89.0	0.82	16.5	0.09	0.638	420
ARC 250 S4 TU	32.0	205	51.5	1490	93.0	0.77	624	3.0	145	92.5	0.86	26.3	0.07	0.950	520
ARC 250 M4 TU	40.0	257	63.5	1485	93.0	0.78	778	3.0	196	93.7	0.86	28.0	0.08	1.100	580
ARC 280 S4 TU	50.0	319	81.0	1495	93.5	0.76	968	3.0	264	95.0	0.85	33.5	0.08	1.960	830
ARC 280 M4 TU	60.0	384	93.5	1492	94.0	0.79	1169	3.0	304	94.0	0.84	36.5	0.07	2.270	895
ARC 280 MX4 TU	70.0	449	109.0	1490	94.0	0.79	1330	3.0	384	94.0	0.85	48.5	0.05	2.730	1015
ARC 315 M4 TU	95.0	607	138.0	1495	96.0	0.83	1780	2.9	464	95.0	0.87	52.0	0.05	4.820	1300
ARC 315 L4 TU	132.0	845	191.0	1492	96.0	0.83	2040	2.4	544	95.5	0.88	60.0	0.05	5.930	1450
ARC 315 LX4 TU	150.0	961	215.0	1490	96.0	0.84	2884	3.0	784	95.5	0.88	82.0	0.04	6.820	1630
ARC 355 M4 TU	160.0	1022	234.0	1495	95.0	0.83	3066	3.0	850	95.0	0.79	106.0	0.05	10.000	2500
ARC 400 L4 TU	240.0	1534		1494	data on request		6340	4.1						20.000	3210
ARC 400 LX 4 TU	290.0	1854		1494	data on request		7500	4.0						25.000	3460

Synchronous speed 1000 rpm – 6-pole version															
ARC	P_{eff}	M_{eff}	I_n	n_n	η_n	$\cos\varphi_n$	M_{max}	$M_{\text{max}}/M_{\text{eff}}$	I_{max}	η_{max}	$\cos\varphi_{\text{max}}$	I_0	$\cos\varphi_0$	J	m
ARC 112 M6 TU	1.5	15	3.3	975	77.0	0.69	52	2.9	9	74.1	0.84	2.4	0.12	0.018	52
ARC 112 MX6 TU	1.9	19	3.9	975	78.0	0.73	50	2.7	10	77.0	0.82	2.7	0.12	0.023	60
ARC 112 MZ6 TU	2.2	22	4.2	970	81.0	0.74	60	2.8	11	74.0	0.84	3.1	0.11	0.029	62
ARC 132 S6 TU	2.6	25	5.7	980	80.0	0.66	79	3.1	14	76.0	0.85	4.2	0.13	0.043	90
ARC 132 M6 TU	3.5	34	6.5	975	81.0	0.77	103	3.1	19	83.6	0.77	4.5	0.13	0.053	95
ARC 132 MX6 TU	4.2	41	8.0	975	83.0	0.73	130	3.0	23	82.8	0.80	5.0	0.11	0.066	110
ARC 160 S6 TU	4.8	47	8.6	980	85.5	0.75	145	3.1	25	82.8	0.87	5.5	0.11	0.113	120
ARC 160 M6 TU	6.5	63	11.0	980	86.0	0.78	195	3.1	32	84.0	0.84	6.5	0.12	0.145	145
ARC 160 L6 TU	7.0	68	12.5	980	85.5	0.75	205	3.0	35	83.0	0.81	6.7	0.13	0.166	160
ARC 180 S6 TU	7.6	73	12.5	980	85.5	0.82	200	2.7	32	84.0	0.88	6.5	0.15	0.228	180
ARC 180 M6 TU	9.5	92	16.0	985	86.5	0.80	283	3.1	48	84.2	0.87	8.0	0.12	0.268	215
ARC 180 L6 TU	11.0	107	18.5	985	86.0	0.80	320	3.0	56	84.0	0.85	10.0	0.12	0.324	250
ARC 200 M6 TU	12.5	121	20.0	985	89.5	0.81	373	3.1	60	88.7	0.88	11.0	0.11	0.443	315
ARC 200 L6 TU	15.0	145	24.0	985	89.5	0.80	450	3.1	72	88.5	0.88	12.0	0.11	0.514	330
ARC 200 LX6 TU	19.5	189	31.0	985	90.0	0.83	580	3.1	92	88.7	0.88	17.0	0.12	0.620	360
ARC 225 M6 TU	16.5	159	26.5	990	91.0	0.79	496	3.1	76	89.6	0.88	14.0	0.09	0.825	390
ARC 225 MX6 TU	18.0	174		990			535	3.1						0.920	440
ARC 250 S6 TU	22.0	212	34.5	991	91.0	0.81	540	2.5	88	90.7	0.88	20.0	0.08	1.280	465
ARC 250 M6 TU	27.0	260	41.5	991	92.0	0.82	706	2.7	112	91.3	0.88	22.0	0.08	1.480	520
ARC 280 S6 TU	37.0	356	71.5	992	93.5	0.83	1075	3.0	235	89.0	0.80	30.0	0.08	2.630	780
ARC 280 M6 TU	44.0	424	66.5	992	93.5	0.82	1265	3.0	208	92.5	0.87	34.0	0.07	3.330	855
ARC 280 MX6 TU	48.0	461	72.5	995	93.5	0.82	1608	3.5	256	92.5	0.86	37.5	0.07	3.600	890
ARC 315 M6 TU	75.0	721	110.0	993	94.5	0.83	1945	2.7	304	93.9	0.87	46.0	0.06	6.000	1050
ARC 315 L6 TU	90.0	866	131.0	993	94.5	0.84	2140	2.5	360	93.0	0.88	51.0	0.08	6.670	1250
ARC 315 LX6 TU	100.0	962	146.0	993	95.0	0.83	2800	2.9	433	94.0	0.87	60.0	0.06	8.600	1460
ARC 355 M6 TU	140.0	1344	210.0	995	96.0	0.80	4031	3.0	652	94.5	0.80	100.0	0.05	8.200	1650
ARC 355 MX6 TU	160.0	1536	241.0	995	96.0	0.80	4607	3.0	708	96.5	0.80	123.0	0.04	12.800	2200
ARC 400 L6 TU	210.0	2030		995	data on request		6400	3.2						25.000	3120
ARC 400 LX6 TU	240.0	2310		995	data on request		7460	3.2						27.000	3340

Three-phase roller table motors with squirrel-cage rotor for converter-fed operation, series ARC

Non-ventilated with surface cooling, IC 410

Planning data for switched operation calculations/motor pre-selection

Duty type S9, thermal class F, type of protection IP 55, rated frequency 50 Hz

Insulation system for \dot{U} max. 1.8 kV; du/dt max. 5 kV/ μ s

ARC	Equivalent S1 output						Transient peak load (max. 10 s)					No-load			
	P_{eff} (S1) kW	M_{eff} Nm	I_n 500 V A	n_n rpm	η_n referred to P_{eff} %	$\cos\varphi_n$ -	M_{max} Nm	M_{max}/M_{eff}	I_{max} referred to M_{max} A	η_{max} %	$\cos\varphi_{max}$ -	I_0 A	$\cos\varphi_0$ -	J kgm ²	m kg
Synchronous speed 750 rpm – 8-pole version															
ARC 112 M8 TU	0.9	12	2.7	725	70.5	0.55	32	2.7	8	70.0	0.79	2.3	0.13	0.018	46
ARC 112 MX8 TU	1.3	17	3.2	725	73.5	0.63	45	2.6	9	71.5	0.82	2.6	0.13	0.023	53
ARC 112 MZ8 TU	1.5	20	3.7	720	74.5	0.63	48	2.4	10	64.0	0.81	3.0	0.12	0.029	62
ARC 132 S8 TU	1.8	24	4.4	730	75.0	0.63	57	2.4	10	77.5	0.78	3.0	0.11	0.043	90
ARC 132 M8 TU	2.5	33	6.0	730	74.5	0.65	87	2.7	13	74.0	0.77	4.5	0.11	0.053	95
ARC 132 MX8 TU	3.0	39	7.7	730	75.0	0.60	110	2.8	16	72.0	0.78	6.0	0.11	0.066	110
ARC 160 S8 TU	3.6	47	7.6	735	83.0	0.66	117	2.5	25	81.0	0.78	6.5	0.10	0.113	120
ARC 160 M8 TU	5.0	65	10.5	735	83.5	0.65	174	2.7	23	79.0	0.80	7.5	0.10	0.145	145
ARC 160 L8 TU	6.5	85	13.5	730	83.0	0.66	225	2.6	31	78.0	0.79	9.0	0.09	0.166	160
ARC 180 S8 TU	6.5	84	13.0	740	87.0	0.66	257	3.1	33	84.0	0.81	10.0	0.08	0.228	190
ARC 180 M8 TU	7.5	97	15.5	740	86.0	0.65	316	3.3	39	86.0	0.82	12.5	0.09	0.268	215
ARC 180 L8 TU	8.0	103	16.0	740	87.0	0.67	325	3.2	44	82.0	0.80	11.5	0.08	0.324	250
ARC 200 M8 TU	9.0	116	16.5	740	87.5	0.72	390	3.4	50	86.0	0.84	11.0	0.09	0.443	315
ARC 200 L8 TU	11.0	143	18.0	735	89.5	0.78	410	2.9	51	87.0	0.84	11.0	0.08	0.514	330
ARC 225 M8 TU	13.0	167	22.5	743	86.3	0.78	480	2.9	60	88.8	0.80	17.0	0.08	0.825	390
ARC 225 MX8 TU	14.0	180					540	3.0						0.920	440
ARC 250 S8 TU	17.5	226	30.5	740	90.5	0.73	590	2.6	72	89.8	0.81	18.5	0.07	1.350	510
ARC 250 M8 TU	22.0	284	38.0	740	90.5	0.74	715	2.5	95	90.7	0.77	24.0	0.07	1.550	560
ARC 280 S8 TU	28.0	359	49.5	745	92.0	0.71	1040	2.9	152	91.8	0.79	30.0	0.06	2.63	780
ARC 280 M8 TU	35.0	449	61.0	745	93.0	0.71	1320	2.9	200	91.6	0.81	40.0	0.06	3.33	855
ARC 280 MX8 TU	37.0	474	65.5	746	92.0	0.71	1685	3.6	232	92.3	0.80	60.0	0.05	3.60	890
ARC 315 M8 TU	55.0	710	90.5	741	93.6	0.75	2100	3.0	245	91.1	0.82	57.0	0.05	6.000	1050
ARC 315 L8 TU	68.0	875	117.0	745	94.4	0.71	2140	2.4	248	94.1	0.82	75.0	0.05	6.760	1250
ARC 315 LX8 TU	85.0	1090	141.0	745	93.0	0.75	2724	2.5	308	92.0	0.82	73.5	0.06	8.710	1460
ARC 355 M8 TU	90.0	1154	149.0	745	94.0	0.74	3461	3.0	416	93.5	0.80	79.0	0.05	9.500	1600
ARC 355 MX8 TU	110.0	1410	183.0	745	94.0	0.74	4230	3.0	504	94.0	0.80	96.0	0.05	13.400	2200
ARC 400 L8 TU	170.0	2176		746		data on request	6450							32.000	3120
ARC 400 LX8 TU	200.0	2560		746		data on request	7750							39.000	3460

Synchronous speed 600 rpm – 10-pole version															
ARC 112 M10 TU	0.45	8		570		data on request	22	2.7						0.018	46
ARC 112 MX10 TU	0.61	10		575		data on request	28	2.8						0.023	60
ARC 112 MZ10 TU	0.70	12		570		data on request	33	2.8						0.029	62
ARC 132 S10 TU	1.0	17		575		data on request	46	2.7						0.043	90
ARC 132 M10 TU	1.30	22		575		data on request	60	2.5						0.053	95
ARC 132 MX10 TU	1.6	27		575		data on request	67	2.5						0.066	110
ARC 160 S10 TU	2.8	46		575		data on request	115	2.5						0.113	120
ARC 160 M10 TU	3.00	50	8.7	575	80.0	0.62	120	2.4	18	80.0	0.75	6.5	0.11	0.145	145
ARC 160 L10 TU	4.0	66		575		data on request	165	2.5						0.166	155
ARC 180 S10 TU	4.50	73	15.5	590	82.0	0.50	225	3.0	33	82.0	0.75	12.5	0.07	0.228	180
ARC 180 M10 TU	6.50	105	22.0	590	83.5	0.51	315	3.0	47	80.0	0.76			0.268	215
ARC 180 L10 TU	7.00	116	20.5	575	83.0	0.59	300	2.6	44	81.5	0.75	16.0	0.09	0.324	340
ARC 200 M10 TU	8.5	140		580		data on request	380	2.7						0.443	315
ARC 200 L10 TU	9.0	148		580		data on request	400	2.7						0.514	330
ARC 225 M10 TU	11.0	178	33.0	590	86.5	0.56	480	2.7	84	85.5	0.73	23.5	0.07	0.825	390
ARC 225 MX10 TU	12.0	198		580		data on request	535	2.7						0.920	440
ARC 250 S10 TU	13.5	220		585		data on request	595	2.7						1.280	510
ARC 250 M10 TU	17.0	278		585		data on request	750	2.7						1.480	560
ARC 280 S10 TU	22.5	364		590		data on request	980	2.7						2.630	780
ARC 280 M10 TU	27.5	445		590		data on request	1200	2.7						3.330	855
ARC 280 MX10 TU	37.5	607		590		data on request	1640	2.7						3.600	935
ARC 315 M10 TU	45.0	722	143.0	595	92.5	0.49	2190	3.0	295	93.0	0.70			6.000	1050
ARC 315 L10 TU	55.0	890		590		data on request	2670	3.0						6.670	1250
ARC 315 LX10 TU				590		data on request								6.670	1460
ARC 355 M10 TU	68.0	1091		595		data on request	3274	3.0						9.500	1600
ARC 355 MX10 TU	80.0	1284		595		data on request	3852	3.0						13.400	2200

Three-phase roller table motors with squirrel-cage rotor for converter-fed operation, series ARC

Non-ventilated with surface cooling, IC 410

Planning data for switched operation calculations/motor pre-selection

Duty type S9, thermal class F, type of protection IP 55, rated frequency 50 Hz

Insulation system for \dot{U} max. 1.8 kV; du/dt max. 5 kV/ μ s

ARC	Equivalent S1 output						Transient peak load (max. 10 s)					No-load			
	P_{eff} (S1) kW	M_{eff} Nm	I_n 500 V A	n_n rpm	η_n referred to P_{eff} %	$\cos\varphi_n$ -	M_{max} Nm	$M_{\text{max}}/M_{\text{eff}}$	I_{max} A	η_{max} referred to M_{max} %	$\cos\varphi_{\text{max}}$ -	I_0 A	$\cos\varphi_0$ -	J kgm ²	m kg
Synchronous speed 500 rpm – 12-pole version															
ARC 112 M12 TU	0.3	6		475	data on request		16	2.7						0.018	46
ARC 112 MX12 TU	0.5	10		470	data on request		27	2.7						0.023	60
ARC 112 MZ12 TU	0.6	12		470	data on request		33	2.8						0.029	62
ARC 132 S12 TU	0.8	16		480	data on request		43	2.7						0.043	90
ARC 132 M12 TU	1.0	20		480	data on request		54	2.7						0.053	95
ARC 132 MX12 TU	1.2	24		485	data on request		65	2.7						0.053	110
ARC 160 S12 TU	1.5	30		475	data on request		80	2.7						0.113	120
ARC 160 M12 TU	2.75	54	10.5	488	71.0	0.42	160	3.0	24	79.5	0.64	12.6	0.10	0.145	145
ARC 160 L12 TU	3.0	60		480	data on request		160	2.7						0.166	155
ARC 180 S12 TU	3.0	60		480	data on request		160	2.7						0.228	180
ARC 180 M12 TU	4.5	90	17.0	480	76.5	0.40	270	3.0	33			20.0	0.08	0.268	215
ARC 180 L12 TU	5.5	109	19.0	480	81.5	0.41	330	3.0	70			19.5	0.07	0.324	340
ARC 200 M12 TU	6.5	129		480	data on request		350	2.7						0.443	315
ARC 200 L12 TU	7.0	139		480	data on request		375	2.7						0.514	330
ARC 225 M12 TU	8.5	169	28.0	480	81.0	0.43	510	3.0	67			32.5	0.07	0.825	390
ARC 225 MX12 TU	9.0	179		480	data on request		480	2.7						0.920	440
ARC 250 S12 TU	10.0	199		480	data on request		535	2.7						1.280	510
ARC 250 M12 TU	12.0	232	39.0	495	84.5	0.42	625	2.7						1.480	560
ARC 280 S12 TU	18.5	364		485	data on request		985	2.7						2.630	780
ARC 280 M12 TU	22.5	443		485	data on request		1195	2.7						3.330	855
ARC 280 MX12 TU	27.5	541		485	data on request		1460	2.7						3.600	935
ARC 315 M12 TU	37.5	738		485	data on request		1995	2.7						6.000	1050
ARC 315 L12 TU				485	data on request									6.670	1250
ARC 315 LX12 TU	45	886		485	data on request		2390	2.7						6.670	1460
ARC 355 M12 TU	55	1072		490	data on request		2895	2.7						9.500	1600
ARC 355 MX12 TU	66	1286		490	data on request		3475	2.7						13.400	2200
ARC 400 L12 TU	110.00	2110	240	497	93.0	0.57	6000	2.8	630	93.5	0.74	215.0	0.04	37.000	3000
ARC 400 LX12 TU	132.00	2550	287	497	93.0	0.57	7320	2.9	770	92.4	0.75	260.0	0.04	45.000	3320

Three-phase roller table motors with squirrel-cage rotor for converter-fed operation, series ARC

Non-ventilated with surface cooling, IC 410

Planning data for switched operation calculations/motor pre-selection

Duty type S9, thermal class F, type of protection IP 55, rated frequency 50 Hz

Insulation system for \dot{U} max. 2.5 kV; du/dt max. 5 kV/ μ s

ARC	Equivalent S1 output						Transient peak load (max. 10 s)					No-load			
	P_{eff} (S1) kW	M_{eff} Nm	I_n 690 V A	n_n rpm	η_n referred to P_{eff} %	$\cos\varphi_n$ -	M_{max} Nm	$M_{\text{max}}/M_{\text{eff}}$	I_{max} referred to M_{max} A	η_{max} %	$\cos\varphi_{\text{max}}$ -	I_0 A	$\cos\varphi_0$ -	J kgm ²	m kg
Synchronous speed 1500 rpm – 4-pole version															
ARC 112 M4 TV	1.5	10	1.8	1470	82.0	0.85	27	2.8	5	69.5	0.90	1.1	0.13	0.015	56
ARC 112 MX4 TV	1.9	12		1478			43	3.5						0.017	63
ARC 112 MZ4 TV	2.3	15		1475			52	3.5						0.020	67
ARC 132 S4 TV	2.5	16	3.4	1477	82.0	0.76	49	3.0	10	75.0	0.89	2.0	0.14	0.028	82
ARC 132 M4 TV	3.5	23	4.4	1477	84.5	0.78	70	3.1	12	80.0	0.90	2.6	0.12	0.035	95
ARC 132 MX4 TV	4.4	28		1475			90	3.2						0.044	105
ARC 160 S4 TV	4.4	28	5.4	1480	86.0	0.80	90	3.2	16	84.0	0.85	3.2	0.15	0.078	130
ARC 160 M4 TV	5.5	35	6.7	1480	87.5	0.79	105	3.0	19	85.0	0.85	3.5	0.13	0.090	144
ARC 160 MX4 TV	6.5	42	8.0	1480	87.0	0.78	125	3.0	23	83.0	0.83	4.5	0.12	0.104	150
ARC 160 L4 TV	7.5	48	8.6	1480	87.0	0.84	150	3.1	26	86.0	0.84	4.0	0.16	0.116	170
ARC 180 S4 TV	8.0	51	9.5	1485	90.0	0.78	160	3.1	28	87.0	0.85	5.0	0.08	0.138	170
ARC 180 M4 TV	10.0	64	12.0	1485	89.0	0.78	190	3.0	33	87.0	0.85	7.0	0.10	0.168	215
ARC 180 L4 TV	12.0	77		1480			230	3.0						0.203	250
ARC 200 M4 TV	14.0	90	15.5	1485	91.5	0.82	270	3.0	46	88.0	0.85	7.5	0.09	0.275	270
ARC 200 L4 TV	15.0	96	16.5	1485	92.0	0.82	285	3.0	49	88.0	0.84	8.0	0.09	0.313	335
ARC 200 LX4 TV	18.5	119	22.0	1490	90.0	0.79	365	3.1	64	88.0	0.84	10.5	0.10	0.356	350
ARC 225 M4 TV	20.0	129	22.5	1485	92.0	0.81	380	3.0	67	89.0	0.84	10.5	0.08	0.525	375
ARC 225 MX4 TV	22.0	141		1485			425	3.0						0.638	420
ARC 250 S4 TV	25.0	160	29.0	1490	92.5	0.78	480	3.0	85	91.0	0.79	13.0	0.09	0.950	520
ARC 250 M4 TV	32.0	205	38.5	1490	93.0	0.75	624	3.0	110	92.5	0.79	19.0	0.07	1.100	580
ARC 280 S4 TV	40.0	256	45.5	1490	93.0	0.79	778	3.0	139	93.0	0.80	22.5	0.06	1.960	830
ARC 280 M4 TV	50.0	320	55.0	1490	93.5	0.81	968	3.0	175	92.0	0.78	24.0	0.07	2.270	895
ARC 280 MX4 TV	60.0	385	68.5	1490	93.0	0.79	1169	3.0	199	91.0	0.85	34.0	0.06	2.730	1015
ARC 315 M4 TV	70.0	449	72.5	1490	95.0	0.85	1330	3.0	280	93.0	0.80	25.5	0.07	4.820	1300
ARC 315 L4 TV	95.0	607	98.0	1495	95.5	0.85	1780	2.9	310	93.0	0.80	30.0	0.06	5.930	1450
ARC 315 LX4 TV	110.0	705	112.0	1490	95.5	0.86	2040	2.9	350	93.0	0.81	36.0	0.06	6.820	1630
ARC 355 M4 TV	132.0	843	134.0	1495	95.5	0.86	2530	3.0	430	84.5	0.80	56.0	0.06	10.000	2500
ARC 400 L4 TV	150.0	959		1494		data on request	6340	4.1						20.000	3210
ARC 400 LX 4 TV	160.0	1023		1494		data on request	7500	4.0						25.000	3460

Synchronous speed 1000 rpm – 6-pole version															
ARC 112 M6 TV	1.0	10	1.9	980	68.5	0.63	27	2.7	5	63.0	0.87	1.7	0.15	0.018	52
ARC 112 MX6 TV	1.3	13	2.3	980	73.0	0.64	38	3.0	6	65.0	0.87	1.9	0.13	0.023	60
ARC 112 MZ6 TV	1.7	17		975			43	2.6						0.029	62
ARC 132 S6 TV	2.2	21	3.5	985	77.0	0.68	66	3.1	10	69.0	0.83	2.7	0.13	0.043	90
ARC 132 M6 TV	2.6	25	3.8	980	78.0	0.73	79	3.1	11	71.0	0.85	2.6	0.16	0.053	95
ARC 132 MX6 TV	3.5	34	5.1	975	81.5	0.71	103	3.0	14	73.5	0.84	3.5	0.12	0.066	110
ARC 160 S6 TV	4.2	41	5.9	980	82.0	0.73	130	3.2	17	76.0	0.87	3.8	0.13	0.113	120
ARC 160 M6 TV	4.8	47	7.0	985	82.0	0.70	145	3.1	18	80.0	0.87	4.3	0.15	0.145	145
ARC 160 L6 TV	5.5	54	7.4	980	83.5	0.74	160	3.0	20	80.0	0.88	4.0	0.15	0.166	155
ARC 180 S6 TV	7.0	68	8.8	985	84.5	0.79	205	3.0	25	80.0	0.88	4.2	0.13	0.228	180
ARC 180 M6 TV	7.6	74	9.4	985	85.0	0.80	228	3.1	27	79.5	0.88	5.6	0.13	0.268	215
ARC 180 L6 TV	8.5	82	10.5	985	85.0	0.80	250	3.0	31	77.0	0.88	6.3	0.12	0.324	340
ARC 200 M6 TV	11.0	107	13.5	985	86.0	0.80	320	3.0	37	84.0	0.88	7.0	0.13	0.443	315
ARC 200 L6 TV	12.5	121	14.5	985	88.0	0.82	373	3.1	43	83.0	0.88	7.5	0.13	0.514	330
ARC 200 LX6 TV	15.0	145	17.0	985	88.0	0.85	450	3.1	66	83.0	0.88	12.0	0.11	0.620	360
ARC 225 M6 TV	15.0	145	17.5	990	89.0	0.81	450	3.1	55	84.0	0.85	9.0	0.09	0.825	390
ARC 225 MX6 TV	16.5	159		990			535	3.4						0.920	440
ARC 250 S6 TV	22.0	212	34.5	991	91.0	0.81	540	2.5	88	90.7	0.88		0.08	1.280	465
ARC 250 M6 TV	27.0	260	41.5	991	92.0	0.82	706	2.7	112	91.3	0.88	22.0	0.08	1.480	520
ARC 280 S6 TV	37.0	356	57.5	992	94.0	0.79	1075	3.0	184	93.1	0.88	27.0	0.05	2.630	780
ARC 280 M6 TV	44.0	424	66.5	992	93.5	0.82	1265	3.0	208	92.5	0.87	34.0	0.07	3.330	855
ARC 280 MX6 TV	48.0	461	72.5	995	93.5	0.82	1608	3.5	256	92.5	0.86	37.5	0.07	3.600	890
ARC 315 M6 TV	75.0	721	110.0	993	94.5	0.83	1945	2.7	304	93.9	0.87	46.0	0.06	6.000	1050
ARC 315 L6 TV	90.0	866	131.0	993	94.5	0.84	2140	2.5	360	93.0	0.88	51.0	0.08	6.670	1250
ARC 315 LX6 TV	100.0	962	146.0	993	95.0	0.83	2800	2.9	433	94.0	0.87	60.0	0.06	8.600	1460
ARC 355 M6 TV	140.0	1344	210.0	995	96.0	0.80	4031	3.0	652	94.5	0.80	100.0	0.05	8.200	1650
ARC 355 MX6 TV	160.0	1536	241.0	995	96.0	0.80	4607	3.0	708	96.5	0.80	123.0	0.04	12.800	2200
ARC 400 L6 TV	210.0	2030		995		data on request	6400	3.2						25.000	3120
ARC 400 LX6 TV	240.0	2310		995		data on request	7460	3.2						27.000	3340

Three-phase roller table motors with squirrel-cage rotor for converter-fed operation, series ARC

Non-ventilated with surface cooling, IC 410

Planning data for switched operation calculations/motor pre-selection

Duty type S9, thermal class F, type of protection IP 55, rated frequency 50 Hz

Insulation system for \dot{U} max. 2.5 kV; du/dt max. 5 kV/ μ s

ARC	Equivalent S1 output						Transient peak load (max. 10 s)					No-load			
	P_{eff} (S1) kW	M_{eff} Nm	I_n 690 V A	n_n rpm	η_n referred to P_{eff} %	$\cos\varphi_n$ -	M_{max} Nm	$M_{\text{max}}/M_{\text{eff}}$	I_{max} referred to M_{max} A	η_{max} %	$\cos\varphi_{\text{max}}$ -	I_0 A	$\cos\varphi_0$ -	J kgm ²	m kg
Synchronous speed 500 rpm – 12-pole version															
ARC 112 M8 TV					data on request									0.018	46
ARC 112 MX8 TV					data on request									0.023	53
ARC 112 MZ8 TV					data on request									0.029	62
ARC 132 S8 TV					data on request									0.043	90
ARC 132 M8 TV					data on request									0.053	95
ARC 132 MX8 TV					data on request									0.066	110
ARC 160 S8 TV	3.0	39	4.5	735	82.0	0.68	110	2.8	12	81.0	0.78	3.7	0.10	0.113	120
ARC 160 M8 TV	3.6	47	5.6	736	82.0	0.66	117	2.5	12	81.5	0.80	4.1	0.11	0.145	145
ARC 160 L8 TV	4.0	52		735			140	2.7						0.166	155
ARC 180 S8 TV	5.5	71	8.7	740	83.0	0.64	210	3.0	21	79.0	0.82	6.5	0.11	0.228	190
ARC 180 M8 TV	6.5	84	9.5	735	83.0	0.69	240	2.8	22	80.0	0.85	6.5	0.09	0.268	215
ARC 180 L8 TV	7.5	97		740			316	3.2						0.324	340
ARC 200 M8 TV	8.0	103	11.0	740	86.0	0.70	325	3.1	29	83.0	0.84	7.5	0.09	0.443	315
ARC 200 L8 TV	9.0	116	12.0	740	88.0	0.70	390	2.9	33	84.0	0.85	8.5	0.08	0.514	330
ARC 225 M8 TV	13.0	167	22.5	743	86.3	0.78	480	2.9	60	88.8	0.80	17.0	0.08	0.825	390
ARC 225 MX8 TV	14.0	180					540	3.0						0.920	440
ARC 250 S8 TV	17.5	226	30.5	740	90.5	0.73	590	2.6	72	89.8	0.81	18.5	0.07	1.350	510
ARC 250 M8 TV	22.0	284	38.0	740	90.5	0.74	715	2.5	95	90.7	0.77	24.0	0.07	1.550	560
ARC 280 S8 TV	28.0	359	49.5	745	92.0	0.71	1040	2.9	152	91.8	0.79	30.0	0.06	2.63	780
ARC 280 M8 TV	35.0	449	61.0	745	93.0	0.71	1320	2.9	200	91.6	0.81	40.0	0.06	3.33	855
ARC 280 MX8 TV	37.0	474	65.5	746	92.0	0.71	1685	3.6	232	92.3	0.80	60.0	0.05	3.60	890
ARC 315 M8 TV	55.0	710	90.5	741	93.6	0.75	2100	3.0	245	91.1	0.82	57.0	0.05	6.000	1050
ARC 315 L8 TV	68.0	875	117.0	745	94.4	0.71	2140	2.4	248	94.1	0.82	75.0	0.05	6.760	1250
ARC 315 LX8 TV	85.0	1090	141.0	745	93.0	0.75	2724	2.5	308	92.0	0.82	73.5	0.06	8.710	1460
ARC 355 M8 TV	90.0	1154	149.0	745	94.0	0.74	3461	3.0	416	93.5	0.80	79.0	0.05	9.500	1600
ARC 355 MX8 TV	110.0	1410	183.0	745	94.0	0.74	4230	3.0	504	94.0	0.80	96.0	0.05	13.400	2200
ARC 400 L8 TV	170.0	2176		746	data on request		6450							32.000	3120
ARC 400 LX8 TV	200.0	2560		746	data on request		7750							39.000	3460



Welded steel three-phase asynchronous motors

Transnorm motors
Series DS, DSf, DSo, DSWM
for mains and converter-fed operation

Welded steel three-phase asynchronous motors for rolling mills

Transnorm motors, series DS, DSf, DSo, DSWM for mains and converter-fed operation

The most important technical data are summarised in the following table.
Further information can be taken from the catalogue section "Technical explanations".

Product group	Roller table motors, squirrel-cage rotor, IEC
Series	DS..
Rated output	100 kW to 1500 kW
Sizes	355 to 630
Housing material	Sheet steel, with welded radial ribs or double jacket for type of cooling IC 31, IC 71
Rated torque	1000 Nm to 15000 Nm
Method of connection	Single-speed motors are designed in star-delta configuration as standard
Stator winding insulation	Thermal class 155, optional 155 [F(B)], 180 to EN 60034-1 (IEC 60034-1)
Type of protection	IP 55 acc. to DIN EN 60034-5 (IEC 60034-5), optionally IP 56 and higher
Type of cooling	IC 411 [self-ventilated], IC 416 [forced ventilation], IC 410 [non-ventilated] or IC 31 [water-jacket cooling] acc. to EN 60034-6 (IEC 60034-6)
Coolant temperature/ installation altitude	Standard -20 °C to +40 °C, Altitude 1000 m above sea level
Rated voltage	Rated voltage ranges A and B acc. to DIN EN 60034-1 (IEC 60034-1), Standard voltages to EN 60038 50 Hz, 230 V, 400 V, 500 V, and 690 V 60 Hz, 275 V, 480 V and 600 V
Types of construction	IM B3, IM B35, IM B5 and derived types complying with EN 60034-7
Paint finish	Normal finish "Moderate", colour RAL 7031, blue-grey Special finish "Worldwide", colour RAL 7031, blue-grey
Vibration severity grade	Grade "A" as standard for machines with no special vibration requirements
Shaft ends	acc. to DIN 748 (IEC 60072), balanced with half-key
Sound pressure level	acc. to DIN EN ISO 1680, tolerance +3 dB, see technical explanations for values
Limit speeds	Details upon request
Bearing design	Details upon request
Motor mass	See technical selection lists.
Terminal box	Details upon request
Documentation	An operating and maintenance manual, a terminal plan and a safety data sheet are supplied with each motor.
Tolerances	See section "Tolerances" in the chapter "Technical explanations"
Options	See "Overview of modifications" of the basic catalogue 01-2012 in the chapter "Technical explanations"

Welded steel three-phase asynchronous motors for rolling mills

Overview of sizes and outputs

Types of cooling IC 411 [self-ventilated], IC 416 [forced ventilation], IC 410 [non-ventilated] and IC 31 [water-jacket cooling]

Duty type S1, thermal class 155 [F], type of protection IP 55, rated voltage 690 V, rated frequency 50 Hz

Type of cooling	IC 411		IC 416		IC 410		IC 31	
Size	P _B [kW]	Type	P _B [kW]	Type	P _B [kW]	Type	P _B [kW]	Type
Synchronous speed 1500 rpm – 4-pole version								
355 M	340	DS 355 M...-4	340	DSf 355 M...-4	155	DSo 355 M...-4	340	DSWM 355 M...-4
355 L	400	DS 355 L...-4	400	DSf 355 L...-4	190	DSo 355 L...-4	400	DSWM 355 L...-4
400 M	490	DS 400 M...-4	490	DSf 400 M...-4	220	DSo 400 M...-4	490	DSWM 400 M...-4
400 L	550	DS 400 L...-4	550	DSf 400 L...-4	265	DSo 400 L...-4	550	DSWM 400 L...-4
450 S	610	DS 450 S...-4	610	DSf 450 S...-4	275	DSo 450 S...-4	610	DSWM 450 S...-4
450 M	770	DS 450 M...-4	770	DSf 450 M...-4	325	DSo 450 M...-4	770	DSWM 450 L...-4
450 L	840	DS 450 L...-4	840	DSf 450 L...-4	360	DSo 450 L...-4	840	DSWM 450 L...-4
500 M	960	DS 500 M...-4	960	DSf 500 M...-4	385	DSo 500 M...-4	960	DSWM 500 M...-4
500 L	1200	DS 500 L...-4	1200	DSf 500 L...-4	480	DSo 500 L...-4	1200	DSWM 500 L...-4
Synchronous speed 1000 rpm – 6-pole version								
355 M	280	DS 355 M...-6	280	DSf 355 M...-6	130	DSo 355 M...-6	280	DSWM 355 M...-6
355 L	330	DS 355 L...-6	330	DSf 355 L...-6	160	DSo 355 L...-6	330	DSWM 355 L...-6
400 M	410	DS 400 M...-6	410	DSf 400 M...-6	180	DSo 400 M...-6	410	DSWM 400 M...-6
400 L	460	DS 400 L...-6	460	DSf 400 L...-6	220	DSo 400 L...-6	460	DSWM 400 L...-6
450 S	510	DS 450 S...-6	510	DSf 450 S...-6	230	DSo 450 S...-6	510	DSWM 450 S...-6
450 M	640	DS 450 M...-6	640	DSf 450 M...-6	270	DSo 450 M...-6	640	DSWM 450 L...-6
450 L	700	DS 450 L...-6	700	DSf 450 L...-6	300	DSo 450 L...-6	700	DSWM 450 L...-6
500 M	800	DS 500 M...-6	800	DSf 500 M...-6	320	DSo 500 M...-6	800	DSWM 500 M...-6
500 L	1000	DS 500 L...-6	1000	DSf 500 L...-6	400	DSo 500 L...-6	1000	DSWM 500 L...-6
560 L	1120	DS 560 L...-6	1120	DSf 560 L...-6			1350	DSWM 560 L...-6
630 L							1500	DSWM 630 L...-6
Synchronous speed 750 rpm – 8-pole version								
355 M	210	DS 355 M...-8	210	DSf 355 M...-8	100	DSo 355 M...-8	210	DSWM 355 M...-8
355 L	250	DS 355 L...-8	250	DSf 355 L...-8	120	DSo 355 L...-8	250	DSWM 355 L...-8
400 M	310	DS 400 M...-8	310	DSf 400 M...-8	135	DSo 400 M...-8	310	DSWM 400 M...-8
400 L	350	DS 400 L...-8	350	DSf 400 L...-8	165	DSo 400 L...-8	350	DSWM 400 L...-8
450 S	380	DS 450 S...-8	380	DSf 450 S...-8	175	DSo 450 S...-8	380	DSWM 450 S...-8
450 M	480	DS 450 M...-8	480	DSf 450 M...-8	205	DSo 450 M...-8	480	DSWM 450 L...-8
450 L	530	DS 450 L...-8	530	DSf 450 L...-8	225	DSo 450 L...-8	530	DSWM 450 L...-8
500 M	600	DS 500 M...-8	600	DSf 500 M...-8	240	DSo 500 M...-8	600	DSWM 500 M...-8
500 L	750	DS 500 L...-8	750	DSf 500 L...-8	300	DSo 500 L...-8	750	DSWM 500 L...-8
560 L	840	DS 560 L...-8	840	DSf 560 L...-8			1010	DSWM 560 L...-8
630 L							1120	DSWM 630 L...-8



Light-duty roller table motors

Three-phase roller table motors with squirrel-cage rotor
Series IE2-AE1R
for mains and converter-fed operation

Light-duty roller table motors

**Three-phase roller table motors with squirrel-cage rotor
Series IE2-AE1R for mains and converter-fed operation**

The most important technical data are summarised in the following table.
Further information can be taken from the catalogue section "Technical explanations".

Product group	Squirrel-cage rotor, IEC/DIN
Rated output	0.09 kW to 500 kW IE2 version for output range 0.75 kW to 375 kW, 2, 4 and 6 poles
Sizes	56 to 355
Housing material	Grey cast iron
Rated torque	0.3 Nm to 3600 Nm
Efficiency determination	EN 60034-2-1, ≤ 1 kW direct measurement, > 1 kW residual loss method
Method of connection	Single-speed motors are designed in star-delta configuration as standard.
Stator winding insulation	Thermal class 155, optional 155 [F(B)], 180 to EN 60034-1 (IEC 60034-1)
Type of protection	IP 55 acc. to EN 60034-5 (IEC 60034-5)
Type of cooling	IC 411 acc. to EN 60034-6 (IEC 60034-6)
Coolant temperature/ installation altitude	Standard -20 °C to +40 °C, Altitude 1000 m above sea level
Rated voltage	Standard voltages acc. to EN 60038 50 Hz, 400 V 60 Hz, 460 V
Types of construction	IM B3, IM B35, IM B5 and derived types complying with DIN EN 60034-7
Paint finish	Normal finish "Moderate", colour RAL 7031, blue-grey Special finish "Worldwide", colour RAL 7031, blue-grey
Vibration severity grade	Grade "A" as standard for machines with no special vibration requirements
Shaft ends	acc. to DIN 748 (IEC 60072), balanced with half-key
Limit speeds	See tables of limit speeds
Bearing design	See tables of bearing design data
Motor mass	See technical selection lists
Terminal box	See section "Terminal boxes" in the chapter "Technical explanations" of the basic catalogue for low-voltage asynchronous motors/IEC squirrel-cage motors
Documentation	An operating and maintenance manual, a terminal plan and a safety data sheet are supplied with each motor.
Tolerances	See section "Tolerances" in the chapter "Technical explanations"
Options	See "Overview of modifications" in the basic catalogue for low-voltage asynchronous motors/IEC squirrel-cage motors

Three-phase roller table motors with squirrel-cage rotor Efficiency class “High Efficiency” acc. to EN 60034-30

with surface cooling, duty type S1, continuous duty, thermal class 155, type of protection IP 55
Efficiency determined to EN 60034-2-1:2007: ≤ 1 kW direct measurement, > 1 kW residual loss method

Motor selection data												Design point 400 V, 50 Hz/460 V, 60 Hz						
Type	U _B V	f _B Hz	P _B kW	M _B Nm	n _B rpm	1.00	η 0.75	0.50	cosφ _B -	I _B A	I _A /I _B -	M _A /M _B -	M _S /M _B -	M _K /M _B -	J kgm ²	m kg		
Synchronous speed 3000 rpm – 2-pole version																		
AE1R 56 K2	400	50	0.090	0.30	2825	- 65.8	64.6	64.3	0.83	0.22	5.0	2.0	2.0	2.4	0.00015	4.8		
	460	60	0.105	0.29	3410	- 72.0	71.0	70.0	0.83	0.22	5.3	2.5	2.5	2.8				
AE1R 56 G2	400	50	0.12	0.41	2810	- 67.3	65.8	61.9	0.83	0.31	4.7	2.0	2.0	2.2	0.00015	4.8		
	460	60	0.14	0.39	3410	- 71.4	70.2	66.5	0.82	0.30	5.2	2.0	2.0	2.3				
AE1R 63 K2	400	50	0.18	0.61	2840	- 75.0	73.8	64.4	0.82	0.42	5.7	2.4	2.3	2.7	0.00025	6.3		
	460	60	0.21					on request										
AE1R 63 G2	400	50	0.25	0.83	2860	- 73.7	73.9	70.1	0.84	0.55	6.2	2.6	2.5	2.8	0.00032	7.0		
	460	60	0.30					on request										
AE1R 71 K2	400	50	0.37	1.24	2860	- 76.3	74.2	72.7	0.87	0.78	7.1	2.9	2.7	3.1	0.00057	10.0		
	460	60	0.44	1.21	3460	- 82.3	83.9	82.4	0.86	0.78	7.3	3.0	2.8	3.2				
AE1R 71 G2	400	50	0.55	1.83	2870	- 78.7	78.3	75.4	0.86	1.14	7.4	3.0	2.7	3.3	0.00072	11.2		
	460	60	0.65	1.79	3465	- 83.0	82.4	76.6	0.87	1.13	7.8	2.8	2.5	2.9				
IE2-AE1R 80 K2	400	50	0.75	2.49	2880	IE2- 80.4	80.9	79.0	0.88	1.48	7.7	2.2	2.1	2.7	0.00132	15		
	460	60	0.9	2.48	3470	IE2- 75.5	80.2	77.9	0.89	1.54	7.3	2.1	1.8	2.4				
IE2-AE1R 80 G2	400	50	1.1	3.64	2885	IE2- 82.3	81.4	80.6	0.89	2.15	7.8	2.5	2.3	2.8	0.00170	18		
	460	60	1.3	3.58	3470	IE2- 84.0	83.8	80.6	0.89	2.16	8.0	2.4	2.2	2.7				
IE2-AE1R 90 S2	400	50	1.5	4.92	2910	IE2- 83.9	83.6	81.0	0.87	2.90	9.0	2.8	2.4	3.4	0.00275	23.5		
	460	60	1.8	4.90	3510	IE2- 84.0	87.0	84.6	0.88	2.90	8.1	2.1	2.0	3.1				
IE2-AE1R 90 L2	400	50	2.2	7.29	2880	IE2- 84.9	85.7	83.9	0.88	4.25	8.0	2.5	2.3	2.9	0.00275	23.5		
	460	60	2.6	7.16	3470	IE2- 85.5	86.5	87.4	0.88	4.30	7.2	2.1	1.8	2.7				
IE2-AE1R 100 L2	400	50	3	9.78	2930	IE2- 86.9	86.1	83.4	0.76	6.55	8.5	2.6	2.4	3.8	0.00450	31		
	460	60	3.6	9.75	3525	IE2- 87.5	86.5	85.2	0.80	6.45	7.5	1.8	1.6	3.2				
IE2-AE1R 112 MX2	400	50	4	13.08	2920	IE2- 87.0	86.4	85.8	0.84	7.90	8.3	2.3	2.1	3.3	0.00550	38		
	460	60	4.8	13.06	3510	IE2- 88.5	88.8	88.1	0.86	7.90	7.1	1.6	1.4	2.6				
IE2-AE1R 112 MV2	400	50	5.5	18.11	2900	IE2- 87.6	88.7	88.8	0.88	10.3	7.8	2.0	1.9	2.7	0.00680	46		
	460	60	6.6	18.1	3490	IE2- 89.5	89.9	89.4	0.88	10.5	8.0	1.9	1.8	2.6				
IE2-AE1R 132 S2 T	400	50	5.5	18.1	2900	IE2- 87.6	88.7	88.8	0.88	10.3	7.8	2.0	1.9	2.7	0.00680	48		
	460	60	6.6	18.1	3490	IE2- 89.5	89.9	89.4	0.88	10.5	8.0	1.9	1.8	2.6				
IE2-AE1R 132 S2	400	50	5.5	18.0	2915	IE2- 88.7	88.7	87.8	0.85	10.5	6.8	1.9	1.5	3.0	0.0110	57		
	460	60	6.6	18	3505	IE2- 89.5	88.8	87.2	0.86	11.0	6.4	1.9	1.5	3.0				
IE2-AE1R 132 SX2	400	50	7.5	24.5	2925	IE2- 88.8	89.2	88.3	0.91	13.5	6.7	2.1	1.6	2.9	0.0168	75		
	460	60	9.0	24.5	3505	IE2- 89.5	89.4	88.5	0.90	14.0	6.2	2.1	1.7	2.8				
IE2-AE1R 160 M2	400	50	11.0	35.6	2950	IE2- 90.3	90.3	89.1	0.90	19.5	7.7	2.3	1.7	3.1	0.0258	125		
	460	60	13.0	35.0	3550	IE2- 91.0	90.9	89.5	0.91	20.0	7.3	2.0	1.6	2.7				
IE2-AE1R 160 MX2	400	50	15.0	48.7	2940	IE2- 90.7	90.5	89.1	0.92	26.0	6.7	1.8	1.4	2.6	0.0675	140		
	460	60	16.5	44.6	3535	IE2- 90.2	89.7	88.4	0.91	25.0	6.5	1.9	1.4	2.6				
IE2-AE1R 160 L2	400	50	18.5	60.2	2935	IE2- 91.0	91.4	91.4	0.91	32.0	7.2	2.0	1.5	2.8	0.0675	140		
	460	60	22.0	59.6	3525	IE2- 91.6	91.3	89.6	0.92	37.5	7.0	1.8	1.3	2.6				
IE2-AE1R 180 M2	400	50	22	72	2935	IE2- 91.3	90.6	86.4	0.90	38.5	6.2	1.4	1.1	2.4	0.105	173		
	460	60	26	70	3545	IE2- 91.7	91.6	90.9	0.90	39.5	6.0	1.5	1.2	2.4				
IE2-AE1R 200 L2	400	50	30	97	2945	IE2- 92.0	91.3	90.5	0.91	52.0	6.9	1.7	1.3	2.6	0.128	210		
	460	60	36	97	3550	IE2- 92.4	92.5	91.6	0.91	54.0	6.0	1.4	1.1	2.3				
IE2-AE2R 200 LX2	400	50	37	120	2940	IE2- 92.5	92.3	91.6	0.92	63.0	7.4	1.9	1.4	2.9	0.154	233		
	460	60	44	119	3545	IE2- 93.0	92.4	92.1	0.91	65.5	6.8	1.9	1.5	2.8				
IE2-AE1R 225 M2	400	50	45	146	2950	IE2- 92.9	92.2	91.2	0.87	80.5	6.9	1.7	1.1	2.7	0.220	295		
	460	60	54	145	3545	IE2- 93.0	92.5	91.8	0.88	83.0	6.9	1.7	1.4	2.8				
IE2-AE1R 250 M2	400	50	55	178	2955	IE2- 93.5	93.7	93.2	0.89	95.5	8.2	2.3	1.9	2.8	0.375	385		
	460	60	66	178	3550	IE2- 93.6	93.7	93.0	0.90	98.5	7.6	2.1	1.8	2.7				
IE2-AE1R 280 S2	400	50	75	241	2970	IE2- 94.1	94.0	91.5	0.90	128	7.9	2.1	1.7	3.0	0.65	500		
	460	60	90	241	3570	IE2- 94.5	93.9	92.8	0.91	131	7.3	1.9	1.6	2.8				
IE2-AE1R 280 M2	400	50	90	289	2970	IE2- 94.4	94.1	91.9	0.91	151	7.7	2.0	1.7	2.8	0.68	550		
	460	60	110	294	3568	IE2- 94.5	94.0	93.7	0.91	161	7.5	1.9	1.6	2.7				
IE2-AE1R 315 S2	400	50	110	353	2975	IE2- 94.5	94.3	93.3	0.89	189	8.0	1.3	1.2	2.4	1.21	730		
	460	60	120	320	3580	IE2- 94.5	94.0	93.0	0.89	179	8.5	1.4	1.3	2.5				
IE2-AE1R 315 M2	400	50	132	424	2975	IE2- 95.0	94.8	94.5	0.89	225	9.2	1.4	1.2	2.4	1.44	820		
	460	60	145	387	3580	IE2- 95.0	94.5	94.0	0.90	213	9.4	1.4	1.2	2.4				
IE2-AE1R 315 MX2	400	50	160	514	2973	IE2- 94.8	94.8	94.8	0.89	274	8.2	1.3	1.3	2.4	1.76	955		
	460	60	175	467	3575	IE2- 95.4	95.0	94.0	0.90	256	8.2	1.7	1.6	2.7				
IE2-AE1R 315 MY2	400	50	200	640	2983	IE2- 95.4	95.0	94.3	0.88	344	9.4	2.8	2.0	3.0	2.82	1200		
	460	60	220	586	3585	IE2- 95.4	95.0	94.0	0.89	325	9.5	2.8	2.0	3.0				
IE2-AE1R 315 L2	400	50	250	800	2984	IE2- 95.4	95.4	95.4	0.92	411	9.0	2.3	1.2	2.3	3.66	1450		
	460	60	280	747	3580	IE2- 95.5	95.5	95.5	0.92	400	8.0	2.3	1.4	2.3				
IE2-AE1R 315 LX2	400	50	315	1008	2985	IE2- 95.4	95.4	95.0	0.92	518	8.5	2.8	1.6	2.5	4.43	1700		
	460	60	330	879	3585	IE2- 95.4	95.4	95.4	0.92	472	9.0	2.8	1.6	2.5				
IE2-AE2R 355 M2	400	50	355	1136	2985	IE2- 95.5	95.5	95.5	0.92	583	7.7	1.9	1.5	3.8	4.20	2000		
	460	60	375	999	3585	IE2- 95.4	95.0	94.5	0.91	542	8.5	1.5	1.3	2.2				
AE2R 355 MX2	400	50	400	1278	2990	- 95.5	95.5	95.5	0.91	664	9.4	1.8	1.0	3.0	4.50	2200		
	460	60	440	1170	3590	- 95.8	95.5	95.0	0.91	633	9.4	1.7	1.1	3.0				
AE2R 355 LY2	400	50	450	1440	2985	- 95.5	95.5	95.5	0.92	739	7.0	1.3	0.9	2.4	7.10	2400		
	460	60	490	1303	3590	- 95.5	95.5	95.0	0.92	700	7.5	1.5	0.9	2.4				
AE2R 355 L2	400	50	500	1597	2990	- 95.5	95.5	95.5	0.92	821	8.5							

Three-phase roller table motors with squirrel-cage rotor Efficiency class “High Efficiency” acc. to EN 60034-30

with surface cooling, duty type S1, continuous duty, thermal class 155, type of protection IP 55
Efficiency determined to EN 60034-2-1:2007: ≤ 1 kW direct measurement, > 1 kW residual loss method

Motor selection data										Design point 400 V, 50 Hz/460 V, 60 Hz							
Type	U _B V	f _B Hz	P _B kW	M _B Nm	n _B rpm	1.00	η 0.75	0.50	cosφ _B	I _B A	I _A /I _B	M _A /M _B	M _S /M _B	M _K /M _B	J kgm ²	m kg	
Synchronous speed 1500 rpm – 4-pole version																	
AE1R 56 K4	400	50	0.060	0.41	1400	-	65.3	65.0	58.8	0.67	0.20	3.6	2.3	2.3	2.5	0.00024	4.8
460	60	0.075	0.43	1680	-	66.3	64.9	56.4	0.71	0.20	3.9	2.1	2.1	2.5			
AE1R 56 G4	400	50	0.090	0.63	1370	-	67.9	64.5	60.1	0.71	0.28	3.3	1.8	1.7	2.1	0.00024	4.8
460	60	0.105	0.60	1670	-	66.5	65.8	64.9	0.72	0.28	3.6	2.0	1.9	2.2			
AE1R 63 K4	400	50	0.12	0.82	1400	-	69.7	68.2	63.1	0.71	0.35	3.8	2.0	1.9	2.3	0.00040	6.3
460	60	0.14	0.79	1700	-	70.5	70.6	66.1	0.71	0.35	4.1	2.0	1.9	2.4			
AE1R 63 G4	400	50	0.18	1.21	1425	-	72.1	69.3	63.2	0.64	0.57	4.4	1.8	1.8	2.7	0.00050	7.1
460	60	0.21	1.16	1725	-	71.3	68.8	62.9	0.66	0.56	4.8	2.6	2.6	2.9			
AE1R 71 K4	400	50	0.25	1.67	1430	-	77.0	76.6	73.0	0.71	0.66	5.6	2.5	2.3	2.9	0.00087	9.9
460	60	0.30	1.66	1725	-	77.1	76.5	72.8	0.74	0.66	5.2	2.1	2.0	2.7			
AE1R 71 G4	400	50	0.37	2.47	1430	-	79.0	78.2	73.1	0.69	0.98	6.2	2.8	2.6	3.2	0.00107	11
460	60	0.44	2.44	1725	-	80.0	79.6	76.0	0.72	0.98	6.1	2.5	2.4	3.2			
AE1R 80 K4	400	50	0.55	3.67	1430	-	79.4	79.6	78.7	0.80	1.25	6.0	2.4	2.3	2.7	0.00207	14.5
460	60	0.65	3.60	1725	-	81.2	80.5	76.9	0.81	1.24	6.2	2.2	2.1	2.6			
IE2-AE1R 80 G4	400	50	0.75	5.01	1430	IE2- 81.0	81.4	79.6	0.81	1.65	7.0	2.9	2.8	3.2	0.00260	17	
460	60	0.9	4.98	1725	IE2- 82.5	84.4	82.2	82.2	0.82	1.65	6.9	2.6	2.4	2.9			
IE2-AE1R 90 S4	400	50	1.1	7.32	1435	IE2- 82.0	82.3	80.4	0.80	2.42	6.8	2.4	2.2	2.9	0.00400	23	
460	60	1.3	7.16	1735	IE2- 84.0	84.8	83.5	83.5	0.81	2.40	6.6	2.5	2.3	3.0			
IE2-AE1R 90 L4	400	50	1.5	9.91	1445	IE2- 83.9	83.2	80.7	0.77	3.35	7.2	3.2	3.0	3.5	0.00450	28	
460	60	1.8	9.91	1735	IE2- 84.0	84.2	82.4	82.4	0.79	3.40	7.0	2.7	2.5	3.1			
IE2-AE1R 100 L4	400	50	2.2	14.4	1455	IE2- 85.9	85.2	81.7	0.77	4.80	9.3	3.2	3.0	3.6	0.00900	36	
460	60	2.6	14.1	1755	IE2- 87.5	86.6	84.5	84.5	0.76	4.90	7.7	2.2	2.1	3.4			
IE2-AE1R 100 LX4	400	50	3.0	19.7	1455	IE2- 86.5	86.3	84.5	0.77	6.50	9.0	3.3	3.1	3.9	0.01100	45	
460	60	3.6	19.6	1750	IE2- 87.5	87.8	86.0	86.0	0.79	6.50	7.7	2.6	2.5	3.2			
IE2-AE1R 112 MZ4	400	50	4.0	26.4	1445	IE2- 87.0	87.0	85.1	0.80	8.30	8.2	2.8	2.6	3.6	0.0130	50	
460	60	4.5	24.6	1745	IE2- 87.5	87.5	85.9	85.9	0.80	8.05	7.8	2.4	2.3	3.5			
IE2-AE1R 112 M4	400	50	4.0	26.2	1460	IE2- 87.6	88.0	86.9	0.86	7.6	8.3	2.6	2.3	3.9	0.0170	56	
460	60	4.8	26	1760	IE2- 89.5	88.9	87.5	87.5	0.87	7.7	7.8	2.4	2.1	3.6			
IE2-AE2R 132 S4	400	50	5.50	36.2	1450	IE2- 88.4	89.3	89.0	0.87	10.5	7.7	2.3	1.8	3.5	0.020	64	
460	60	6.60	36.1	1745	IE2- 89.5	90.1	89.7	89.7	0.88	10.5	7.1	2.0	1.6	3.2			
IE2-AE1R 132 M4	400	50	7.5	48.7	1470	IE2- 89.9	90.0	88.5	0.82	14.5	8.5	2.6	2.1	4.0	0.035	88	
460	60	9.0	48.6	1770	IE2- 90.8	90.6	89.0	89.0	0.83	15.0	8.1	2.5	2.0	3.8			
IE2-AE2R 160 M4	400	50	11.0	71	1470	IE2- 90.3	90.3	88.9	0.78	22.5	7.8	2.4	2.1	3.9	0.043	105	
460	60	13.0	70	1765	IE2- 91.3	91.5	90.4	90.4	0.80	22.5	7.5	2.3	1.9	3.6			
IE2-AE2R 160 L4	400	50	15.0	97	1480	IE2- 92.0	92.0	90.6	0.84	28	9.1	3.0	2.5	3.9	0.115	161	
460	60	18.0	97	1775	IE2- 92.5	92.4	91.4	91.4	0.85	28.5	8.5	2.7	2.3	3.5			
IE2-AE2R 180 M4	400	50	18.5	120	1470	IE2- 91.2	90.6	89.3	0.78	37.5	6.4	2.0	1.6	2.8	0.138	176	
460	60	22.0	118	1775	IE2- 92.4	91.5	90.1	90.1	0.80	37.50	6.1	1.9	1.5	2.6			
IE2-AE1R 180 L4	400	50	22	142	1475	IE2- 91.6	91.4	89.9	0.83	42.0	7.3	2.1	1.7	3.0	0.168	215	
460	60	26	139	1780	IE2- 93.0	91.7	90.0	90.0	0.84	42.0	7.2	2.0	1.7	2.9			
IE2-AE1R 200 L4	400	50	30	194	1480	IE2- 92.3	91.3	88.2	0.80	58.5	7.3	2.1	1.7	2.9	0.275	277	
460	60	36	193	1780	IE2- 93.0	92.5	91.4	91.4	0.82	59.5	6.8	2.0	1.7	2.8			
IE2-AE1R 225 S4	400	50	37	240	1475	IE2- 92.7	91.8	90.7	0.84	68.5	7.4	2.2	1.7	2.7	0.313	313	
460	60	44	237	1775	IE2- 93.6	92.9	92.1	92.1	0.83	71.5	6.5	1.9	1.6	2.5			
IE2-AE2R 225 M4	400	50	45	291	1475	IE2- 93.1	92.9	92.1	0.80	87.0	7.6	2.6	1.9	3.1	0.356	346	
460	60	45	242	1775	IE2- 93.6	92.7	91.2	91.2	0.80	75.5	8.3	2.9	2.1	3.3			
IE2-AE2R 250 M4	400	50	55	356	1477	IE2- 93.9	93.8	93.7	0.82	103	7.5	2.4	1.9	2.4	0.619	435	
460	60	63	339	1777	IE2- 94.1	93.6	93.2	93.2	0.83	101	7.2	2.3	1.8	2.3			
IE2-AE1R 280 S4	400	50	75	482	1485	IE2- 94.2	94.4	92.1	0.84	137	7.2	1.8	1.6	2.1	0.95	550	
460	60	90	483	1779	IE2- 94.5	94.2	93.9	93.9	0.84	142	6.6	1.7	1.4	2.0			
IE2-AE1R 280 M4	400	50	90	580	1483	IE2- 94.3	94.5	94.0	0.84	164	7.6	1.8	1.6	2.3	1.10	610	
460	60	105	563	1780	IE2- 95.0	94.6	94.1	94.1	0.84	166	7.4	1.8	1.6	2.2			
IE2-AE1R 315 S4	400	50	110	707	1485	IE2- 94.8	94.8	94.0	0.82	204	8.5	1.8	1.5	2.7	1.96	760	
460	60	132	707	1784	IE2- 95.2	95.2	94.6	94.6	0.85	205	8.0	1.6	1.5	2.2			
IE2-AE1R 315 M4	400	50	132	849	1484	IE2- 95.0	95.0	94.5	0.83	242	8.2	1.8	1.6	2.3	2.27	850	
460	60	145	776	1784	IE2- 95.0	95.0	94.5	94.5	0.85	225	8.2	1.9	1.7	2.3			
IE2-AE1R 315 MX4	400	50	160	1031	1482	IE2- 95.0	95.0	94.5	0.84	289	7.4	1.6	1.4	2.2	2.73	975	
460	60	175	939	1780	IE2- 95.1	95.1	94.5	94.5	0.85	272	8.0	1.6	1.5	2.2			
IE2-AE1R 315 MY4	400	50	200	1282	1490	IE2- 95.1	95.1	94.5	0.87	349	8.5	1.8	1.6	2.5	4.82	1270	
460	60	220	1174	1790	IE2- 95.4	95.4	95.0	95.0	0.87	333	8.8	2.0	1.6	2.6			
IE2-AE1R 315 L4	400	50	250	1602	1490	IE2- 95.4	95.4	95.3	0.88	430	9.0	2.2	1.5	2.7	5.93	1450	
460	60	280	1792	1790	IE2- 95.4	95.4	95.3	95.3	0.88	419	8.5	2.2	1.6	2.5			
IE2-AE1R 315 LX4	400	50	315	2019	1490	IE2- 95.4	95.4	95.0	0.88	542	9.0	2.4	1.6	2.6	6.82	1630	
460	60	330	1761	1790	IE2- 95.4	94.5	93.5	93.5	0.87	499	9.2	2.5	1.7	1.7			
IE2-AE2R 355 M4	400	50	355	2271	1493	IE2- 95.5	95.5	95.0	0.87	617	8.0	1.3	1.0	2.7	7.9	2150	
460	60	375	1997	1793	IE2- 95.4	95.4	94.5	94.5	0.87	567	9.0	1.3	0.9	2.9			
AE2R 355 MX4	400	50	400	2557	1494	-	95.5	95.5	0.88	687	8.5	1.3	1.0	3.0	9.5	2400	
460	60	425	2267	1790	-	95.8	95.8	95.5	0.87	640	9.0	1.4	1.0	3.1			
AE2R 355 LY4	400	50	450	2873	1496	-	95.5	95.5	0.86	791	8.5	1.4	0.8	2.9	10.0	2500	
460	60	475	2529	1794	-	95.8	95.8	95.5	0.83	750	9.2	1.5	1.0	3.5			
AE2R 355 L4	400	50	500	3198	1493	-	95.5	95.5	0.84	900	8.0	1.2	0.9	3.0	10.0	2500	
460	60	525	2795	1794	-	95.8	95.8	95.5	0.83	829	9.0	1.3	1.0	3.3			

Three-phase roller table motors with squirrel-cage rotor Efficiency class "High Efficiency" acc. to EN 60034-30

with surface cooling, duty type S1, continuous duty, thermal class 155, type of protection IP 55
Efficiency determined to EN 60034-2-1:2007: ≤ 1 kW direct measurement, > 1 kW residual loss method

Motor selection data										Design point 400 V, 50 Hz/460 V, 60 Hz							
Type	U _B V	f _B Hz	P _B kW	M _B Nm	n _B rpm	1.00	η 0.75	0.50	cosφ _B	I _B A	I _A /I _B	M _A /M _B	M _S /M _B	M _K /M _B	J kgm ²	m kg	
Synchronous speed 1000 rpm – 6-pole version																	
AE1R 71 K 6	400 460	50 60	0.18	1.84 on request	930	-	68.0	68.2	63.1	0.71	0.54	4.2	2.4	1.8	2.6	0.00130	11
AE1R 71 G 6	400 460	50 60	0.25	2.54 on request	935	-	71.5	71.4	66.9	0.67	0.75	4.6	2.8	1.9	3.0	0.00175	12.5
AE1R 80 K 6	400 460	50 60	0.37	3.74 on request	945	-	76.0	74.3	69.9	0.69	1.01	4.7	2.2	1.7	2.6	0.00325	15
AE1R 80 G 6	400 460	50 60	0.55	5.56 on request	945	-	76.0	76.5	73.4	0.70	1.49	4.2	2.0	1.9	3.5	0.00425	18
IE2-AE1R 90 S 6	400 460	50 60	0.75 0.90	7.50 7.47	955 1150	IE2- 78.2	78.3	75.1	78.3	0.71	1.95	4.9	2.4	2.3	2.6	0.00625	24
IE2-AE1R 90 L6	400 460	50 60	1.1	11.0 on request	955	IE2- 81.3	82.0	79.3	82.0	0.71	2.75	5.4	2.5	2.4	2.8	0.00720	30
IE2-AE1R 100 LX6	400 460	50 60	1.5	15.0 on request	955	IE2- 82.6	83.5	81.5	83.5	0.76	3.45	5.9	2.3	2.2	2.8	0.01390	36
IE2-AE1R 112 MV6	400 460	50 60	2.2	22.0 on request	955	IE2- 82.2	82.5	79.8	82.5	0.75	5.15	5.7	2.4	2.3	2.9	0.01550	48
IE2-AE1R 112 MZ6	400 460	50 60	3.0	30.0	955	IE2- 83.3	83.6	81.3	83.6	0.75	6.85	6.5	2.8	2.7	3.5	0.01650	50
IE2-AE1R 132 S6	400 460	50 60	3.0 3.6	29.8 29.6	963 1160	IE2- 84.9	85.2	83.9	85.2	0.80	6.4	6.0	2.0	1.3	3.0	0.023	55
IE2-AE2R 132 M6	400 460	50 60	4.0 4.5	40 37.2	955 1155	IE2- 85.1	86.0	85.2	86.0	0.82	8.3	5.7	2.1	2.0	2.9	0.029	66
IE2-AE1R 132 MX6	400 460	50 60	5.5 6.6	54 54	970 1170	IE2- 86.1	85.5	82.4	86.1	0.77	12	5.7	2.2	1.7	2.7	0.053	85
IE2-AE2R 160 M6	400 460	50 60	7.5 9	74 73	970 1170	IE2- 87.5	87.6	85.9	87.5	0.79	15.5	5.9	2.1	1.8	2.9	0.053	103
IE2-AE2R 160L 6	400 460	50 60	11 13	108 106	975 1175	IE2- 88.9	88.8	87.0	88.9	0.81	22.0	6.8	2.7	2.4	3.1	0.166	155
IE2-AE2R 180 L6	400 460	50 60	15 15	148 122	970 1175	IE2- 89.7	88.8	87.8	89.7	0.83	29.0	5.6	2.3	1.7	2.6	0.166	157
IE2-AE1R 200 L6	400 460	50 60	18.5 22.0	180 179	980 1175	IE2- 90.4	88.8	86.5	90.4	0.85	35	6.6	2.3	1.7	2.9	0.268	208
IE2-AE2R 200 LX6	400 460	50 60	22.0 25	215 202	975 1180	IE2- 90.9	89.9	88.5	90.9	0.84	41.5	6.7	2.4	2.0	3.0	0.324	238
IE2-AE2R 225 M6	400 460	50 60	30 25	294 201	975 1185	IE2- 91.7	91.4	90.6	91.7	0.87	54.5	6.7	2.3	1.9	2.8	0.514	308
IE2-AE2R 250 M6	400 460	50 60	37 40	361 324	979 1179	IE2- 92.2	92.3	91.8	92.2	0.86	67.5	6.6	2.7	2.0	2.6	0.92	407
IE2-AE1R 280 S6	400 460	50 60	45 49	437 395	983 1185	IE2- 93.0	92.7	92.4	93.0	0.87	80.5	6.5	2.2	1.7	2.4	1.48	560
IE2-AE1R 280 M6	400 460	50 60	55 64	531 514	990 1190	IE2- 93.6	93.5	93.0	93.6	0.85	100	7.6	2.0	1.5	2.5	2.63	710
IE2-AE1R 315 S6	400 460	50 60	75 90	723 722	990 1190	IE2- 93.9	93.7	93.5	93.9	0.87	133	7.8	1.9	1.5	2.5	3.33	804
IE2-AE1R 315 M6	400 460	50 60	90 99	868 794	990 1190	IE2- 94.0	94.0	93.5	94.0	0.88	157	7.5	1.8	1.5	2.5	3.60	865
IE2-AE1R 315 MX6	400 460	50 60	110 110	1061 883	990 1190	IE2- 94.3	94.3	94.0	94.3	0.87	194	7.5	1.8	1.4	2.3	6.67	1210
IE2-AE1R 315 MY6	400 460	50 60	132 145	1273 1164	990 1190	IE2- 94.6	94.3	94.0	94.6	0.87	231	7.5	1.9	1.4	2.2	6.67	1250
IE2-AE1R 315 L6	400 460	50 60	160 175	1543 1404	990 1190	IE2- 94.8	94.5	93.5	94.8	0.88	277	7.5	2.0	1.5	2.4	8.6	1430
IE2-AE1R 315 LX6	400 460	50 60	200 220	1929 1766	990 1190	IE2- 95.0	95.0	94.5	95.0	0.86	353	7.0	1.9	1.5	2.2	8.6	1460
IE2-AE2R 355 M6	400 460	50 60	250 280	2402 2241	994 1193	IE2- 95.0	95.0	94.7	95.0	0.84	452	7.0	1.5	1.2	2.2	8.2	1850
IE2-AE2R 355 MX6	400 460	50 60	315 330	3023 2633	995 1197	IE2- 95.2	95.2	95.2	95.2	0.86	555	7.0	1.3	1.1	2.2	12.1	2200
IE2-AE2R 355 LY6	400 460	50 60	355 375	3407 2997	995 1195	IE2- 95.0	95.0	94.0	95.0	0.77	700	7.5	1.8	1.5	2.6	14.0	2400

Three-phase roller table motors with squirrel-cage rotor Efficiency class "High Efficiency" acc. to EN 60034-30

with surface cooling, duty type S1, continuous duty, thermal class 155, type of protection IP 55
Efficiency determined to EN 60034-2-1:2007: ≤ 1 kW direct measurement, > 1 kW residual loss method

Motor selection data													Design point 400 V, 50 Hz/460 V, 60 Hz				
Type	U _b V	f _b Hz	P _b kW	M _b Nm	n _b rpm	1.00	η 0.75	0.50	cosφ _b -	I _b A	I _k /I _b -	M _A /M _B -	M _S /M _B -	M _K /M _B -	J kgm ²	m kg	
Synchronous speed 750 rpm – 8-pole version																	
AE1R 80 K8	400 460	50 60	0.18 0.18	2.42	710	68.0	on request	on request	0.61 on request	0.63	3.5	1.9	1.9	2.6	0.00300	14.0	
AE1R 80 G8	400 460	50 60	0.25 0.25	3.39	705	70.0	on request	on request	0.63 on request	0.82	3.5	1.9	1.9	2.4	0.00375	17.0	
AE1R 90 S8	400 460	50 60	0.37 0.37	5.05	710	73.0	71.8	67.2	0.63 on request	1.16	3.1	1.7	1.6	1.8	0.00625	25.0	
AE1R 90 L8	400 460	50 60	0.55 0.55	7.40	700	72.0	71.6	67.6	0.64 on request	1.72	3.8	1.7	1.7	2.4	0.00720	30.0	
AE1R 100 L8	400 460	50 60	0.75 0.75	10.0	715	77.0	75.4	70.9	0.62 on request	2.27	4.6	2.6	2.5	3.0	0.01225	33.5	
AE1R 100 LX8	400 460	50 60	1.1 1.1	14.8	710	79.0	78.6	75.2	0.63 on request	3.20	4.3	2.0	1.9	2.6	0.014	36	
AE1R 112 MV8	400 460	50 60	1.5 1.5	20.5	700	78.0	78.5	75.8	0.65 on request	4.25	3.8	1.7	1.6	2.2	0.016	48	
AE1R 132 S8	400 460	50 60	2.2 2.6	29.2 28.5	720 870	81.7 83.6	81.0 82.7	77.5 78.3	0.65 0.67	6	4.8 5.1	2.2 2.0	2.0 1.8	3.2 3.1	0.018	55	
AE1R 132 M8	400 460	50 60	3.0 3.6	39.8 39.5	720 870	82.7 84.2	83.0 84.5	81.3 83.0	0.74 0.75	7.1 7.2	3.9 3.6	1.6 1.4	1.3 1.2	1.9 1.8	0.043	74	
AE1R 160 M8	400 460	50 60	4.0 4.0	53.2	718	84.2	83.7	81.9	0.72 on request	9.5	4.6	1.6	1.6	2.5	0.053	86	
AE2R 160 MX8	400 460	50 60	5.5 6.6	73.0 73.0	715 865	83.9 86.4	84.0 86.7	81.9 85.3	0.71 0.72	13.5 13.5	4.3 4.2	1.7 1.6	1.5 1.4	2.5 2.3	0.0530	103	
AE1R 160 L8	400 460	50 60	7.5 99	99	725	87.5	87.0	83.5	0.77 on request	16	5.5	2.0	2.0	2.8	0.145	136	
AE2R 180 L8	400 460	50 60	11 13	144.0	730	87.9	87.4	85.2	0.67 on request	25.5	4.3	1.9	1.6	2.3	0.1660	157	
AE1R 200 L8	400 460	50 60	15.0 18.0	197 196	727 878	88.2 88.9	88.1 88.7	86.4 87.4	0.77 0.78	32 32.50	4.9 4.8	1.9 1.8	1.7 1.6	2.3 2.2	0.268	200	
AE2R 225 S8	400 460	50 60	18.5 22	240 237	735 885	90.7 91.8	90.7 91.5	89.4 90.2	0.80 0.81	37.0 37.0	6.1 5.7	2.1 2.0	1.9 1.7	2.9 2.6	0.514	305	
AE2R 225 M8	400 460	50 60	22 26	286 281	735 883	90.3 91.3	90.3 91.1	88.7 89.6	0.77 0.79	45.5 45.0	6.1 5.9	2.2 2.1	2.0 1.8	2.9 2.7	0.514	307	
AE2R 250 M8	400 460	50 60	30 36	391 391	732 880	91.5 91.9	91.7 92.3	90.9 91.8	0.77 0.78	61.5 63.00	5.6 5.3	2.3 2.1	2.0 1.8	2.5 2.3	0.95	405	
AE1R 280 S8	400 460	50 60	37 45	479 484	737 888	92.2 91.7	92.1 91.2	90.9 89.0	0.79 0.79	73.5 78.00	6.0 6.0	2.3 2.1	1.9 1.6	2.5 2.2	1.55	550	
AE1R 280 M8	400 460	50 60	45 60	581	740	92.7	92.7	92.0	0.79 on request	88.5	6.7	1.8	1.5	2.5	2.63	690	
AE1R 315 S8	400 460	50 60	55 66	710 708	740 890	93.0 93.0	93.0 93.0	92.5 92.5	0.80 0.80	107 111	6.0 5.8	1.8 1.6	1.5 1.4	2.2 2.0	3.33	800	
AE1R 315 M8	400 460	50 60	75 60	968	740	93.5	93.5	93.0	0.81 on request	143	6.0	1.8	1.5	2.1	3.6	880	
AE1R 315 MX8	400 460	50 60	90 60	1161	740	92.1	91.6	90.1	0.81	174	6.0	1.9	1.5	2.2	6.0	1050	
AE1R 315 MY8	400 460	50 60	110 60	1420	740	93.8	93.3	91.2	0.81 on request	209	6.5	2.1	1.8	2.4	6.76	1250	
AE1R 315 L8	400 460	50 60	132 60	1704	740	94.4	94.0	93.5	0.83 on request	243	7.5	2.2	1.8	2.5	8.71	1430	
AE1R 315 LX8	400 460	50 60	160 190	2065 2039	740 890	94.2 94.3	94.2 94.3	93.8 94.0	0.80 0.81	306 312	7.2 7.0	2.2 2.1	1.8 1.7	2.5 2.3	8.71	1430	
AE2R 355 M8	400 460	50 60	200 60	2571	743	94.7	94.1	91.5	0.77 on request	396	7.0	1.2	1.0	2.6	9.5	1850	
AE2R 355 MX8	400 460	50 60	250 60	3205	745	95.8	95.8	95.5	0.83 on request	454	7.0	1.2	1.0	2.6	13.4	2200	
AE2R 355 LY8	400 460	50 60	280 60	3599	743	94.8	94.1	91.5	0.78 on request	547	7.0	1.2	1.0	2.6	15.8	2400	

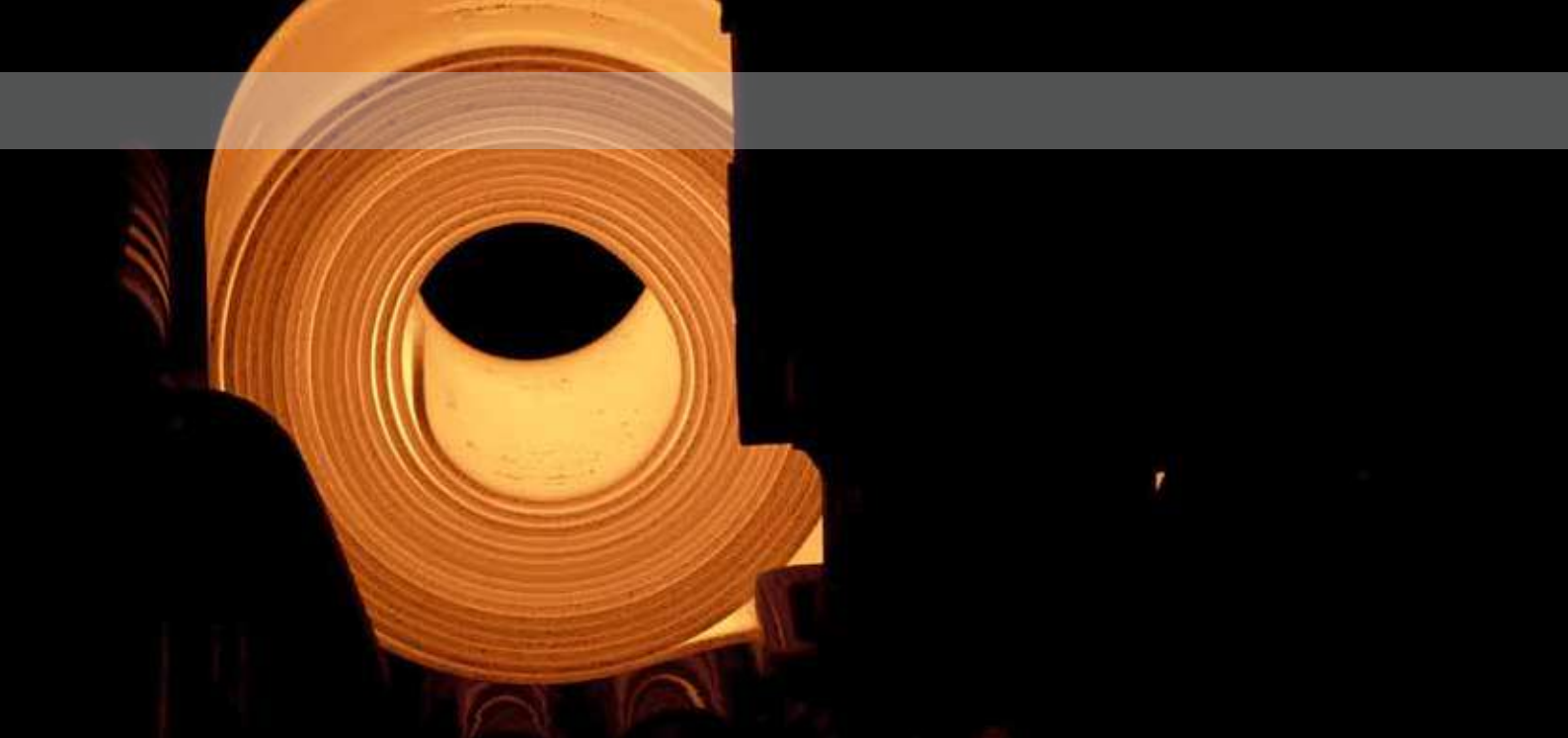

Dimensions

Flange dimensions
Heavy-duty roller table motors
Welded steel three-phase asynchronous motors
Light-duty roller table motors

Notes concerning dimensions

Dimension designations in accordance with EN 50347 and IEC 60072

Flange sizes in the dimension tables are specified in accordance with DIN 42948.

VEM motors GmbH reserves the right to modify technical data without prior notice. The dimensions shown in catalogues may not be up to date. Binding dimensional data can be requested from the VEM sales organisation.

All dimensions in mm

Flange dimensions

Flanges with threaded holes

Flange type to E DIN EN 50347	Flange type to DIN 42948	LA c_1	M e_1	N b_1	P a_1	S s_1	T f_1
FT 65	C 80	6.5	65	50	80	M5	2.5
FT 75	C 90	8	75	60	90	M5	2.5
FT 85	C 105	8.5	85	70	105	M6	2.5
FT 100	C 120	8	100	80	120	M6	3
FT 115	C 140	10	115	95	140	M8	3
FT 130	C 160	10	130	110	160	M8	3.5
FT 165	C 200	12	165	130	200	M10	3.5
FT 215	C 250	12	215	180	250	M12	4

Flanges with through-holes

Flange type to E DIN EN 50 347	Flange type to DIN 42948	LA c_1	M e_1	N b_1	P a_1	S s_1	T f_1
FF 100	A 120	9	100	80	120	7	3
FF 115	A 140	9	115	95	140	9	3
FF 130	A 160	9	130	110	160	9	3.5
FF 165	A 200	10	165	130	200	11	3.5
FF 215	A 250	11	215	180	250	14	4
FF 265	A 300	12	265	230	300	14	4
FF 300	A 350	13	300	250	350	18	5
FF 350	A 400	15	350	300	400	18	5
FF 400	A 450	16	400	350	450	18	5
FF 500	A 550	18	500	450	550	18	5
FF 600	A 660	22	600	550	660	22	6
FF 740	A 800	25	740	680	800	22	6
FF 940	A1000	25	940	880	1000	28	6
FF 1080	A1150	32	1080	1000	1150	28	6

According to DIN EN 50347, the different sizes of FF flanges possess through-holes, while FT flanges possess threaded holes. The flange designations A and C defined in DIN 42948 remain valid.

Flange assignments which deviate from the standard are specified in the flange assignment tables.

For tolerances for the dimension N (b_1), refer to the corresponding dimension tables LA (c_1) depth of engagement

Three-phase roller table motors with squirrel-cage rotor

Series ARB

with surface cooling, type of cooling IC 410, type of protection IP 55

Type of construction IM B3 [IM 1001]

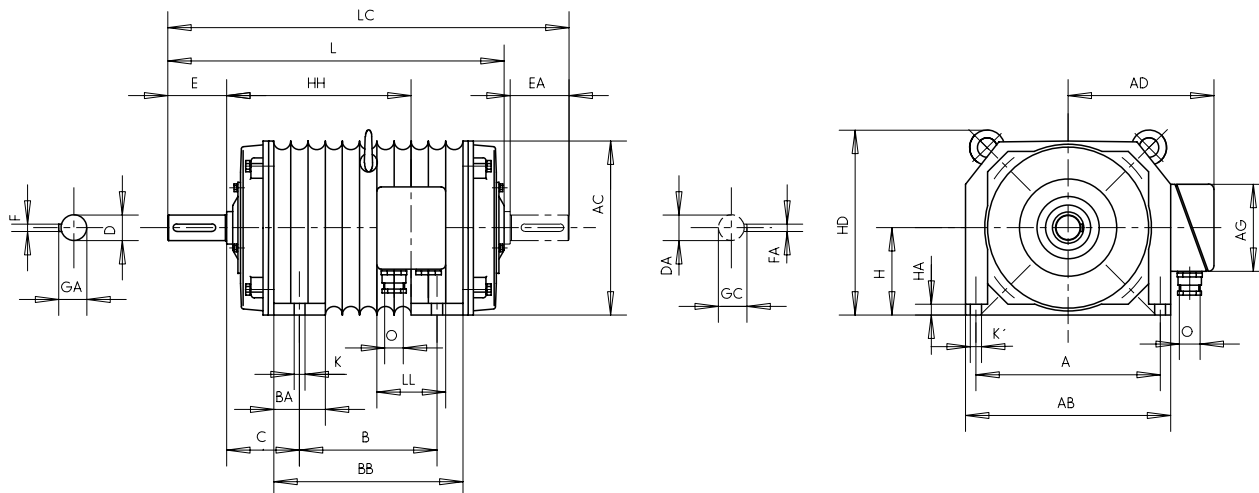

Type of construction IM B35 [IM 2001]

Flange dimensions, see page 56

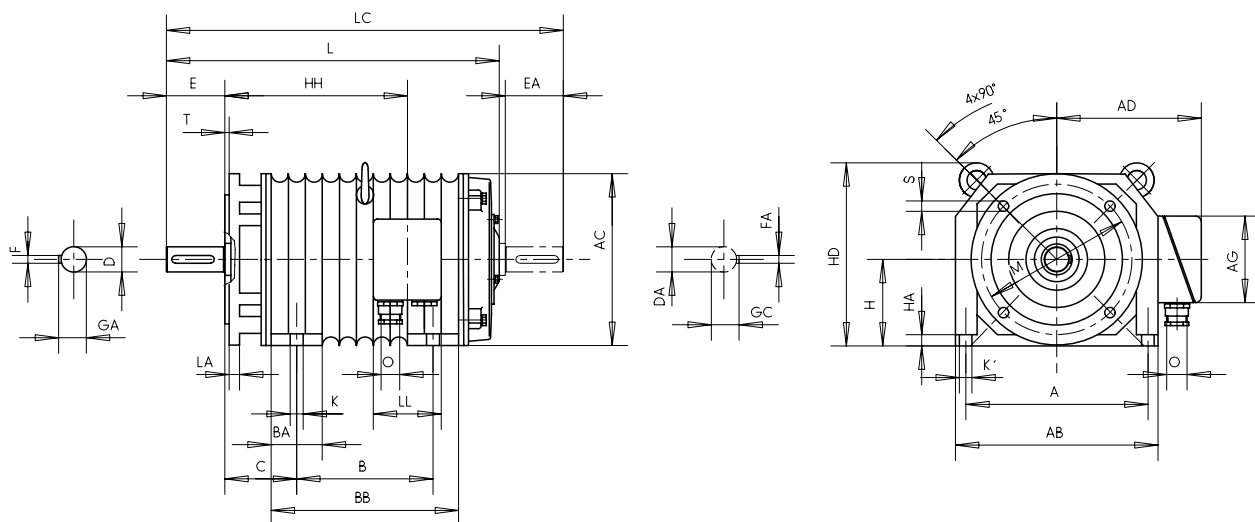

Type designation	-	A	AB	AC	AD	B	BA	BA1	BB	C	CA	D	DA	DB ¹⁾	E	EA	F	FA
	B5	b	f	g	g1	a	m	m1	e	w1	w2	d	d1	-	l	l1	u	u1
ARB 22	A195	216	268	194	180	178	64	-	242	130	130	24	24	M12	50	50	8	8
ARB 33	A250a	230	280	236	210	250	85	-	335	123	123	28	28	M12	60	60	8	8
ARB 54	A300a	320	390	330	245	270	90	-	360	164	164	38	38	M12	80	80	10	10
ARB 65	A350a	370	450	380	280	315	77	-	392	187.5	188	48	48	M16	110	110	14	14

¹⁾ Centre holes to DIN 332-DS

Type designation	GA	GC	H	HA	HD	K	K'	L	LC	HH	KK Type	AG	LL	0	Hole pattern
	t	t1	h	c	p	s	s'	k	k1	A					
ARB 22	27	27	132	20	245	13	13	487	538	294	ARB	130	130	M32 x 1.5	4L
ARB 33	31	31	125	25	266	15	15	552	616	347	ARB	130	130	M32 x 1.5	4L
ARB 54	41	41	170	32	361	22	22	660	758	421	ARB	130	130	M32 x 1.5	4L
ARB 65	52	52	200	32	400	22	22	770	910	485	ARB	130	130	M32 x 1.5	4L

Three-phase roller table motors with squirrel-cage rotor

Series ARB

with surface cooling, type of cooling IC 410, type of protection IP 55

Type of construction IM B5 [IM 3001] up to size 280

Type of construction IM V1 [IM 3011]

Flange dimensions, see page 56

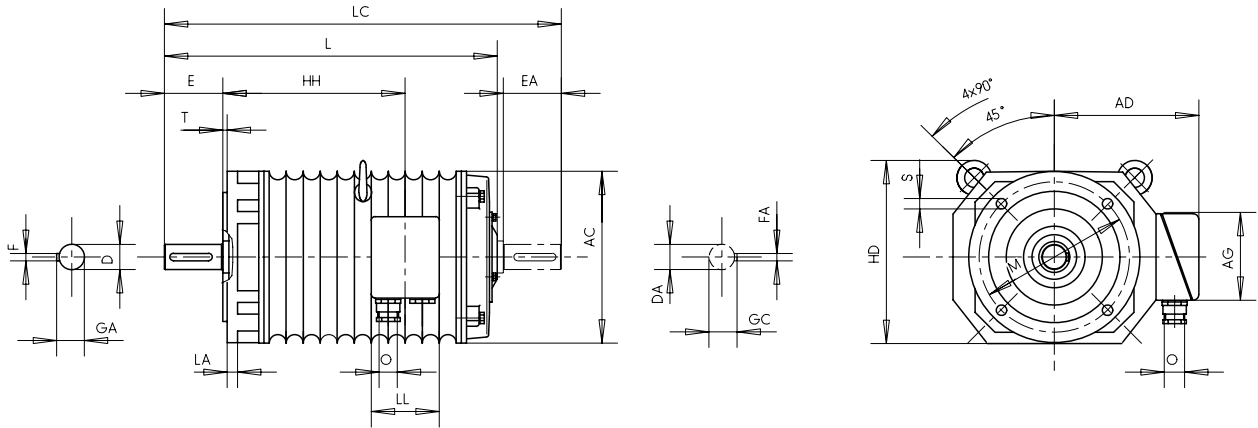

Type designation - B5	AC g	AD g1	D d	DA d1	DB') -	E l	EA l1	F u	FA u1	GA t	GC t1	H h	HA c	L k	LC k1	LD A	KK Type	AG	LL	O	Hole pattern	
ARB 22	A195	194	180	24	24	M12	50	50	8	8	27	27	132	20	487	538	294	ARB	130	130	M32 x 1.5	4L
ARB 33	A250a	236	210	28	28	M12	60	60	8	8	31	31	125	25	552	616	347	ARB	130	130	M32 x 1.5	4L
ARB 54	A300a	330	245	38	38	M12	80	80	10	10	41	41	170	32	660	758	421	ARB	130	130	M32 x 1.5	4L
ARB 65	A350a	380	280	48	48	M16	110	110	14	14	52	52	200	32	770	910	485	ARB	130	130	M32 x 1.5	4L

Three-phase roller table motors with squirrel-cage rotor

Series ARC

with surface cooling, type of cooling IC 410, type of protection IP 55

Type of construction IM B5 [IM 3001] up to size 250

Type of construction IM V1 [IM 3011]

Flange dimensions, see page 56

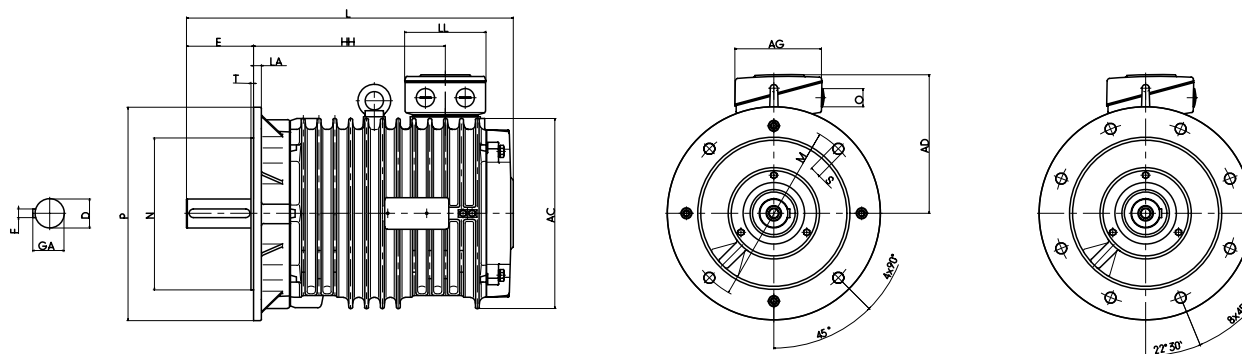

Type designation	-	AC	D	DA	DB ¹⁾	E	EA	F	FA	GA	GC	H	HA	L	LC	LD	KK Type	AG	LL	O	Hole pattern
	B5	g	d	d1	-	l	l1	u	u1	t	t1	h	h	c	k	k1	A				
ARC 112 M	A300	217	32	32	M12	80	80	10	10	35	35	112	18	450	540	-	KK 25A	143	134	M32 x 1.5	4L
ARC 132 S	A350	258	38	38	M12	80	80	10	10	41	41	132	20	515	605	-	KK 25A	143	134	M32 x 1.5	4L
ARC 132 M	A350	258	38	38	M12	80	80	10	10	41	41	132	20	515	605	-	KK 25A	143	134	M32 x 1.5	4L
ARC 160 S	A350	313	48	42	M16	110	110	14	12	51.5	45	160	25	540	658	-	KK 25A	143	134	M32 x 1.5	4L
ARC 160 M	A350	313	48	42	M16	110	110	14	12	51.5	45	160	25	540	658	-	KK 25A	143	134	M32 x 1.5	4L
ARC 160 MX	A350	313	48	42	M16	110	110	14	12	51.5	45	160	25	592	710	-	KK 25A	143	134	M32 x 1.5	4L
ARC 160 L	A350	313	48	42	M16	110	110	14	12	51.5	45	160	25	592	710	-	KK 25A	143	134	M32 x 1.5	4L
ARC 180 S	A400	351	55	48	M20	110	110	16	14	59	51.5	180	25	610	730	-	KK 63A	175	162	M40 x 1.5	4L
ARC 180 M	A400	351	55	48	M20	110	110	16	14	59	51.5	180	25	610	730	-	KK 63A	175	162	M40 x 1.5	4L
ARC 180 L	A400	351	55	48	M20	110	110	16	14	59	51.5	180	25	694	814	-	KK 63A	175	162	M40 x 1.5	4L
ARC 200 M	A450	390	60	55	M20	140	110	18	16	64	59	200	27	845	965	-	KK 100A	213	207	M50 x 1.5	8L
ARC 200 L	A450	390	60	55	M20	140	110	18	16	64	59	200	27	845	965	-	KK 100A	213	207	M50 x 1.5	8L
ARC 225 M	A550	440	65	55	M20	140	110	18	16	69	59	225	30	815	935	-	KK 100A	213	207	M50 x 1.5	8L
ARC 250 S	A550	490	75	65	M20	140	140	20	18	79.5	69	250	33	840	990	-	KK 200A	282	242	M63 x 1.5	8L
ARC 250 M	A550	490	75	65	M20	140	140	20	18	79.5	69	250	33	840	990	-	KK 200A	282	242	M63 x 1.5	8L
ARC 280 S	A660	550	80	70	M20	170	140	22	20	85	74.5	280	40	970	1120	-	KK 200A	282	242	M63 x 1.5	8L
ARC 280 M	A660	550	80	70	M20	170	140	22	20	85	74.5	280	40	970	1120	-	KK 200A	282	242	M63 x 1.5	8L
ARC 315 M	A660	616	90	75	M24	170	140	25	20	95	79.5	315	44	1275	1415	-	KK 200A	282	242	M63 x 1.5	8L
ARC 315 L	A660	616	90	75	M24	170	140	25	20	95	79.5	315	44	1275	1415	-	KK 200A	282	242	M63 x 1.5	8L
ARC 355 MY	A800	715	100	80	M24	210	170	28	22	106	85	355	50	1400	1580	-	KK 400A	311	294	M63 x 1.5	8L
ARC 355 M	A800	715	100	80	M24	210	170	28	22	106	85	355	50	1400	1580	-	KK 400A	311	294	M63 x 1.5	8L
ARC 355 MX	A800	715	100	80	M24	210	170	28	22	106	85	355	50	1400	1580	-	KK 400A	311	294	M63 x 1.5	8L
ARC 355 L	A800	715	100	80	M24	210	170	28	22	106	85	355	50	1400	1580	-	KK 400A	311	294	M63 x 1.5	8L
ARC 400 L	A1000	800	110	90	M24	210	170	28	25	116	95	400	55	1630	1820	-	KK 400B	415	340	M63 x 1.5	8L

Three-phase roller table motors with squirrel-cage rotor

Series ARC

with surface cooling, type of cooling IC 410, type of protection IP 55

Type of construction IM B3 [IM 1001]

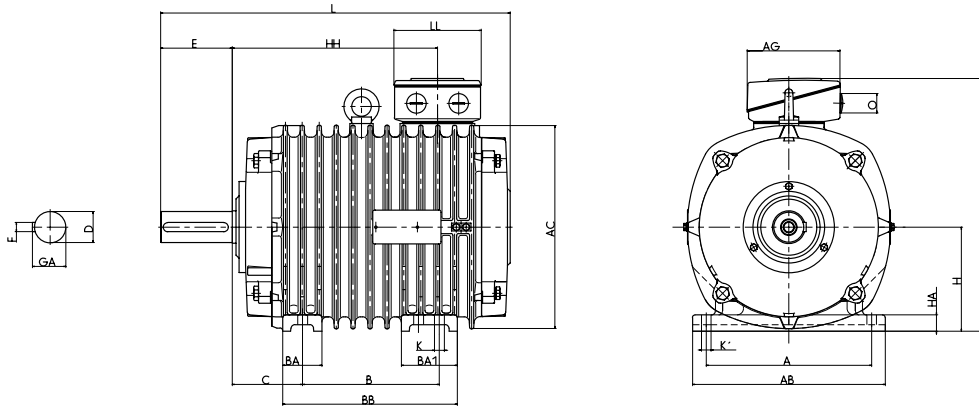

Type designation	-	A	AB	AC	B	BA	BA1	BB	C	CA	D	DA	DB ¹⁾	E	EA
	B5	b	f	g	a	m	m1	e	w1	w2	d	d1	-	l	l1
ARC 112 M	A300	190	226	217	140	55	55	190	70	170	32	32	M12	80	80
ARC 132 S	A350	216	256	258	140	60	87	232	89	216	38	38	M12	80	80
ARC 132 M	A350	216	256	258	178	60	87	232	89	178	38	38	M12	80	80
ARC 160 S	A350	254	296	313	178	60	87	268	108	152	48	42	M16	110	110
ARC 160 M	A350	254	296	313	210	60	87	268	108	120	48	42	M16	110	110
ARC 160 MX	A350	254	296	313	210	60	112	320	108	172	48	42	M16	110	110
ARC 160 L	A350	254	296	313	254	60	112	320	108	128	48	42	M16	110	110
ARC 180 S	A400	279	328	351	203	70	124	321	121	186	55	48	M20	110	110
ARC 180 M	A400	279	328	351	241	70	124	321	121	148	55	48	M20	110	110
ARC 180 L	A400	279	328	351	279	70	70	350	121	230	55	48	M20	110	110
ARC 200 M	A450	318	372	390	267	75	117	380	133	298	60	55	M20	140	110
ARC 200 L	A450	318	372	390	305	75	117	380	133	277	60	55	M20	140	110
ARC 225 M	A550	356	413	440	311	80	80	390	149	225	65	55	M20	140	110
ARC 250 S	A550	406	469	490	311	85	130	437	168	231	75	65	M20	140	140
ARC 250 M	A550	406	469	490	349	85	130	437	168	193	75	65	M20	140	140
ARC 280 S	A660	457	522	550	368	100	140	516	190	252	80	70	M20	170	140
ARC 280 M	A660	457	522	550	419	100	140	516	190	201	80	70	M20	170	140
ARC 315 M	A660	508	590	616	457	120	155	622	216	432	90	75	M24	170	140
ARC 315 L	A660	508	590	616	508	120	155	622	216	394	90	75	M24	170	140
ARC 355 MY	A800	610	700	715	560	125	163	733	254	386	100	80	M24	210	170
ARC 355 M	A800	610	700	715	560	125	163	733	254	386	100	80	M24	210	170
ARC 355 MX	A800	610	700	715	560	125	163	733	254	386	100	80	M24	210	170
ARC 355 L	A800	610	700	715	630	125	163	733	254	316	100	80	M24	210	170
ARC 400 L	A1000	686	810	800	710	212	293	1053	280	450	110	90	M24	210	170

¹⁾Centre holes to DIN 332-DS

Three-phase roller table motors with squirrel-cage rotor

Series ARC

with surface cooling, type of cooling IC 410, type of protection IP 55

Type of construction IM B35 [IM 2001]

Flange dimensions, see page 56

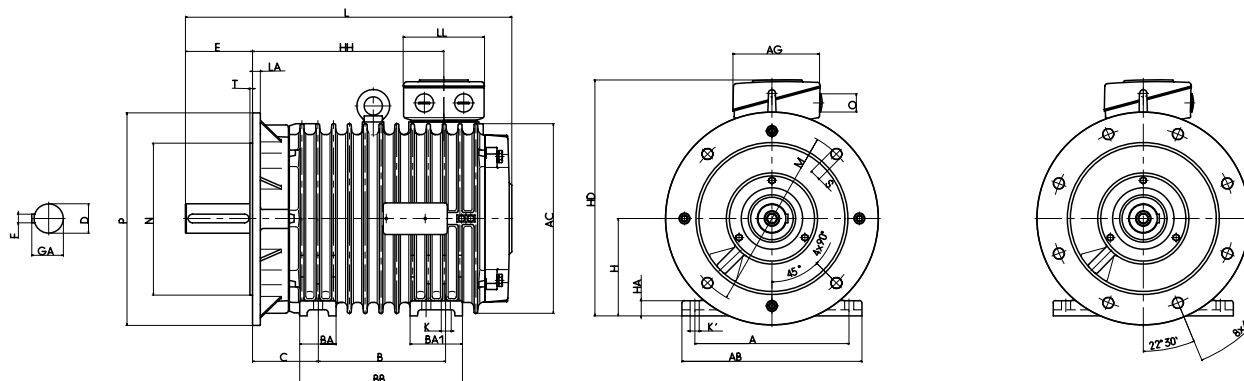

Type designation	F u	FA u1	GA t	GC t1	H h	HA c	HD p	K s	K' s'	L k	LC k1	KK Type	AG x	LL z	O	Hole pattern
ARC 112 M	10	10	35	35	112	18	292	12	12	450	540	KK 25A	143	134	M32 x 1.5	4L
ARC 132 S	10	10	41	41	132	20	332	12	12	515	605	KK 25A	143	134	M32 x 1.5	4L
ARC 132 M	10	10	41	41	132	20	332	12	12	515	605	KK 25A	143	134	M32 x 1.5	4L
ARC 160 S	14	12	51.5	45	160	25	390	15	15	540	658	KK 25A	143	134	M32 x 1.5	4L
ARC 160 M	14	12	51.5	45	160	25	390	15	15	540	658	KK 25A	143	134	M32 x 1.5	4L
ARC 160 MX	14	12	51.5	45	160	25	390	15	15	592	710	KK 25A	143	134	M32 x 1.5	4L
ARC 160 L	14	12	51.5	45	160	25	390	15	15	592	710	KK 25A	143	134	M32 x 1.5	4L
ARC 180 S	16	14	59	51.5	180	25	441	15	15	610	730	KK 63A	175	162	M40 x 1.5	4L
ARC 180 M	16	14	59	51.5	180	25	441	15	15	610	730	KK 63A	175	162	M40 x 1.5	4L
ARC 180 L	16	14	59	51.5	180	25	441	15	15	694	814	KK 63A	175	162	M40 x 1.5	4L
ARC 200 M	18	16	64	59	200	27	500	19	19	845	965	KK 100A	213	207	M50 x 1.5	8L
ARC 200 L	18	16	64	59	200	27	500	19	19	845	965	KK 100A	213	207	M50 x 1.5	8L
ARC 225 M	18	16	69	59	225	30	551	19	19	815	935	KK 100A	213	207	M50 x 1.5	8L
ARC 250 S	20	18	79.5	69	250	33	638	24	24	840	990	KK 200A	282	242	M63 x 1.5	8L
ARC 250 M	20	18	79.5	69	250	33	638	24	24	840	990	KK 200A	282	242	M63 x 1.5	8L
ARC 280 S	22	20	85	74.5	280	40	700	24	24	970	1120	KK 200A	282	242	M63 x 1.5	8L
ARC 280 M	22	20	85	74.5	280	40	700	24	24	970	1120	KK 200A	282	242	M63 x 1.5	8L
ARC 315 M	25	20	95	79.5	315	44	757	28	28	1275	1415	KK 200A	282	242	M63 x 1.5	8L
ARC 315 L	25	20	95	79.5	315	44	757	28	35	1275	1415	KK 200A	282	242	M63 x 1.5	8L
ARC 355 MY	28	22	106	85	355	50	915	28	35	1400	1580	KK 400A	311	294	M63 x 1.5	8L
ARC 355 M	28	22	106	85	355	50	915	28	35	1400	1580	KK 400A	311	294	M63 x 1.5	8L
ARC 355 MX	28	22	106	85	355	50	915	28	35	1400	1580	KK 400A	311	294	M63 x 1.5	8L
ARC 355 L	28	22	106	85	355	50	915	28	35	1400	1580	KK 400A	311	294	M63 x 1.5	8L
ARC 400 L	28	25	116	95	400	55	1006	35	35	1630	1820	KK 400B	415	340	M63 x 1.5	8L

Three-phase roller table motors with squirrel-cage rotor Efficiency class "High Efficiency" acc. to EN 60034-30

Sizes 56 to 280,
with surface cooling, type of cooling IC 411, type of protection IP 55

Type of construction IM B3 [IM 1001]

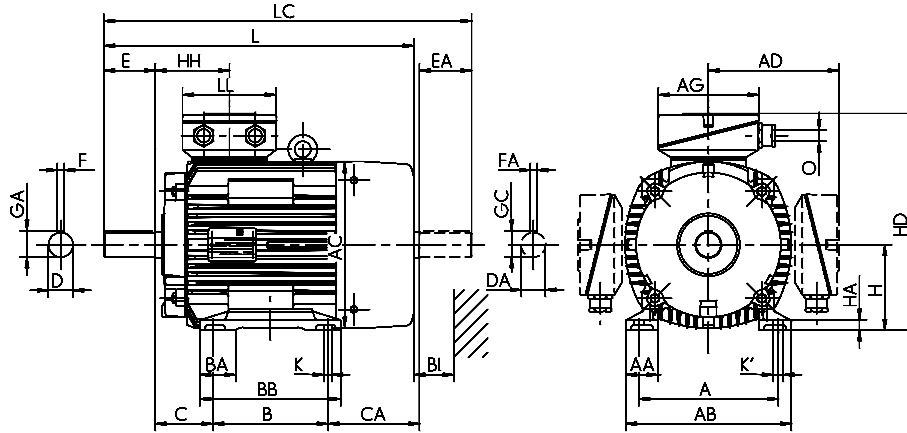

Type designation	Flange size	A	AA	AB	AC	AD ^(*)	B	BA	BB	C	CA	D	DA	DB ^(*)	E	EA	F	FA
		b	n	f	g	g1	a	m	e	w1	w2	d	d1		l	l1	u	u1
AE1R 56 K2, 4	FF 100	90	18	110	109	-	71	-	86	36	52	9	9	M3	20	20	3	3
AE1R 56 G2, 4	FF 100	90	18	110	109	-	71	-	86	36	52	9	9	M3	20	20	3	3
AE1R 63 K2, 4	FF 115	100	21	120	124	-	80	-	95	40	59	11	11	M4	23	23	4	4
AE1R 63 G2, 4	FF 115	100	21	120	124	-	80	-	95	40	59	11	11	M4	23	23	4	4
AE1R 71 K2, 4, 6	FF 130	112	23	135	139	-	90	-	114	45	78	14	14	M5	30	30	5	5
AE1R 71 G2, 4, 6	FF 130	112	23	135	139	-	90	-	114	45	78	14	14	M5	30	30	5	5
IE2-AE1R 80 K2, 4, 6, 8	FF 165	125	26	152	157	-	100	-	124	50	80	19	19	M6	40	40	6	6
IE2-AE1R 80 G2	FF 165	125	26	152	157	-	100	-	146	50	102	19	19	M6	40	40	6	6
IE2-AE1R 80 G4, 6, 8	FF 165	125	26	152	157	-	100	-	146	50	102	19	19	M6	40	40	6	6
IE2-AE1R 90 S2, 4	FF 165	140	25	167	177	-	100	-	150	56	120	24	24	M8	50	50	8	8
IE2-AE1R 90 S6, 8	FF 165	140	25	167	177	-	100	-	150	56	120	24	24	M8	50	50	8	8
IE2-AE1R 90 L2	FF 165	140	25	167	177	-	125	-	150	56	95	24	24	M8	50	50	8	8
IE2-AE1R 90 LV4	FF 165	140	25	167	177	-	125	-	150	56	135	24	24	M8	50	50	8	8
IE2-AE1R 90 LV6, 8	FF 165	140	25	167	177	-	125	-	150	56	135	24	24	M8	50	50	8	8
IE2-AE1R 100 S8	FF 215	160	32	188	196	-	140	-	171	63	102	28	28	M10	60	60	8	8
IE2-AE1R 100 L2	FF 215	160	32	188	196	-	140	-	171	63	102	28	28	M10	60	60	8	8
IE2-AE1R 100 L4	FF 215	160	32	188	196	-	140	-	205	63	136	28	28	M10	60	60	8	8
IE2-AE1R 100 LX4	FF 215	160	40	188	196	-	140	-	180	63	159	28	28	M10	60	60	8	8
IE2-AE1R 100 LX6, 8	FF 215	160	32	224	196	-	140	-	180	63	136	28	28	M10	60	60	8	8
IE2-AE1R 112 MX2	FF 215	190	50	224	196	-	140	-	180	70	129	28	28	M10	60	60	8	8
IE2-AE1R 112 MZ4	FF 215	190	50	224	196	-	140	-	180	70	199	28	28	M10	60	60	8	8
IE2-AE1R 112 MV2, 6, 8	FF 215	190	50	224	196	-	140	-	180	70	159	28	28	M10	60	60	8	8
IE2-AE1R 132 S2 T	FF 265	216	50	256	196	-	140	-	180	89	159	38	28	M12	80	80	10	10
IE2-AE1R 132 S2																		
IE2-AE1R 132 SX2	FF 265	216	50	256	258	199	140	55	180	89	176	38	32	M12	80	80	10	10
IE2-AE2R 132 S4	FF 265	216	50	256	217	178	140	55	180	89	223	38	32	M12	80	80	10	10
IE2-AE1R 132 S6, 8	FF 265	216	50	256	217	178	140	55	180	89	173	38	32	M12	80	80	10	10
IE2-AE1R 132 M4	FF 265	216	50	256	258	199	178	55	218	89	186	38	38	M12	80	80	10	10
IE2-AE2R 132 M6, 8	FF 265	216	50	256	217	178	178	55	218	89	185	38	32	M12	80	80	10	10
IE2-AE1R 132 M6, 8	FF 265	216	50	256	258	199	178	55	218	89	138	38	32	M12	80	80	10	10
IE2-AE1R 132 MX6	FF 265	216	50	256	258	199	178	55	218	89	186	38	38	M12	80	80	10	10
IE2-AE1R 160 M2	FF 300	254	55	296	313	242	210	60	257	108	148	42	38	M16	110	80	12	10
IE2-AE2R 160 M4	FF 300	254	55	296	258	214	210	60	257	108	185	42	38	M16	110	80	12	10
IE2-AE1R 160 M8	FF 300	254	55	296	258	214	210	60	257	108	135	42	38	M16	110	80	12	10
IE2-AE2R 160 M6, MX8	FF 300	254	55	296	258	214	210	60	257	108	185	42	38	M16	110	80	12	10
IE2-AE1R 160 MX2	FF 300	254	55	296	313	242	210	56	257	108	185	42	42	M16	110	110	12	12
IE2-AE1R 160 L2	FF 300	254	55	296	313	242	254	60	301	108	142	42	42	M16	110	110	12	12
IE2-AE2R 160 L4	FF 300	254	55	296	313	242	254	60	301	108	192	42	42	M16	110	110	12	12
IE2-AE1R 160 L6, 8	FF 300	254	55	296	313	242	254	60	301	108	142	42	42	M16	110	110	12	12
IE2-AE1R 180 M2	FF 300	279	62	328	351	261	241	65	288	121	169	48	48	M16	110	110	14	14
IE2-AE2R 180 M4	FF 300	279	62	328	351	261	241	65	288	121	194	48	48	M16	110	110	14	14
IE2-AE1R 180 L4	FF 300	279	62	328	351	261	279	65	326	121	176	48	48	M16	110	110	14	14
IE2-AE1R 180 L6, 8	FF 300	279	62	328	351	261	279	65	326	121	176	48	42	M16	110	110	14	14
IE2-AE1R 200 L2	FF 350	318	70	372	351	261	305	70	360	133	138	55	48	M20	110	110	16	14
IE2-AE2R 200 LX2	FF 350	318	70	372	351	261	305	70	360	133	188	55	48	M20	110	110	16	14
IE2-AE1R 200 L4	FF 350	318	70	372	390	300	305	70	360	133	193	55	55	M20	110	110	16	16
IE2-AE1R 200 LX6	FF 350	318	70	372	390	300	305	70	360	133	193	55	55	M20	110	110	16	16
IE2-AE1R 200 L6, 8	FF 350	318	70	372	351	261	305	70	360	133	138	55	48	M20	110	110	16	14
IE2-AE1R 225 M2	FF 400	356	75	413	390	300	311	75	368	149	211	55	55	M20	110	110	16	16
IE2-AE1R 225 S4	FF 400	356	75	413	390	300	286	75	343	149	196	60	55	M20	140	110	18	16
IE2-AE2R 225 M4	FF 400	356	75	413	390	300	311	75	343	149	261	60	55	M20	140	110	18	16
IE2-AE1R 225 S8	FF 400	356	75	413	390	300	286	75	368	149	211	60	55	M20	140	110	18	16
IE2-AE2R 225 M6, 8	FF 400	356	75	413	390	300	311	75	368	149	221	60	55	M20	140	110	18	16
IE2-AE1R 250 M2	FF 500	406	84	471	440	358	349	84	412	168	210	60	55	M20	140	110	18	16
IE2-AE1R 250 M4	FF 500	406	84	469	490	386	349	84	412	168	275	65	55	M20	140	110	18	16
IE2-AE2R 250 M4, 6	FF 500	406	84	469	440	386	349	84	412	168	325	65	55	M20	140	110	18	16
IE2-AE1R 280 S2	FF 500	457	94	522	490	386	368	96	431	190	234	65	65	M20	140	140	18	18
IE2-AE1R 280 M2	FF 500	457	94	522	490	386	419	96	482	190	229	65	65	M20	140	140	18	18
IE2-AE1R 280 S4	FF 500	457	94	522	490	386	368	96	431	190	234	75	65	M20	140	140	20	18
IE2-AE1R 280 M4	FF 500	457	94	522	490	386	419	96	482	190	229	75	65	M20	140	140	20	18
IE2-AE1R 280 S6	FF 500	457	94	522	490	386	368	96	431	190	229	75	65	M20	140	140	20	18
IE2-AE1R 280 S8	FF 500	457	94	522	490	386	368	96	431	190	229	75	65	M20	140	140	20	18
IE2-AE1R 280 M6, 8	FF 500	457	88	522	550	416	419	94	482	190	384	75	65	M20	140	140	20	18

^{*)} Centre holes to DIN 332-DS

^(*) Terminal box left/right

Three-phase roller table motors with squirrel-cage rotor Efficiency class "High Efficiency" acc. to EN 60034-30

Sizes 56 to 280,
with surface cooling, type of cooling IC 411, type of protection IP 55

Type of construction IM B35 [IM 2001]

Flange dimensions, see page 56

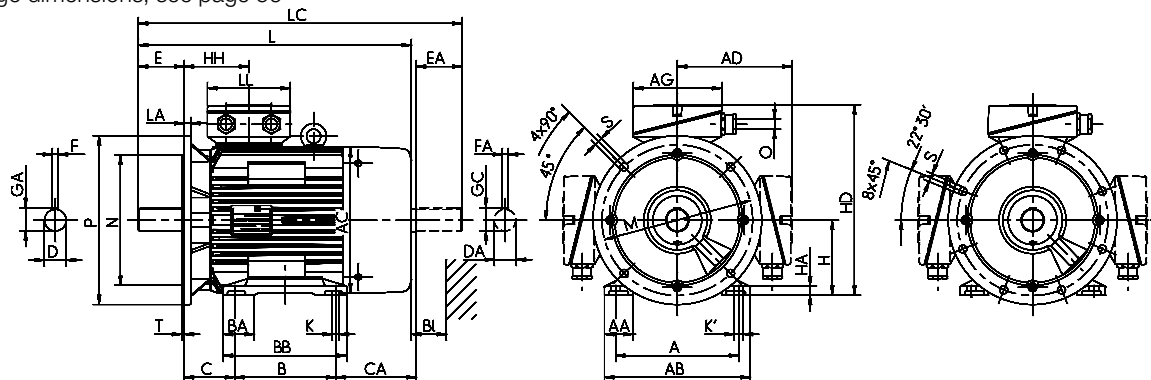

Type designation	GA t	GC t1	H h	HA c	HD p	HD'' p	HH A	K s	K' s'	L k	LC k1	KK Type	AG x	LL z	O -	Hole pattern	BI BI
AE1R 56 K2, 4	10.2	10.2	56	7	154	on request	58	6	6	176	199	KA 05	92	92	M20 x 1.5	4L	14
AE1R 56 G2, 4	10.2	10.2	56	7	154	on request	58	6	6	176	199	KA 05	92	92	M20 x 1.5	4L	14
AE1R 63 K2, 4	12.5	12.5	63	7.5	167	on request	61	7	7	199	225	KA 05	92	92	M20 x 1.5	4L	14
AE1R 63 G2, 4	12.5	12.5	63	7.5	167	on request	61	7	7	199	225	KA 05	92	92	M20 x 1.5	4L	14
AE1R 71 K2, 4, 6	16	16	71	8	182	on request	67	7	7	239	273	KA 05	92	92	M20 x 1.5	4L	16
AE1R 71 G2, 4, 6	16	16	71	8	182	on request	67	7	7	239	273	KA 05	92	92	M20 x 1.5	4L	16
IE2-AE1R 80 K2, 4, 6, 8	21.5	21.5	80	9	200	on request	70	10	10	265	310	KA 05	92	92	M20 x 1.5	4L	16
IE2-AE1R 80 G2	21.5	21.5	80	9	200	on request	70	10	10	287	332	KA 05	92	92	M20 x 1.5	4L	16
IE2-AE1R 80 G4, 6, 8	21.5	21.5	80	9	200	on request	70	10	10	287	332	KA 05	92	92	M20 x 1.5	4L	16
IE2-AE1R 90 S2, 4	27	27	90	9.5	217	on request	75	10	10	321	376	KA 05	92	92	M25 x 1.5	4L	18
IE2-AE1R 90 S6, 8	27	27	90	9.5	217	on request	75	10	10	321	376	KA 05	92	92	M25 x 1.5	4L	18
IE2-AE1R 90 L2	27	27	90	9.5	217	on request	75	10	10	321	376	KA 05	92	92	M25 x 1.5	4L	18
IE2-AE1R 90 LV4	27	27	90	9.5	217	on request	75	10	10	362	416	KA 05	92	92	M25 x 1.5	4L	18
IE2-AE1R 90 LV6, 8	27	27	90	9.5	217	on request	75	10	10	362	416	KA 05	92	92	M25 x 1.5	4L	18
IE2-AE1R 100 S8	31	31	100	11	237	on request	77	12	12	357	425	KA 05	92	92	M25 x 1.5	4L	20
IE2-AE1R 100 L2	31	31	100	11	237	on request	77	12	12	357	425	KA 05	92	92	M25 x 1.5	4L	20
IE2-AE1R 100 L4	31	31	100	11	237	on request	77	12	12	391	459	KA 05	92	92	M25 x 1.5	4L	20
IE2-AE1R 100 LX4	31	31	100	18	249	on request	77	12	12	421	489	KA 05	92	92	M25 x 1.5	4L	20
IE2-AE1R 100 LX6, 8	31	31	100	18	249	on request	77	12	12	357	425	KA 05	92	92	M25 x 1.5	4L	20
IE2-AE1R 112 MX2	31	31	112	18	249	on request	77	12	12	391	459	KA 05	92	92	M25 x 1.5	4L	20
IE2-AE1R 112 MZ4	31	31	112	18	249	on request	77	12	12	461	529	KA 05	92	92	M25 x 1.5	4L	20
IE2-AE1R 112 MV2, 6, 8	31	31	112	18	249	on request	77	12	12	421	489	KA 05	92	92	M25 x 1.5	4L	20
IE2-AE1R 132 S2 T	41	41	132	18	287	on request	96	12	12	460	528	KK Ex	104	112	M32 x 1.5	4L	20
IE2-AE1R 132 SX2	41	41	132	15	331	on request	114	12	12	481	565	KK 25 A	156	145	M32 x 1.5	4L	35
IE2-AE2R 132 S4	41	35	132	16	310	on request	108	12	12	529	612	KK 25 A	156	145	M32 x 1.5	4L	35
IE2-AE1R 132 S6, 8	41	35	132	16	310	on request	108	12	12	479	562	KK 25 A	156	145	M32 x 1.5	4L	35
IE2-AE1R 132 M4	41	41	132	15	331	on request	114	12	12	529	613	KK 25 A	156	145	M32 x 1.5	4L	35
IE2-AE2R 132 M6, 8	41	35	132	16	310	on request	108	12	12	529	612	KK 25 A	156	145	M32 x 1.5	4L	35
IE2-AE1R 132 M6, 8	41	41	132	16	331	on request	114	12	12	481	565	KK 25 A	156	145	M32 x 1.5	4L	35
IE2-AE1R 132 MX6	41	41	132	15	331	on request	114	12	12	529	613	KK 25 A	156	145	M32 x 1.5	4L	35
IE2-AE1R 160 M2	45	41	160	18	402	on request	138	15	20	571	656	KK 63 A	193	167	M40 x 1.5	4L	35
IE2-AE2R 160 M4	45	41	160	18	374	on request	114	15	15	609	693	KK 63 A	193	167	M40 x 1.5	4L	35
IE2-AE1R 160 M8	45	41	160	18	374	on request	138	15	15	559	643	KK 63 A	193	167	M40 x 1.5	4L	35
IE2-AE2R 160 M6, MX8	45	41	160	18	374	on request	114	15	15	609	693	KK 63 A	193	167	M40 x 1.5	4L	35
IE2-AE1R 160 MX2	45	45	160	18	402	on request	138	15	20	609	724	KK 63 A	193	167	M40 x 1.5	4L	35
IE2-AE1R 160 L2	45	45	160	18	402	on request	138	15	20	609	724	KK 63 A	193	167	M40 x 1.5	4L	35
IE2-AE2R 160 L4	45	45	160	18	402	on request	138	15	20	659	774	KK 63 A	193	167	M40 x 1.5	4L	35
IE2-AE1R 160 L6, 8	45	45	160	18	402	on request	138	15	20	609	724	KK 63 A	193	167	M40 x 1.5	4L	35
IE2-AE1R 180 M2	51.5	51.5	180	20	441	on request	147	15	20	635	751	KK 63 A	193	167	M40 x 1.5	4L	35
IE2-AE2R 180 M4	51.5	51.5	180	20	441	on request	147	15	20	635	751	KK 63 A	193	167	M40 x 1.5	4L	35
IE2-AE1R 180 L4	51.5	51.5	180	20	441	on request	147	15	20	680	796	KK 63 A	193	167	M40 x 1.5	4L	35
IE2-AE1R 180 L6, 8	51.5	45	180	20	441	on request	147	15	20	680	796	KK 63 A	193	167	M40 x 1.5	4L	35
IE2-AE1R 200 L2	59	51.5	200	22	461	on request	147	19	25	680	796	KK 63 A	193	167	M50 x 1.5	4L	35
IE2-AE2R 200 LX2	59	51.5	200	22	461	on request	147	19	25	730	846	KK 63 A	193	167	M50 x 1.5	4L	35
IE2-AE1R 200 L4	59	59	200	22	500	on request	168	19	25	727	851	KK 100 A	213	207	M50 x 1.5	4L	35
IE2-AE1R 200 LX6	59	59	200	22	500	on request	168	19	25	727	851	KK 100 A	213	207	M50 x 1.5	4L	35
IE2-AE1R 200 L6, 8	59	51.5	200	22	461	on request	147	19	25	680	796	KK 63 A	193	167	M50 x 1.5	4L	35
IE2-AE1R 225 M2	59	59	225	25	527	on request	168	19	25	767	891	KK 100 A	213	207	M50 x 1.5	8L	40
IE2-AE1R 225 S4	64	59	225	25	527	on request	168	19	25	797	921	KK 100 A	213	207	M50 x 1.5	8L	40
IE2-AE2R 225 M4	64	59	225	25	527	on request	168	19	25	847	971	KK 100 A	213	207	M50 x 1.5	8L	40
IE2-AE1R 225 S8	64	59	225	25	527	on request	168	19	25	797	921	KK 100 A	213	207	M50 x 1.5	8L	40
IE2-AE2R 225 M6, 8	64	59	225	25	527	on request	168	19	25	797	921	KK 100 A	213	207	M50 x 1.5	8L	40
IE2-AE1R 250 M2	64	59	250	28	608	on request	177	24	30	862	977	KK 200 A	282	242	M63 x 1.5	8L	45
IE2-AE1R 250 M4	69	59	250	28	636	on request	206	24	30	924	1042	KK 200 A	282	242	M63 x 1.5	8L	50
IE2-AE2R 250 M4	69	59	250	28	636	on request	177	24	30	912	1027	KK 200 A	282	242	M63 x 1.5	8L	50
IE2-AE1R 280 S2	69	69	280	32	666	on request	206	24	30	924	1072	KK 200 A	282	242	M63 x 1.5	8L	50
IE2-AE1R 280 M2	69	69	280	32	666	on request	206	24	30	970	1118	KK 200 A	282	242	M63 x 1.5	8L	50
IE2-AE1R 280 S4	79.5	69	280	32	666	on request	206	24	30	924	1072	KK 200 A	282	242	M63 x 1.5	8L	50
IE2-AE1R 280 M4	79.5	69	280	32	666	on request	206	24	30	970	1118	KK 200 A	282	242	M63 x 1.5	8L	50
IE2-AE1R 280 S6	79.5	69	280	32	666	on request	206	24	30	970	1118	KK 200 A	282	242	M63 x 1.5	8L	50
IE2-AE1R 280 S8	79.5	69	280	32	666	on request	206	24	30	970	1118	KK 200 A	282	242	M63 x 1.5	8L	50
IE2-AE1R 280 M6, 8	79.5	69	280	40	696	on request	211	24	30	1105	1273	KK 200 A	282	242	M63 x 1.5	8L	55

*) Terminal box left/right

Sizes 56/63/71/90: Deviating dimensions C, HH, L, LC for B35, see B5

Three-phase roller table motors with squirrel-cage rotor Efficiency class “High Efficiency” acc. to EN 60034-30

Sizes 315

with surface cooling, type of cooling IC 411, type of protection IP 55

Type of construction IM B3 [IM 1001]

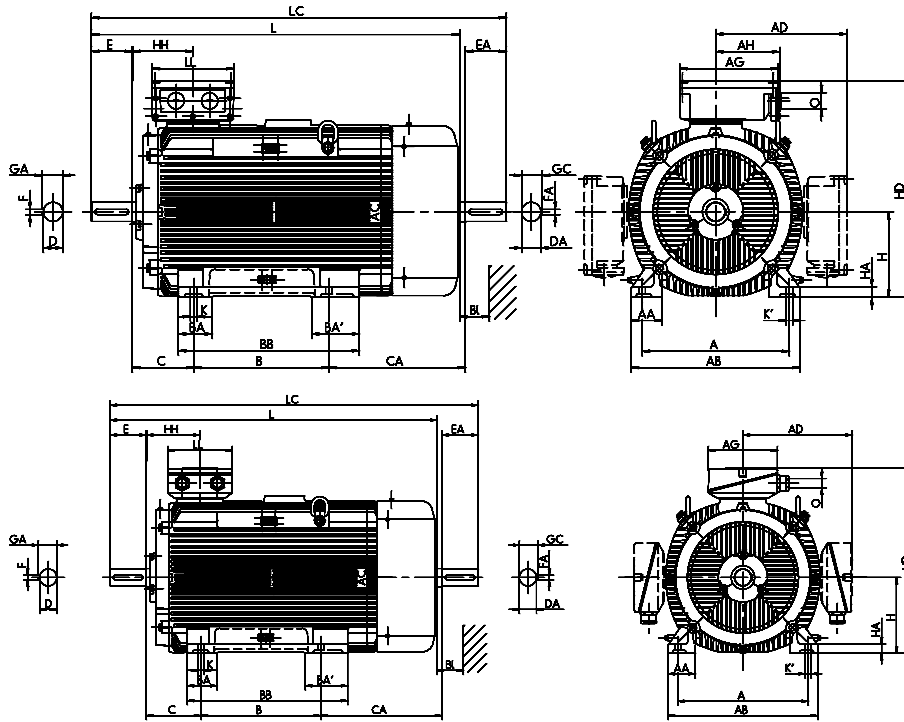

Type designation	Flange size	A	AA	AB	AC	AD ^(*)	B	BA	BA'	BB	C	CA	D	DA	DB ^(*)	E	EA	F	FA
		b	n	f	g	g1	a	m	m1	e	w1	w2	d	d1		l	l1	u	u1
IE2-AE1R 315 S2	FF 600	508	126	590	550	416	406	120	-	503	216	316	65	65	M20	140	140	18	18
IE2-AE1R 315 M2	FF 600	508	126	590	550	416	457	120	150	554	216	320	65	65	M20	140	140	18	18
IE2-AE1R 315 MX2	FF 600	508	126	590	550	416	457	120	150	554	216	400	65	65	M20	140	140	18	18
IE2-AE1R 315 MY2	FF 600	508	110	590	610	498	457	120	-	573	216	495	65	65	M20	140	140	18	18
IE2-AE1R 315 L2	FF 600	508	110	590	610	498	508	120	-	624	216	539	65	65	M20	140	140	18	18
IE2-AE1R 315 LX2	FF 600	508	110	590	610	498	508	120	-	624	216	684	65	65	M20	140	140	18	18
IE2-AE1R 315 S4	FF 600	508	126	590	550	416	406	120	-	503	216	316	80	70	M20	170	140	22	20
IE2-AE1R 315 M4	FF 600	508	126	590	550	416	457	120	150	554	216	320	80	70	M20	170	140	22	20
IE2-AE1R 315 MX4	FF 600	508	126	590	550	416	457	120	150	554	216	400	80	70	M20	170	140	22	20
IE2-AE1R 315 MY4	FF 600	508	110	590	610	498	457	120	-	573	216	495	80	70	M20	170	140	22	20
IE2-AE1R 315 L4	FF 600	508	110	590	610	498	508	120	-	624	216	564	80	70	M20	170	140	22	20
IE2-AE1R 315 LX4	FF 600	508	110	590	610	498	508	120	-	624	216	689	80	70	M20	170	140	22	20
IE2-AE1R 315 S6	FF 600	508	126	590	550	416	406	120	150	554	216	320	80	70	M20	170	140	22	20
IE2-AE1R 315 M6	FF 600	508	126	590	550	416	457	120	150	554	216	320	80	70	M20	170	140	22	20
IE2-AE1R 315 MX6	FF 600	508	110	590	610	498	457	120	-	573	216	495	80	70	M20	170	140	22	20
IE2-AE1R 315 MY6	FF 600	508	110	590	610	498	457	120	-	573	216	495	80	70	M20	170	140	22	20
IE2-AE1R 315 L6	FF 600	508	110	590	610	498	508	120	-	624	216	564	80	70	M20	170	140	22	20
IE2-AE1R 315 LX6	FF 600	508	110	590	610	498	508	120	-	624	216	564	80	70	M20	170	140	22	20
IE2-AE1R 315 S8	FF 600	508	126	590	550	416	406	120	150	554	216	320	80	70	M20	170	140	22	20
IE2-AE1R 315 M8	FF 600	508	126	590	550	416	457	120	150	554	216	320	80	70	M20	170	140	22	20
IE2-AE1R 315 MX8	FF 600	508	110	590	610	498	457	120	-	573	216	495	80	70	M20	170	140	22	20
IE2-AE1R 315 MY8	FF 600	508	110	590	610	498	457	120	-	573	216	495	80	70	M20	170	140	22	20
IE2-AE1R 315 L8	FF 600	508	110	590	610	498	508	120	-	624	216	564	80	70	M20	170	140	22	20
IE2-AE1R 315 LX8	FF 600	508	110	590	610	498	508	120	-	624	216	564	80	70	M20	170	140	22	20

^{*)} Centre holes to DIN 332-DS

^(**) Terminal box left/right

Three-phase roller table motors with squirrel-cage rotor Efficiency class “High Efficiency” acc. to EN 60034-30

Sizes 315
with surface cooling, type of cooling IC 411, type of protection IP 55

Type of construction IM B35 [IM 2001]

Flange dimensions, see page 56

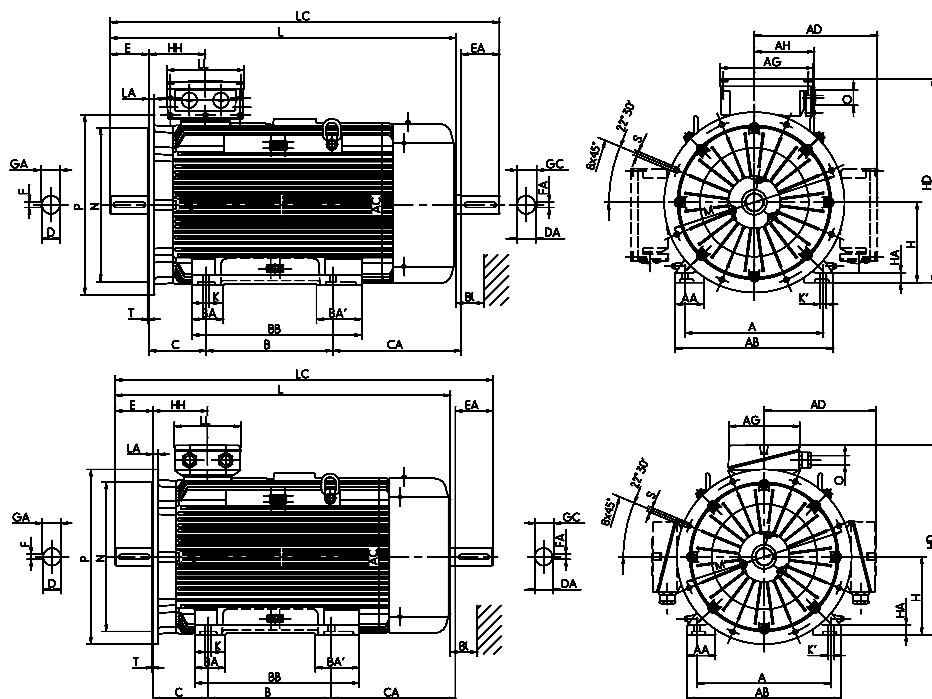

Type designation	GA	GC	H	HA	HD	HD ^{*)}	HH	K	K'	L	LC	KK Type	AG	LL	O	Hole pattern	BI
	t	t1	h	c	p	p	A	s	s'	k	k1		x	z	-		BI
IE2-AE1R 315 S2	69	69	315	44	731	595	211	28	35	1050	1218	KK 200 A	282	242	-	M63 x 1.5	55
IE2-AE1R 315 M2	69	69	315	44	731	595	211	28	35	1105	1273	KK 200 A	282	242	-	M63 x 1.5	55
IE2-AE1R 315 MX2	69	69	315	44	731	595	211	28	35	1185	1353	KK 200 A	282	242	-	M63 x 1.5	55
IE2-AE1R 315 MY2	69	69	315	44	809	628	230	28	35	1270	1448	KK 400 B	415	340	265	M63 x 1.5	55
IE2-AE1R 315 L2	69	69	315	44	809	628	230	28	35	1390	1568	KK 400 B	415	340	265	M63 x 1.5	55
IE2-AE1R 315 LX2	69	69	315	44	809	628	230	28	35	1510	1688	KK 400 B	415	340	265	M63 x 1.5	55
IE2-AE1R 315 S4	85	74.5	315	44	731	595	211	28	35	1080	1248	KK 200 A	282	242	-	M63 x 1.5	55
IE2-AE1R 315 M4	85	74.5	315	44	731	595	211	28	35	1135	1303	KK 200 A	282	242	-	M63 x 1.5	55
IE2-AE1R 315 MX4	85	74.5	315	44	731	595	211	28	35	1215	1383	KK 200 A	282	242	-	M63 x 1.5	55
IE2-AE1R 315 MY4	85	74.5	315	44	809	628	230	28	35	1300	1478	KK 400 B	415	340	265	M63 x 1.5	55
IE2-AE1R 315 L4	85	74.5	315	44	809	628	230	28	35	1420	1598	KK 400 B	415	340	265	M63 x 1.5	55
IE2-AE1R 315 LX4	85	74.5	315	44	809	628	230	28	35	1540	1718	KK 400 B	415	340	265	M63 x 1.5	55
IE2-AE1R 315 S6	85	74.5	315	44	731	595	211	28	35	1135	1303	KK 200 A	282	242	-	M63 x 1.5	55
IE2-AE1R 315 M6	85	74.5	315	44	731	595	211	28	35	1135	1303	KK 200 A	282	242	265	M63 x 1.5	55
IE2-AE1R 315 MX6	85	74.5	315	44	809	628	230	28	35	1300	1478	KK 400 B	415	340	265	M63 x 1.5	55
IE2-AE1R 315 MY6	85	74.5	315	44	809	628	230	28	35	1300	1478	KK 400 B	415	340	265	M63 x 1.5	55
IE2-AE1R 315 L6	85	74.5	315	44	809	628	230	28	35	1420	1598	KK 400 B	415	340	265	M63 x 1.5	55
IE2-AE1R 315 LX6	85	74.5	315	44	809	628	230	28	35	1420	1598	KK 400 B	415	340	265	M63 x 1.5	55
IE2-AE1R 315 S8	85	74.5	315	44	731	595	211	28	35	1135	1303	KK 200 A	282	242	-	M63 x 1.5	55
IE2-AE1R 315 M8	85	74.5	315	44	731	595	211	28	35	1135	1303	KK 200 A	282	242	-	M63 x 1.5	55
IE2-AE1R 315 MX8	85	74.5	315	44	809	628	230	28	35	1300	1478	KK 400 B	415	340	265	M63 x 1.5	55
IE2-AE1R 315 MY8	85	74.5	315	44	809	628	230	28	35	1300	1478	KK 400 B	415	340	265	M63 x 1.5	55
IE2-AE1R 315 L8	85	74.5	315	44	809	628	230	28	35	1420	1598	KK 400 B	415	340	265	M63 x 1.5	55
IE2-AE1R 315 LX8	85	74.5	315	44	809	628	230	28	35	1420	1598	KK 400 B	415	340	265	M63 x 1.5	55

^{*)} Terminal box left/right

Three-phase roller table motors with squirrel-cage rotor Efficiency class “High Efficiency” acc. to EN 60034-30

Sizes 56 to 180,
with surface cooling, type of cooling IC 411, type of protection IP 55

Type of construction IM B14 [IM 3601]

Flange dimensions, see page 56

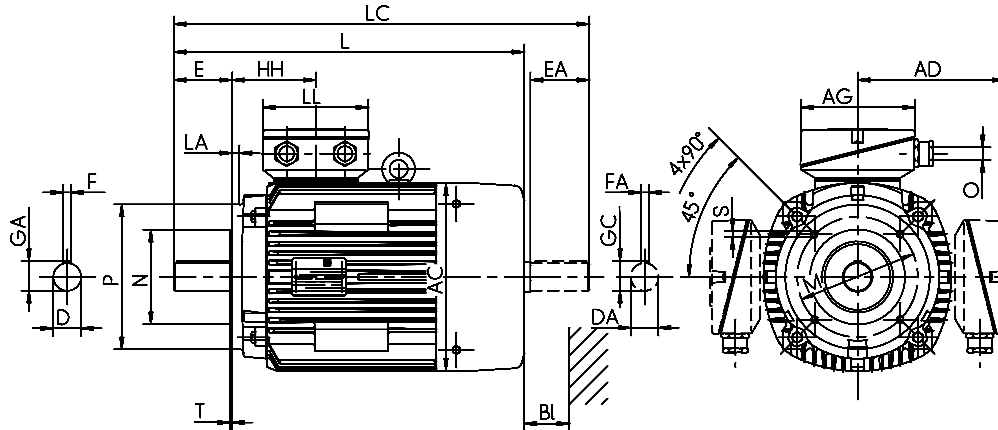

Type designation	Flange size		A	AA	AB	AC	AD ¹⁾	B	BA	BB	C	CA	D	DA	DB ²⁾	E	EA	F	FA
	small	big	b	n	f	g	g1	a	m	e	w1	w2	d	d1	l	l1	u	u1	
AE1R 56 K2, 4	FT 65	FT 85	90	18	110	109	-	71	-	86	36	52	9	9	M3	20	20	3	3
AE1R 56 G2, 4	FT 65	FT 85	90	18	110	109	-	71	-	86	36	52	9	9	M3	20	20	3	3
AE1R 63 K2, 4	FT 75	FT 85	100	21	120	124	-	80	-	95	40	59	11	11	M4	23	23	4	4
AE1R 63 G2, 4	FT 75	FT 85	100	21	120	124	-	80	-	95	40	59	11	11	M4	23	23	4	4
AE1R 71 K2, 4, 6	FT 85	FT 100	112	23	135	139	-	90	-	114	45	78	14	14	M5	30	30	5	5
AE1R 71 G2, 4, 6	FT 85	FT 100	112	23	135	139	-	90	-	114	45	78	14	14	M5	30	30	5	5
IE2-AE1R 80 K2, 4, 6, 8	FT 100	FT 115	125	26	152	157	-	100	-	124	50	80	19	19	M6	40	40	6	6
IE2-AE1R 80 G2	FT 100	FT 115	125	26	152	157	-	100	-	146	50	102	19	19	M6	40	40	6	6
IE2-AE1R 80 G4, 6, 8	FT 100	FT 115	125	26	152	157	-	100	-	146	50	102	19	19	M6	40	40	6	6
IE2-AE1R 90 S2, 4	FT 115	FT 130	140	25	167	177	-	100	-	150	56	120	24	24	M8	50	50	8	8
IE2-AE1R 90 S6, 8	FT 115	FT 130	140	25	167	177	-	100	-	150	56	120	24	24	M8	50	50	8	8
IE2-AE1R 90 L2	FT 115	FT 130	140	25	167	177	-	125	-	150	56	95	24	24	M8	50	50	8	8
IE2-AE1R 90 LV4	FT 115	FT 130	140	25	167	177	-	125	-	150	56	135	24	24	M8	50	50	8	8
IE2-AE1R 90 LV6, 8	FT 115	FT 130	140	25	167	177	-	125	-	150	56	135	24	24	M8	50	50	8	8
IE2-AE1R 100 S8	FT 130	FT 165	160	32	188	196	-	140	-	171	63	102	28	28	M10	60	60	8	8
IE2-AE1R 100 L2	FT 130	FT 165	160	32	188	196	-	140	-	171	63	102	28	28	M10	60	60	8	8
IE2-AE1R 100 L4	FT 130	FT 165	160	32	188	196	-	140	-	205	63	136	28	28	M10	60	60	8	8
IE2-AE1R 100 LX4	FT 130	FT 165	160	40	188	196	-	140	-	180	63	159	28	28	M10	60	60	8	8
IE2-AE1R 100 LX6, 8	FT 130	FT 165	160	32	224	196	-	140	-	180	63	136	28	28	M10	60	60	8	8
IE2-AE1R 112 MX2	FT 130	FT 165	190	50	224	196	-	140	-	180	70	129	28	28	M10	60	60	8	8
IE2-AE1R 112 MZ4	FT 130	FT 165	190	50	224	196	-	140	-	180	70	199	28	28	M10	60	60	8	8
IE2-AE1R 112 MV2, 6, 8	FT 130	FT 165	190	50	224	196	-	140	-	180	70	159	28	28	M10	60	60	8	8
IE2-AE1R 132 S2 T	FT 130	FT 165	216	50	256	196	-	140	-	180	89	159	38	28	M12	80	80	10	10
IE2-AE1R 132 S2	FT 130	FT 165	216	50	256	258	199	140	55	180	89	176	38	32	M12	80	80	10	10
IE2-AE2R 132 S4	FT 130	FT 165	216	50	256	217	178	140	55	180	89	223	38	32	M12	80	80	10	10
IE2-AE1R 132 S6, 8	FT 130	FT 165	216	50	256	217	178	140	55	180	89	173	38	32	M12	80	80	10	10
IE2-AE1R 132 M4	FT 165	FT 215	216	50	256	258	199	178	55	218	89	186	38	38	M12	80	80	10	10
IE2-AE2R 132 M6, 8	FT 130	FT 165	216	50	256	217	178	178	55	218	89	185	38	32	M12	80	80	10	10
IE2-AE1R 132 MX6	FT 165	FT 215	216	50	256	258	199	178	55	218	89	186	38	38	M12	80	80	10	10
IE2-AE1R 160 M2	FT 165	FT 215	254	55	296	258	214	210	60	257	108	185	42	38	M16	110	80	12	10
IE2-AE1R 160 M8	FT 165	FT 215	254	55	296	258	214	210	60	257	108	135	42	38	M16	110	80	12	10
IE2-AE2R 160 M4, 6, MX8	FT 165	FT 215	254	55	296	258	214	210	60	257	108	185	42	38	M16	110	80	12	10
IE2-AE1R 160 MX2	FT 215	FT 265	254	55	296	313	242	210	56	257	108	185	42	42	M16	110	110	12	12
IE2-AE1R 160 L2	FT 215	FT 265	254	55	296	313	242	254	60	301	108	142	42	42	M16	110	110	12	12
IE2-AE2R 160 L4	FT 215	FT 265	254	55	296	313	242	254	60	301	108	192	42	42	M16	110	110	12	12
IE2-AE1R 160 L6, 8	FT 215	FT 265	254	55	296	313	242	254	60	301	108	142	42	42	M16	110	110	12	12

¹⁾ Centre holes to DIN 332-DS

²⁾ Terminal box left/right

Three-phase roller table motors with squirrel-cage rotor Efficiency class “High Efficiency” acc. to EN 60034-30

Sizes 56 to 180,
with surface cooling, type of cooling IC 411, type of protection IP 55

Type of construction IM B34 [IM 2101]

Flange dimensions, see page 56

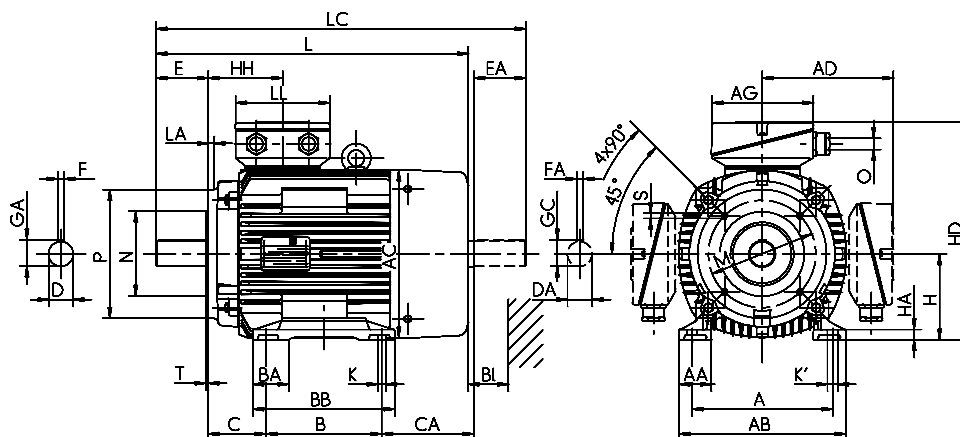

Type designation	GA	GC	H	HA	HD	HD ⁽¹⁾	HH	K	K'	L	LC	KK Type	AG	LL	O	Hole pattern	BI
	t	t1	h	c	p	p	A	s	s'	k	k1	x	z	-			
AE1R 56 K2, 4	10.2	10.2	56	7	154	on request	58	6	6	176	199	KA 05	92	92	M20 x 1.5	4L	14
AE1R 56 G2, 4	10.2	10.2	56	7	154	on request	58	6	6	176	199	KA 05	92	92	M20 x 1.5	4L	14
AE1R 63 K2, 4	12.5	12.5	63	7.5	167	on request	61	7	7	199	225	KA 05	92	92	M20 x 1.5	4L	14
AE1R 63 G2, 4	12.5	12.5	63	7.5	167	on request	61	7	7	199	225	KA 05	92	92	M20 x 1.5	4L	14
AE1R 71 K2, 4, 6	16	16	71	8	182	on request	67	7	7	239	273	KA 05	92	92	M20 x 1.5	4L	16
AE1R 71 G2, 4, 6	16	16	71	8	182	on request	67	7	7	239	273	KA 05	92	92	M20 x 1.5	4L	16
IE2-AE1R 80 K2, 4, 6, 8	21.5	21.5	80	9	200	on request	70	10	10	265	310	KA 05	92	92	M20 x 1.5	4L	16
IE2-AE1R 80 G2	21.5	21.5	80	9	200	on request	70	10	10	287	332	KA 05	92	92	M20 x 1.5	4L	16
IE2-AE1R 80 G4, 6, 8	21.5	21.5	80	9	200	on request	70	10	10	287	332	KA 05	92	92	M20 x 1.5	4L	16
IE2-AE1R 90 S2, 4	27	27	90	9.5	217	on request	75	10	10	321	376	KA 05	92	92	M25 x 1.5	4L	18
IE2-AE1R 90 S6, 8	27	27	90	9.5	217	on request	75	10	10	321	376	KA 05	92	92	M25 x 1.5	4L	18
IE2-AE1R 90 L2	27	27	90	9.5	217	on request	75	10	10	321	376	KA 05	92	92	M25 x 1.5	4L	18
IE2-AE1R 90 LV4	27	27	90	9.5	217	on request	75	10	10	362	416	KA 05	92	92	M25 x 1.5	4L	18
IE2-AE1R 90 LV6, 8	27	27	90	9.5	217	on request	75	10	10	362	416	KA 05	92	92	M25 x 1.5	4L	18
IE2-AE1R 100 S8	31	31	100	11	237	on request	77	12	12	357	425	KA 05	92	92	M25 x 1.5	4L	20
IE2-AE1R 100 L2	31	31	100	11	237	on request	77	12	12	357	425	KA 05	92	92	M25 x 1.5	4L	20
IE2-AE1R 100 L4	31	31	100	11	237	on request	77	12	12	391	459	KA 05	92	92	M25 x 1.5	4L	20
IE2-AE1R 100 LX4	31	31	100	18	249	on request	77	12	12	421	489	KA 05	92	92	M25 x 1.5	4L	20
IE2-AE1R 100 LX6, 8	31	31	100	18	249	on request	77	12	12	357	425	KA 05	92	92	M25 x 1.5	4L	20
IE2-AE1R 112 MX2	31	31	112	18	249	on request	77	12	12	391	459	KA 05	92	92	M25 x 1.5	4L	20
IE2-AE1R 112 MZ4	31	31	112	18	249	on request	77	12	12	461	529	KA 05	92	92	M25 x 1.5	4L	20
IE2-AE1R 112 MV2, 6, 8	31	31	112	18	249	on request	77	12	12	421	489	KA 05	92	92	M25 x 1.5	4L	20
IE2-AE1R 132 S2 T	41	31	132	18	287	on request	96	12	12	460	528	KK Ex	104	112	M32 x 1.5	4L	20
IE2-AE1R 132 SX2	41	41	132	15	331	on request	114	12	12	481	565	KK 25 A	156	145	M32 x 1.5	4L	35
IE2-AE2R 132 S4	41	35	132	16	310	on request	108	12	12	529	612	KK 25 A	156	145	M32 x 1.5	4L	35
IE2-AE1R 132 S6, 8	41	35	132	16	310	on request	108	12	12	479	562	KK 25 A	156	145	M32 x 1.5	4L	35
IE2-AE1R 132 M4	41	41	132	16	331	on request	114	12	12	529	613	KK 25 A	156	145	M32 x 1.5	4L	35
IE2-AE2R 132 M6, 8	41	35	132	16	310	on request	108	12	12	529	612	KK 25 A	156	145	M32 x 1.5	4L	35
IE2-AE1R 132 MX6	41	41	132	15	331	on request	114	12	12	529	613	KK 25 A	156	145	M32 x 1.5	4L	35
IE2-AE1R 160 M2	45	41	160	18	374	on request	114	15	15	605	689	KK 63 A	193	167	M40 x 1.5	4L	35
IE2-AE1R 160 M8	45	41	160	18	374	on request	138	15	15	559	643	KK 63 A	193	167	M40 x 1.5	4L	35
IE2-AE2R 160 M4, 6, MX8	45	41	160	18	374	on request	114	15	15	609	693	KK 63 A	193	167	M40 x 1.5	4L	35
IE2-AE1R 160 MX2	45	45	160	18	402	on request	138	15	20	609	724	KK 63 A	193	167	M40 x 1.5	4L	35
IE2-AE1R 160 L2	45	45	160	18	402	on request	138	15	20	609	724	KK 63 A	193	167	M40 x 1.5	4L	35
IE2-AE1R 160 L4	45	45	160	18	402	on request	138	15	20	659	774	KK 63 A	193	167	M40 x 1.5	4L	35
IE2-AE1R 160 L6, 8	45	45	160	18	402	on request	138	15	20	609	724	KK 63 A	193	167	M40 x 1.5	4L	35

⁽¹⁾ Terminal box left/right

Three-phase roller table motors with squirrel-cage rotor Efficiency class “High Efficiency” acc. to EN 60034-30

Sizes 56 to 280,
with surface cooling, type of cooling IC 411, type of protection IP 55

Type of construction IM B5 [IM 3001], Type of construction IM V1 [IM 3011]

Flange dimensions, see page 56

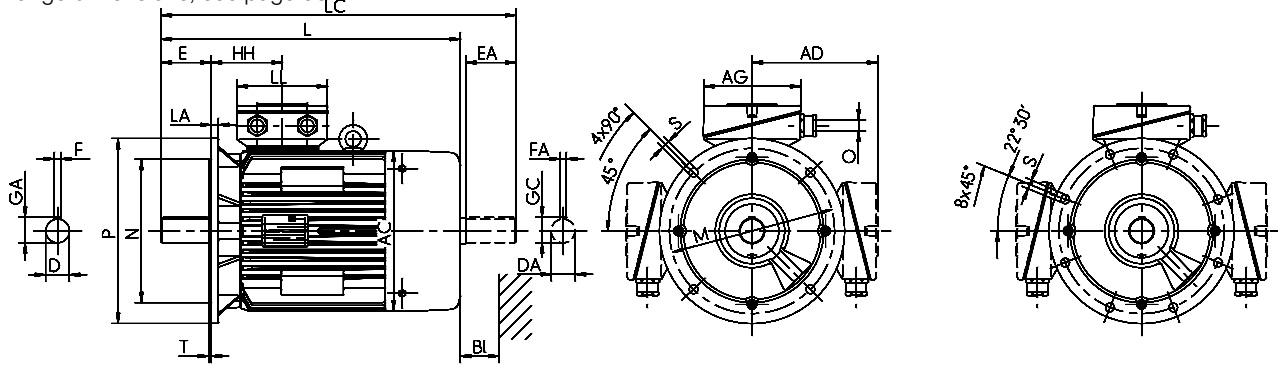

Type designation	Flange size	AC g	AD ^{*)} g1	D d	DA d1	DB ^{*)} d	E l	EA l1	F u	FA u1	GA t	GC t1	H h	HH A	L k	LC k1	KK Type	AG x	LL z	O -	Hole pattern BI
AE1R 56 K2, 4	FF 100	109	-	9	9	M3	20	20	3	3	10.2	10.2	56	81	199	222	KA 05	92	92	M20 x 1.5	4L 14
AE1R 56 G2, 4	FF 100	109	-	9	9	M3	20	20	3	3	10.2	10.2	56	81	199	222	KA 05	92	92	M20 x 1.5	4L 14
AE1R 63 K2, 4	FF 115	124	-	11	11	M4	23	23	4	4	12.5	12.5	63	94	232	258	KA 05	92	92	M20 x 1.5	4L 14
AE1R 63 G2, 4	FF 115	124	-	11	11	M4	23	23	4	4	12.5	12.5	63	94	232	258	KA 05	92	92	M20 x 1.5	4L 14
AE1R 71 K2, 4, 6	FF 130	139	-	14	14	M5	30	30	5	5	16	16	71	97	269	303	KA 05	92	92	M20 x 1.5	4L 16
AE1R 71 G2, 4, 6	FF 130	139	-	14	14	M5	30	30	5	5	16	16	71	97	269	303	KA 05	92	92	M20 x 1.5	4L 16
IE2-AE1R 80 K2, 4, 6, 8	FF 165	157	-	19	19	M6	40	40	6	6	21.5	21.5	80	70	265	310	KA 05	92	92	M20 x 1.5	4L 16
IE2-AE1R 80 G2	FF 165	157	-	19	19	M6	40	40	6	6	21.5	21.5	80	70	287	332	KA 05	92	92	M20 x 1.5	4L 16
IE2-AE1R 80 G4, 6, 8	FF 165	157	-	19	19	M6	40	40	6	6	21.5	21.5	80	70	287	332	KA 05	92	92	M20 x 1.5	4L 16
IE2-AE1R 90 S2, 4	FF 165	177	-	24	24	M8	50	50	8	8	27	27	90	114	360	425	KA 05	92	92	M25 x 1.5	4L 18
IE2-AE1R 90 S6, 8	FF 165	177	-	24	24	M8	50	50	8	8	27	27	90	114	360	425	KA 05	92	92	M25 x 1.5	4L 18
IE2-AE1R 90 L2	FF 165	177	-	24	24	M8	50	50	8	8	27	27	90	114	360	425	KA 05	92	92	M25 x 1.5	4L 18
IE2-AE1R 90 LV4	FF 165	177	-	24	24	M8	50	50	8	8	27	27	90	114	401	455	KA 05	92	92	M25 x 1.5	4L 18
IE2-AE1R 90 LV6, 8	FF 165	177	-	24	24	M8	50	50	8	8	27	27	90	114	401	455	KA 05	92	92	M25 x 1.5	4L 18
IE2-AE1R 100 S8	FF 215	196	-	28	28	M10	60	60	8	8	31	31	100	77	357	425	KA 05	92	92	M25 x 1.5	4L 20
IE2-AE1R 100 L2	FF 215	196	-	28	28	M10	60	60	8	8	31	31	100	77	357	425	KA 05	92	92	M25 x 1.5	4L 20
IE2-AE1R 100 L4	FF 215	196	-	28	28	M10	60	60	8	8	31	31	100	77	391	459	KA 05	92	92	M25 x 1.5	4L 20
IE2-AE1R 100 LX4	FF 215	196	-	28	28	M10	60	60	8	8	31	31	100	77	421	489	KA 05	92	92	M25 x 1.5	4L 20
IE2-AE1R 100 LX6, 8	FF 215	196	-	28	28	M10	60	60	8	8	31	31	100	77	391	459	KA 05	92	92	M25 x 1.5	4L 20
IE2-AE1R 112 MX2	FF 215	196	-	28	28	M10	60	60	8	8	31	31	112	77	391	459	KA 05	92	92	M25 x 1.5	4L 20
IE2-AE1R 112 MZ4	FF 215	196	-	28	28	M10	60	60	8	8	31	31	112	77	461	529	KA 05	92	92	M25 x 1.5	4L 20
IE2-AE1R 112 MV2, 6, 8	FF 215	196	-	28	28	M10	60	60	8	8	31	31	112	77	421	489	KA 05	92	92	M25 x 1.5	4L 20
IE2-AE1R 132 S2 T	FF 265	196	-	38	38	M12	80	80	10	8	41	41	132	96	460	528	KK Ex	104	112	M32 x 1.5	4L 20
IE2-AE1R 132 S2	FF 265	196	-	38	38	M12	80	80	10	10	41	41	132	114	481	565	KK 25 A	156	145	M32 x 1.5	4L 35
IE2-AE1R 132 SX2	FF 265	217	178	38	32	M12	80	80	10	10	41	35	132	108	529	612	KK 25 A	156	145	M32 x 1.5	4L 35
IE2-AE1R 132 S4	FF 265	217	178	38	32	M12	80	80	10	10	41	35	132	108	479	562	KK 25 A	156	145	M32 x 1.5	4L 35
IE2-AE1R 132 S6, 8	FF 265	217	178	38	32	M12	80	80	10	10	41	35	132	108	529	612	KK 25 A	156	145	M32 x 1.5	4L 35
IE2-AE1R 132 M4	FF 265	258	199	38	38	M12	80	80	10	10	41	41	132	114	529	613	KK 25 A	156	145	M32 x 1.5	4L 35
IE2-AE2R 132 M6, 8	FF 265	217	178	38	32	M12	80	80	10	10	41	35	132	108	529	612	KK 25 A	156	145	M32 x 1.5	4L 35
IE2-AE1R 132 MX6	FF 265	258	199	38	38	M12	80	80	10	10	41	41	132	114	529	613	KK 25 A	156	145	M32 x 1.5	4L 35
IE2-AE1R 160 M2	FF 300	313	242	42	38	M16	110	80	12	10	45	41	160	138	571	656	KK 63 A	193	167	M40 x 1.5	4L 35
IE2-AE1R 160 M8	FF 300	258	214	42	38	M16	110	80	12	10	45	41	160	138	559	643	KK 63 A	193	167	M40 x 1.5	4L 35
IE2-AE2R 160 M4, 6, MX8	FF 300	258	214	42	38	M16	110	80	12	10	45	41	160	114	609	693	KK 63 A	193	167	M40 x 1.5	4L 35
IE2-AE1R 160 MX2	FF 300	313	242	42	42	M16	110	110	12	12	45	45	160	138	609	724	KK 63 A	193	167	M40 x 1.5	4L 35
IE2-AE1R 160 L2	FF 300	313	242	42	42	M16	110	110	12	12	45	45	160	138	609	724	KK 63 A	193	167	M40 x 1.5	4L 35
IE2-AE1R 160 L4	FF 300	313	242	42	42	M16	110	110	12	12	45	45	160	138	659	774	KK 63 A	193	167	M40 x 1.5	4L 35
IE2-AE1R 160 L6, 8	FF 300	313	242	42	42	M16	110	110	12	12	45	45	160	138	609	724	KK 63 A	193	167	M40 x 1.5	4L 35
IE2-AE1R 180 M2	FF 300	351	261	48	48	M16	110	110	14	14	51.5	51.5	180	147	635	751	KK 63 A	193	167	M40 x 1.5	4L 35
IE2-AE2R 180 M4	FF 300	351	261	48	48	M16	110	110	14	14	51.5	51.5	180	147	635	751	KK 63 A	193	167	M40 x 1.5	4L 35
IE2-AE1R 180 L4	FF 300	351	261	48	48	M16	110	110	14	14	51.5	51.5	180	147	680	796	KK 63 A	193	167	M40 x 1.5	4L 35
IE2-AE1R 180 L6, 8	FF 300	351	261	48	42	M16	110	110	14	12	51.5	45	180	147	680	796	KK 63 A	193	167	M40 x 1.5	4L 35
IE2-AE1R 200 L2	FF 350	351	261	55	48	M20	110	110	16	14	59	51.5	200	147	680	796	KK 63 A	193	167	M50 x 1.5	4L 35
IE2-AE2R 200 LX2	FF 350	351	261	55	48	M20	110	110	16	14	59	51.5	200	147	730	846	KK 63 A	193	167	M50 x 1.5	4L 35
IE2-AE1R 200 L4	FF 350	390	300	55	55	M20	110	110	16	16	59	59	200	168	727	851	KK 100 A	213	207	M50 x 1.5	4L 35
IE2-AE1R 200 LX6	FF 350	390	300	55	55	M20	110	110	16	16	59	59	200	168	727	851	KK 100 A	213	207	M50 x 1.5	4L 35
IE2-AE1R 200 L6, 8	FF 350	351	261	55	48	M20	110	110	16	14	59	51.5	200	147	680	796	KK 63 A	193	167	M50 x 1.5	4L 35
IE2-AE1R 225 M2	FF 400	390	300	55	55	M20	140	110	16	16	59	59	225	168	767	891	KK 100 A	213	207	M50 x 1.5	8L 40
IE2-AE1R 225 S4	FF 400	390	300	60	55	M20	140	110	18	16	64	59	225	168	797	921	KK 100 A	213	207	M50 x 1.5	8L 40
IE2-AE2R 225 M4	FF 400	390	300	60	55	M20	140	110	18	16	64	59	225	168	847	971	KK 100 A	213	207	M50 x 1.5	8L 40
IE2-AE1R 225 S8	FF 400	390	300	60	55	M20	140	110	18	16	64	59	225	168	797	921	KK 100 A	213	207	M50 x 1.5	8L 40
IE2-AE2R 225 M6, 8	FF 400	390	300	60	55	M20	140	110	18	16	64	59	225	168	797	921	KK 100 A	213	207	M50 x 1.5	8L 40
IE2-AE1R 250 M2	FF 500	440	358	60	55	M20	140	110	18	16	64	59	250	177	862	977	KK 200 A	282	242	M63 x 1.5	8L 45
IE2-AE1R 250 M4	FF 500	490	386	65	55	M20	140	110	18	16	69	59	250	206	924	1042	KK 200 A	282	242	M63 x 1.5	8L 50
IE2-AE2R 250 M6, 8	FF 500	440	386	65	55	M20	140	110	18	16	69	59	250	177	912	1027	KK 200 A	282	242	M63 x 1.5	8L 50
IE2-AE1R 280 S2	FF 500	490	386	65	65	M20	140	140	18	18	69	69	280	206	924	1072	KK 200 A	282	242	M63 x 1.5	8L 50
IE2-AE1R 280 M2	FF 500	490	386	65	65	M20	140	140	18	18	69	69	280	206	970	1118	KK 200 A	282	242	M63 x 1.5	8L 50
IE2-AE1R 280 S4	FF 500	490	386	75	65	M20	140	140	20	18	79.5	69	280	206	924	1072	KK 200 A	282	242	M63 x 1.5	8L 50
IE2-AE1R 280 M4	FF 500	490	386	75	65	M20	140	140	20	18	79.5	69	280	206	970	1118	KK 200 A	282	242	M63 x 1.5	8L 50
IE2-AE1R 280 S6	FF 500	490	386	75	65	M20	140	140	20	18	79.5	69	280	206	970	1118	KK 200 A	282	242	M63 x 1.5	8L 50
IE2-AE1R 280 S8	FF 500	490	386	75	65	M20	140	140	20	18	79.5	69	280	206	970	1118	KK 200 A	282	242	M63 x 1.5	8L 50
IE2-AE1R 280 M6, 8	FF 500	550	416	75	65	M20	140	140	20	18	79.5	69	280	211	1105	1273	KK 200 A	282	242	M63 x 1.5	8L 55

^{*)} Centre holes to DIN 332-D5

^{**)} Terminal box left/right

Three-phase roller table motors with squirrel-cage rotor Efficiency class “High Efficiency” acc. to EN 60034-30

Sizes 315
with surface cooling, type of cooling IC 411, type of protection IP 55

Type of construction IM B5 [IM 3001] up to size 315 MY, Type of construction IM V1 [IM 3011]

Flange dimensions, see page 56

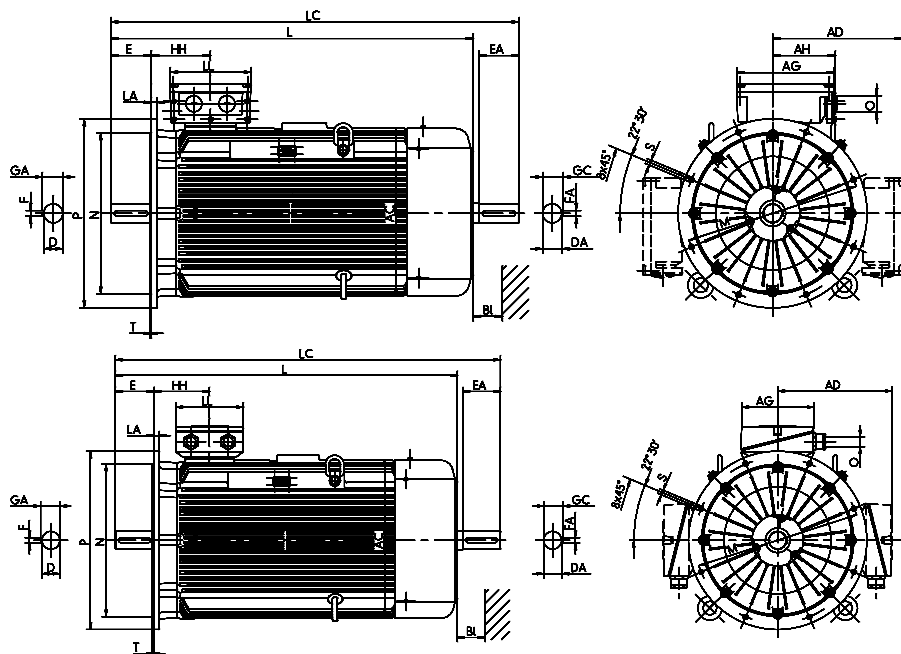

Type designation	Flange size	AC g	AD ^{*)} g1	D d	DA d1	DB ^{*)} M20	E l	EA l1	F u	FA u1	GA t	GC t1	H h	HH A	L k	LC k1	KK Type	AG x	LL z	AH -	O r	BI BI
IE2-AE1R 315 S2	FF 600	550	416	65	65	M20	140	140	18	18	69	69	315	211	1050	1218	KK 200 A	282	242	-	M63 x 1.5	55
IE2-AE1R 315 M2	FF 600	550	416	65	65	M20	140	140	18	18	69	69	315	211	1105	1273	KK 200 A	282	242	-	M63 x 1.5	55
IE2-AE1R 315 MX2	FF 600	550	416	65	65	M20	140	140	18	18	69	69	315	211	1185	1353	KK 200 A	282	242	-	M63 x 1.5	55
IE2-AE1R 315 MY2	FF 600	610	498	65	65	M20	140	140	18	18	69	69	315	230	1270	1448	KK 400 B	415	340	265	M63 x 1.5	55
IE2-AE1R 315 L2	FF 600	610	498	65	65	M20	140	140	18	18	69	69	315	230	1390	1543	KK 400 B	415	340	265	M63 x 1.5	55
IE2-AE1R 315 LX2	FF 600	610	498	65	65	M20	140	140	18	18	69	69	315	230	1510	1688	KK 400 B	415	340	265	M63 x 1.5	55
IE2-AE1R 315 S4	FF 600	550	416	80	70	M20	170	140	22	20	85	74.5	315	211	1080	1248	KK 200 A	282	242	-	M63 x 1.5	55
IE2-AE1R 315 M4	FF 600	550	416	80	70	M20	170	140	22	20	85	74.5	315	211	1135	1303	KK 200 A	282	242	-	M63 x 1.5	55
IE2-AE1R 315 MX4	FF 600	550	416	80	70	M20	170	140	22	20	85	74.5	315	211	1215	1383	KK 200 A	282	242	-	M63 x 1.5	55
IE2-AE1R 315 MY4	FF 600	610	498	80	70	M20	170	140	22	20	85	74.5	315	230	1300	1478	KK 400 B	415	340	265	M63 x 1.5	55
IE2-AE1R 315 L4	FF 600	610	498	80	70	M20	170	140	22	20	85	74.5	315	230	1420	1598	KK 400 B	415	340	265	M63 x 1.5	55
IE2-AE1R 315 LX4	FF 600	610	498	80	70	M20	170	140	22	20	85	74.5	315	230	1540	1723	KK 400 B	415	340	265	M63 x 1.5	55
IE2-AE1R 315 S6	FF 600	550	416	80	70	M20	170	140	22	20	85	74.5	315	211	1135	1303	KK 200 A	282	242	-	M63 x 1.5	55
IE2-AE1R 315 M6	FF 600	550	416	80	70	M20	170	140	22	20	85	74.5	315	211	1135	1303	KK 200 A	282	242	265	M63 x 1.5	55
IE2-AE1R 315 MX6	FF 600	610	498	80	70	M20	170	140	22	20	85	74.5	315	230	1300	1478	KK 400 B	415	340	265	M63 x 1.5	55
IE2-AE1R 315 MY6	FF 600	610	498	80	70	M20	170	140	22	20	85	74.5	315	230	1300	1478	KK 400 B	415	340	265	M63 x 1.5	55
IE2-AE1R 315 L6	FF 600	610	498	80	70	M20	170	140	22	20	85	74.5	315	230	1420	1598	KK 400 B	415	340	265	M63 x 1.5	55
IE2-AE1R 315 LX6	FF 600	610	498	80	70	M20	170	140	22	20	85	74.5	315	230	1420	1598	KK 400 B	415	340	265	M63 x 1.5	55
IE2-AE1R 315 S8	FF 600	550	416	80	70	M20	170	140	22	20	85	74.5	315	211	1135	1303	KK 200 A	282	242	-	M63 x 1.5	55
IE2-AE1R 315 M8	FF 600	550	416	80	70	M20	170	140	22	20	85	74.5	315	211	1135	1303	KK 200 A	282	242	-	M63 x 1.5	55
IE2-AE1R 315 MX8	FF 600	610	498	80	70	M20	170	140	22	20	85	74.5	315	230	1300	1478	KK 400 B	415	340	265	M63 x 1.5	55
IE2-AE1R 315 MY8	FF 600	610	498	80	70	M20	170	140	22	20	85	74.5	315	230	1300	1478	KK 400 B	415	340	265	M63 x 1.5	55
IE2-AE1R 315 L8	FF 600	610	498	80	70	M20	170	140	22	20	85	74.5	315	230	1420	1598	KK 400 B	415	340	265	M63 x 1.5	55
IE2-AE1R 315 LX8	FF 600	610	498	80	70	M20	170	140	22	20	85	74.5	315	230	1420	1598	KK 400 B	415	340	265	M63 x 1.5	55

^{*)}Centre holes to DIN 332-DS

^{**)}Terminal box left/right



For detailed information
please visit our website.

SENSE EXPERIENCE
EXPERIENCE VISION | www.vem-group.com